

*Operator's Manual*

# EA600

*Aera-Vator*





500 Venture Drive  
Orrville Oh 44667  
www.ventrac.com

View all manuals



Visit [ventrac.com/manuals](http://ventrac.com/manuals) for the latest version of this operator's manual.

A downloadable parts manual is also available.

### To the Owner Contact Information and Product Identification

If you need to contact an authorized Ventrac dealer for information on servicing your product, always provide the product model and serial numbers.

*Please fill in the following information for future reference. See the picture(s) below to find the location of the identification numbers. Record them in the spaces provided.*

Date of Purchase: \_\_\_\_\_

Dealer: \_\_\_\_\_

Dealer Address: \_\_\_\_\_  
\_\_\_\_\_

Dealer Phone Number: \_\_\_\_\_

Dealer Fax Number: \_\_\_\_\_

Model # (A): \_\_\_\_\_

Serial # (B): \_\_\_\_\_

Affix Part/Serial Number label here.

Seeder Serial # (C) \_\_\_\_\_

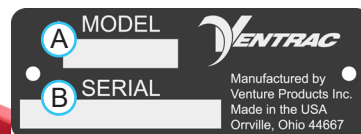

Venture Products Inc. reserves the right to make changes in design or specifications without obligation to make like changes on previously manufactured products.

# TABLE OF CONTENTS

<b>INTRODUCTION</b>	<b>PAGE 5</b>
Product Description.....	5
Why Do I Need an Operator’s Manual? .....	5
Using Your Manual .....	6
Manual Glossary .....	6
<b>SAFETY</b>	<b>PAGE 7</b>
Safety Decals .....	7
General Safety Procedures.....	9
Training Required.....	9
Requirements for Personal Protective Equipment (PPE).....	9
Operation Safety .....	9
Preventing Accidents.....	10
Keep Riders Off.....	10
Operating On Slopes.....	11
Roadway Safety .....	11
Truck Or Trailer Transport .....	11
Maintenance.....	12
Fuel Safety .....	12
Hydraulic Safety .....	13
<b>OPERATIONAL CONTROLS</b>	<b>PAGE 14</b>
Operational Control Locations.....	14
Clutch Handle (A).....	14
Shut Off Lever - Optional Seeder Kit (D).....	14
Slide Gauge Cam - Optional Seeder Kit (E).....	14
12 Volt Switch - Optional Seeder Kit (F).....	14
<b>GENERAL OPERATION</b>	<b>PAGE 15</b>
Daily Inspection.....	15
Attaching .....	15
Detaching .....	15
Operating Procedures.....	16
Transport of AERA-vator .....	16
Seeder Calibration Procedure.....	16
Seed Rate Charts.....	18
<b>SERVICE</b>	<b>PAGE 30</b>
Cleaning and General Maintenance.....	30
Cleaning of Optional Seeder .....	30
Belt Inspection.....	30
Gearbox Drive Belt Replacement.....	30
Triple Drive Belt Replacement .....	31
Triple Drive Belt Adjustment.....	31
Drive Chain Tension Inspection (Optional Seeder) .....	32
Drive Chain Tension Adjustment (Optional Seeder).....	32
Lubrication Locations .....	33

# TABLE OF CONTENTS

---

## **SERVICE (continued)**

Checking Gearbox Oil Level .....	33
Changing Gearbox Oil.....	33
Storage.....	34
Rotor Shaft Service Instructions.....	34
Rotor Shaft Removal.....	34
Rotor Shaft Disassembly.....	35
Rotor Hub Disassembly .....	35
Rotor Hub Reassembly .....	36
Rotor Shaft Reassembly .....	36
Rotor Shaft Installation.....	38
Tine Replacement .....	38
Maintenance Schedule.....	39
Maintenance Checklist.....	39

## **SPECIFICATIONS**

**PAGE 40**

Dimensions .....	40
Features .....	40

## **WARRANTY**

**PAGE 41**

# INTRODUCTION



Venture Products Inc. is pleased to provide you with your new Ventrac EA600 aera-vator! We hope that Ventrac equipment will provide you with a ONE Tractor Solution.

Listed below are just some of the items that can provide you *versatility* as you use your aera-vator. Please visit our website, or contact your authorized Ventrac dealer for a complete list of items available for your new EA600 aera-vator.

Accessories	Item Description	Part Number
	Rear Roller Kit	70.8014
	Seeder Kit*	70.8015

\*Power unit must be equipped with front 12 volt switch and plug kit.

## Product Description

The Ventrac EA600 AERA-vator is designed to stir and loosen the soil beneath the sod without destroying the turf. The AERA-vator creates a core hole without bringing a core plug to the surface, leaving the turf ready for use immediately after treatment. Eight holes are created each foot (86 holes / square meter) (serial # 1001-1139 = 6 holes / square foot - 65 holes / square meter) and hole size is regulated by drive speed -- the slower the drive speed, the larger the hole.

The AERA-vator works best in dry un-irrigated ground, leaving a core hole while fracturing the sub soil. For heavily compacted areas or hard clay soil, eight 42 pound (19 kg) Ventrac weights may be mounted on the main frame. Weights cannot be used if the seeder attachment is installed.

The optional seeder mounts to the frame of the AERA-vator and is designed for the sole purpose of seed application. The metering mechanism is precision tooled to assure you of uniform application from each hopper opening. Each of the mechanism's features is designed for long life and accuracy. The stainless steel hopper bottom and slide are micro-precision mated for uniform application at any setting. The diamond shaped openings allow no particle hang up from very small to large settings.

## Why Do I Need an Operator's Manual?

This manual has been created to help you gain the important knowledge of what is needed to safely operate, maintain, and service your machine. It is divided into sections for convenient reference of the appropriate section.

You must read and understand the operator's manual for each piece of Ventrac equipment you own. Reading the operator's manual will help you become familiar with each specific piece of equipment. Understanding the operator's manual will help you, as well as others, avoid personal injury and/or damage to the equipment. Keep this manual with the machine at all times. The manual should remain with the machine even if it is sold. If this manual becomes damaged or unreadable, it should be replaced immediately. Contact your local Ventrac dealer for a replacement.

When using a Ventrac attachment, be sure to read and follow the safety and operating instructions of both the power unit and the attachment being used to ensure the safest operation possible.

The information in this manual provides the operator with the safest procedures to operate the machine while getting the maximum use out of the unit. Failure to follow the safety precautions listed in this manual may result in personal injury and/or damage to the equipment.

# INTRODUCTION

---

## Using Your Manual

Throughout this manual, you will encounter special messages and symbols that identify potential safety concerns to help you as well as others avoid personal injury or damage to the equipment.

### SYMBOL DEFINITIONS



#### **ATTENTION**

This symbol identifies potential health and safety hazards. It marks safety precautions. Your safety and the safety of others is involved.

There are three signal words that describe the level of safety concern: Danger, Warning, and Caution. Safety should always be the #1 priority when working on or operating equipment. Accidents are more likely to occur when proper operating procedures are not followed or inexperienced operators are involved.

Note: Right-Hand and Left-Hand orientations may be referred to at different places throughout this manual. Right-Hand and Left-Hand is determined as if sitting on the power unit seat facing forward.

### SIGNAL WORD DEFINITIONS

#### **⚠ DANGER**

Indicates an imminently hazardous situation which, if not avoided, will result in death or serious injury. This signal word is limited to the most extreme cases.

#### **⚠ WARNING**

Indicates a potentially hazardous situation which, if not avoided, could result in death or serious injury.

#### **⚠ CAUTION**

Indicates a potentially hazardous situation which, if not avoided, may result in minor or moderate injury and/or property damage. It may also be used to alert against unsafe practices.

## Manual Glossary

**Power Unit** A Ventrac tractor or other Ventrac engine powered device that may be operated by itself or with an attachment or accessory.

**Attachment** A piece of Ventrac equipment that requires a Power Unit for operation.

**Accessory** A device that attaches to a Power Unit or Attachment to extend its capabilities.

**Machine** Describes any "Attachment" or "Accessory" that is used in conjunction with a power unit.

# SAFETY

## Safety Decals

The following safety decals must be maintained on your EA600 AERA-vator and optional seeder kit. Keep all safety decals legible. Remove all grease, dirt, and debris from safety decals and instructional labels. If any decals are faded, illegible, or missing, contact your dealer promptly for replacements. When new components are installed, be sure that current safety decals are affixed to the replacement components.

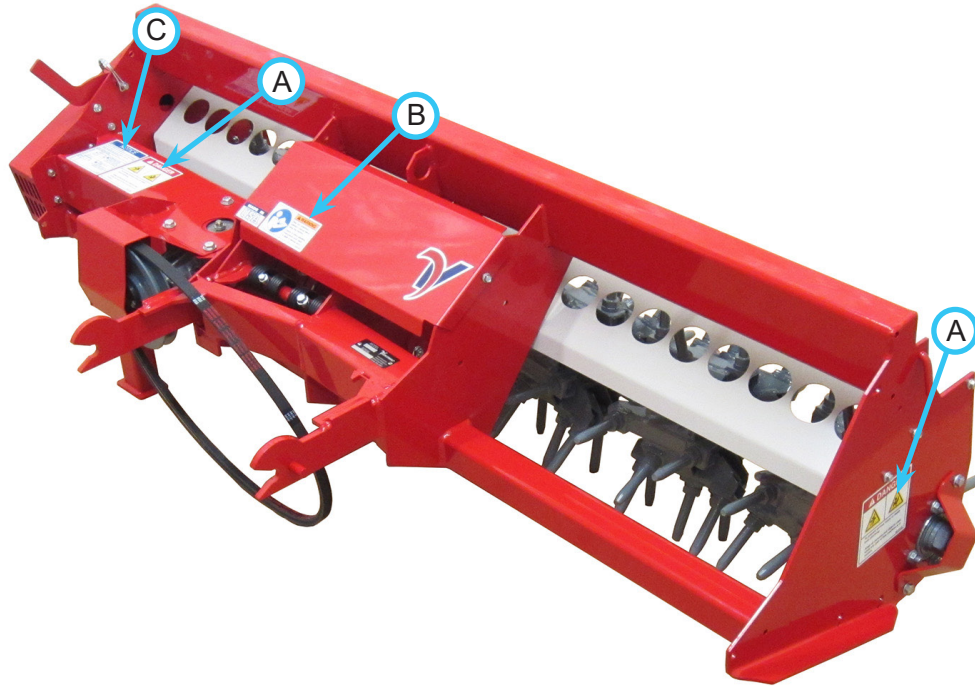



# SAFETY

**A**

**⚠ DANGER**





**To prevent serious injury or death from pinching:**

- Keep all persons and objects clear while any part of this machine is in motion.

00.0102

**B**



**⚠ WARNING**

**Read and understand operator's manual before using this machine.**

**Failure to follow operating instructions could result in death or serious injury.**

PART NO. 00.0217

**C**

**NOTICE**

**When operating the Aera-Vator:**

- The tractor's Weight Transfer System **MUST** be completely disengaged!
- The tractor's primary S.D.L.A. Control **MUST** be in the "FLOAT" position!
- Weights may be added to the Aera-Vator crossbar for deeper tine penetration. Do **NOT** apply hitch down pressure.

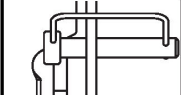
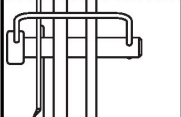

Failure to disengage the Weight Transfer and/or operate in "FLOAT" may result in damage to the machine.

Aera-Vator Drive Clutch		<b>Operating Position:</b> Clutch Handle must be released for operation. Store lock-out pin in this position when operating.
		<b>Clutch Lock-Out Position:</b> Clutch Handle <b>MUST</b> be locked in this position for attaching to the tractor.

00.0205

**D**

**⚠ WARNING**

**MOVING PART HAZARD**

To prevent serious injury or death from moving parts:

- Close and secure guards and shields before starting.
- Keep hand, feet, hair and clothing away from moving parts.
- Disconnect and lockout power source before adjusting or servicing.
- Do not stand or climb on machine when operating.

SW404

Decal	Description	Part Number	Quantity
A	Danger, Pinching Hazard	00.0102	2
B	Warning, Rear Owner's Manual	00.0217	1
C	Notice, Clutch Drive Release Pin	00.0205	1
D	Warning, Moving Part Hazard (optional seeder kit)	00.0101	1



# SAFETY



## General Safety Procedures for Ventrac Power Units, Attachments, & Accessories



### Training Required

- The owner of this machine is solely responsible for properly training the operators.
- The owner/operator is solely responsible for the operation of this machine and prevention of accidents or injuries occurring to him/herself, other people, or property.
- Do not allow operation or service by children or untrained personnel. Local regulations may restrict the age of the operator.
- Before operating this machine, read the operator's manual and understand its contents.
- If the operator of the machine cannot understand this manual, then it is the responsibility of this machine's owner to fully explain the material within this manual to the operator.
- Learn and understand the use of all controls.
- Know how to stop the power unit and all attachments quickly in the event of an emergency.



### Requirements for Personal Protective Equipment (PPE)

The owner is responsible for ensuring that all operators use the proper PPE while operating the machine. Whenever you use the machine, use the following PPE:



- Certified eye protection and hearing protection.
- Closed toe, slip resistant footwear.
- Long pants.
- A dust mask for dusty conditions.

### Operation Safety

- Inspect machine before operation. Repair or replace any damaged, worn, or missing parts. Be sure guards and shields are in proper working condition and are secured in place. Make all necessary adjustments before operating machine.
- Some pictures in this manual may show shields or covers opened or removed in order to clearly illustrate any instructions. Under no circumstance should the machine be operated without these devices in place.
- Alterations or modifications to this machine can reduce safety and could cause damage to the machine. Do not alter safety devices or operate with shields or covers removed.
- Before each use, verify that all controls function properly and inspect all safety devices. Do not operate if controls or safety devices are not in proper working condition.
- Check parking brake function before operating. Repair or adjust parking brake if necessary.
- Observe and follow all safety decals.
- All controls are to be operated from the operator's station only.
- Always wear a seat belt if the machine has a roll cage/bar installed and in upright position.
- Ensure the attachment or accessory is locked or fastened securely to the power unit before operating.
- Ensure that all bystanders are clear of the power unit and attachment before operating. Stop machine if someone enters your work area.
- Always be alert to what is happening around you, but do not lose focus on the task you are performing. Always look in the direction the machine is moving.
- Look behind and down before backing up to be sure of a clear path.
- If you hit an object, stop and inspect the machine. Make all necessary repairs before operating machine again.
- Stop operation immediately at any sign of equipment failure. An unusual noise can be a warning of equipment failure or a sign that maintenance is required. Make all necessary repairs before operating machine again.
- If equipped with a high/low range feature, never shift between high and low range while on a slope. Always move the machine to level ground and engage the parking brake before shifting range.

# SAFETY



## General Safety Procedures for Ventrac Power Units, Attachments, & Accessories



### Operation Safety (continued)

- Do not leave machine unattended while it is running.
- Always park the machine on level ground.
- Always shut off engine when connecting attachment drive belt to the power unit.
- Never leave the operator's station without lowering the attachment to the ground, setting the parking brake, shutting off the engine, and removing the ignition key. Make sure all moving parts have come to a complete stop before dismounting.
- Never leave equipment unattended without lowering the attachment to the ground, setting the parking brake, shutting off the engine, and removing the ignition key.
- Only operate in well-lit conditions.
- Do not operate when there is a risk of lightning.
- Never direct the discharge of any attachment in the direction of people, buildings, animals, vehicles, or other objects of value.
- Never discharge material against a wall or obstruction. Material may ricochet back towards the operator.
- Use extra caution when approaching blind corners, shrubs, trees, or other objects that may obscure vision.
- Do not run the engine in a building without adequate ventilation.
- Do not touch the engine or the muffler while the engine is running or immediately after stopping the engine. These areas may be hot enough to cause a burn.
- Do not change the engine governor settings or over-speed the engine. Operating engine at excessive speed may increase the hazard of personal injury.
- To reduce the hazard of fire, keep the battery compartment, engine, and muffler areas free of grass, leaves, excessive grease, and other flammable materials.
- Secure long hair and loose clothing. Do not wear jewelry.

### Preventing Accidents



- Clear working area of objects that might be hit or thrown from machine.
- Keep people and pets out of working area.
- Know the work area well before operation. Do not operate where traction or stability is questionable.
- Reduce speed when you are operating over rough ground.
- Equipment can cause serious injury and/or death when improperly used. Before operating, know and understand the operation and safety of the power unit and the attachment being used.

- Do not operate machine if you are not in good physical and mental health, if you will be distracted by personal devices, or are under the influence of any substance which might impair decision, dexterity, or judgment.
- Children are attracted to machine activity. Be aware of children and do not allow them in the working area. Turn off the machine if a child enters the work area.

### Keep Riders Off

- Only allow the operator on the power unit. Keep riders off.
- Never allow riders on any attachment or accessory.

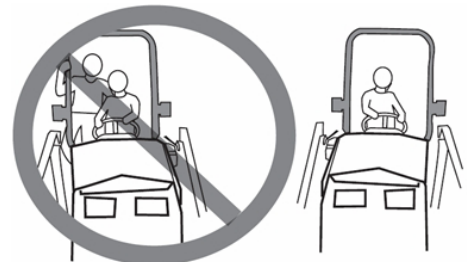

# SAFETY



## General Safety Procedures for Ventrac Power Units, Attachments, & Accessories



### Operating On Slopes

- Slopes can cause loss-of-control and tip-over accidents, which can result in severe injury or death. Be familiar with the emergency parking brake, along with the power unit controls and their functions.
- If power unit is equipped with a fold down roll bar, it must be locked in the upright position when operating on any slope.
- Use low range (if equipped) when operating on slopes greater than 15 degrees.
- Do not stop or start suddenly when operating on slopes.
- Never shift between high and low range while on a slope. Always move the power unit to level ground and engage the parking brake before shifting range or placing the power unit in neutral.
- Variables such as wet surface and loose ground will reduce the degree of safety. Do not drive where machine could lose traction or tip over.
- Keep alert for hidden hazards in the terrain.
- Stay away from drop-offs, ditches, and embankments.
- Sharp turns should be avoided when operating on slopes.
- Pulling loads on hills decreases safety. It is the responsibility of the owner/operator to determine loads that can safely be controlled on slopes.
- Transport machine with attachment lowered or close to the ground to improve stability.
- While operating on slopes, drive in an up and down direction when possible. If turning is necessary while driving across slopes, reduce speed and turn slowly in the downhill direction.
- Ensure a sufficient supply of fuel for continuous operation. A minimum of one-half tank of fuel is recommended.

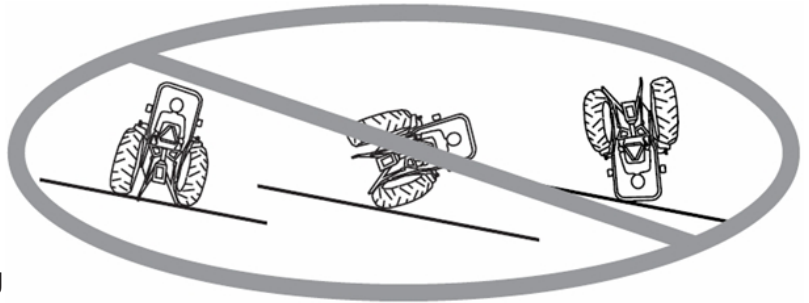

### Roadway Safety

- Operate with safety lights when operating on or near roadways.
- Obey all state and local laws concerning operation on roadways.
- Slow down and be careful of traffic when operating near or crossing roadways. Stop before crossing roads or sidewalks. Use care when approaching areas or objects that may obscure vision.
- If there is doubt of safety conditions, discontinue machine operation until a time when operation can be performed safely.
- When operating near or on roadways, have a Slow Moving Vehicle Emblem clearly displayed.

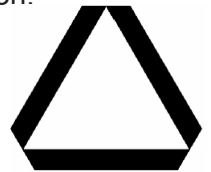

### Truck Or Trailer Transport

- Use care when loading or unloading machine into a truck or trailer.
- Use full width ramps for loading machine into a truck or trailer.
- The parking brake is not sufficient to lock the machine during transport. Always secure the power unit and/or attachment to the transporting vehicle securely using straps, chains, cable, or ropes. Both front and rear straps should be directed down and outward from the machine.
- Shut off fuel supply to power unit during transport on truck or trailer.
- If equipped, turn the battery disconnect switch to the Off position to shut off electrical power.

# SAFETY



## General Safety Procedures for Ventrac Power Units, Attachments, & Accessories



### Maintenance

- Keep all safety decals legible. Remove all grease, dirt, and debris from safety decals and instructional labels.
- If any decals are faded, illegible, or missing, contact your dealer promptly for replacements.
- When new components are installed, be sure that current safety decals are affixed to the replacement components.
- If any component requires replacement, use only original Ventrac replacement parts.
- Always turn the battery disconnect to the Off position or disconnect the battery before performing any repairs. Disconnect the negative terminal first and the positive terminal last. Reconnect the positive terminal first and the negative terminal last.
- Keep all bolts, nuts, screws, and other fasteners properly tightened.
- Always lower the attachment to the ground, engage parking brake, shut off engine, and remove the ignition key. Make sure all moving parts have come to a complete stop before cleaning, inspection, adjusting or repairing.
- If the power unit, attachment, or accessory requires repairs or adjustments not instructed in the operator's manual, the power unit, attachment, or accessory must be taken to an authorized Ventrac dealer for service.
- Never perform maintenance on the power unit and/or attachment if someone is in the operator's station.
- Always use protective glasses when handling the battery.
- Check all fuel lines for tightness and wear on a regular basis. Tighten or repair them as needed.
- To reduce the hazard of fire, keep the battery compartment, engine, and muffler areas free of grass, leaves, and excessive grease.
- Do not touch the engine, the muffler, or other exhaust components while the engine is running or immediately after stopping the engine. These areas may be hot enough to cause a burn.
- Allow the engine to cool before storing and do not store near an open flame.
- Do not change the engine governor settings or over-speed the engine. Operating engine at excessive speed may increase the hazard of personal injury.
- Springs may contain stored energy. Use caution when disengaging or removing springs and/or spring loaded components.
- An obstruction or blockage in a drive system or moving/rotating parts may cause a buildup of stored energy. When the obstruction or blockage is removed, the drive system or moving/rotating parts may move suddenly. Do not attempt to remove an obstruction or blockage with your hands. Keep hands, feet, and clothing away from all power-driven parts.

### Fuel Safety



- To avoid personal injury or property damage, use extreme care in handling gasoline. Gasoline is extremely flammable and the vapors are explosive.
- Do not refuel machine while smoking or at a location near flames or sparks.
- Always refuel the machine outdoors.
- Do not store machine or fuel container indoors where fumes or fuel can reach an open flame, spark, or pilot light.
- Only store fuel in an approved container. Keep out of reach of children.
- Never fill containers inside a vehicle or on a truck or trailer bed with a plastic liner. Always place containers on the ground away from your vehicle before filling.
- Remove machine from the truck or trailer and refuel it on the ground. If this is not possible, refuel the machine using a portable container, rather than from a fuel dispenser nozzle.
- Never remove fuel cap or add fuel with the engine running. Allow engine to cool before refueling.
- Never remove fuel cap while on a slope. Only remove when parked on a level surface.
- Replace all fuel tank and container caps securely.
- Do not overfill fuel tank. Only fill to bottom of fuel neck, do not fill fuel neck full. Overfilling of fuel tank could

# SAFETY



## General Safety Procedures for Ventrac Power Units, Attachments, & Accessories



### Fuel Safety (continued)

- result in engine flooding, fuel leakage from the tank, and/or damage to the emissions control system.
- If fuel is spilled, do not attempt to start the engine. Move the power unit away from the fuel spill and avoid creating any source of ignition until fuel vapors have dissipated.
- If the fuel tank must be drained, it should be drained outdoors into an approved container.
- Check all fuel lines for tightness and wear on a regular basis. Tighten or repair them as needed.
- The fuel system is equipped with a shut-off valve. Shut off the fuel when transporting the machine to and from the job, when parking the machine indoors, or when servicing the fuel system.

### Hydraulic Safety

- Make sure all hydraulic connections are tight and all hydraulic hoses and tubes are in good condition. Repair any leaks and replace any damaged or deteriorated hoses or tubes before starting the machine.
- Hydraulic leaks can occur under high pressure. Hydraulic leaks require special care and attention.
- Use a piece of cardboard and a magnifying glass to locate suspected hydraulic leaks.



- Keep body and hands away from pinhole leaks or nozzles that eject high pressure hydraulic fluid. Hydraulic fluid escaping under high pressure can penetrate the skin causing serious injury, leading to severe complications and/or secondary infections if left untreated. If hydraulic fluid is injected into the skin, seek immediate medical attention no matter how minor the injury appears.

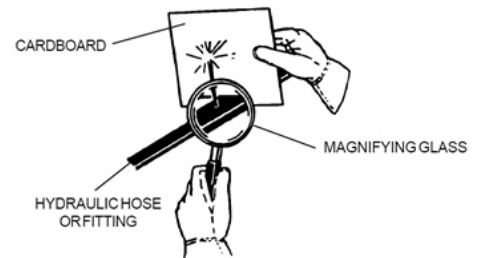

- Hydraulic system may contain stored energy. Before performing maintenance or repairs on the hydraulic system, remove attachments, engage parking brake, disengage weight transfer system (if equipped), shut off engine, and remove ignition key. To relieve pressure on the auxiliary hydraulic system, shut off the power unit engine and move the hydraulic control lever left and right before disconnecting the auxiliary hydraulic quick couplers.



# OPERATIONAL CONTROLS

## Operational Control Locations

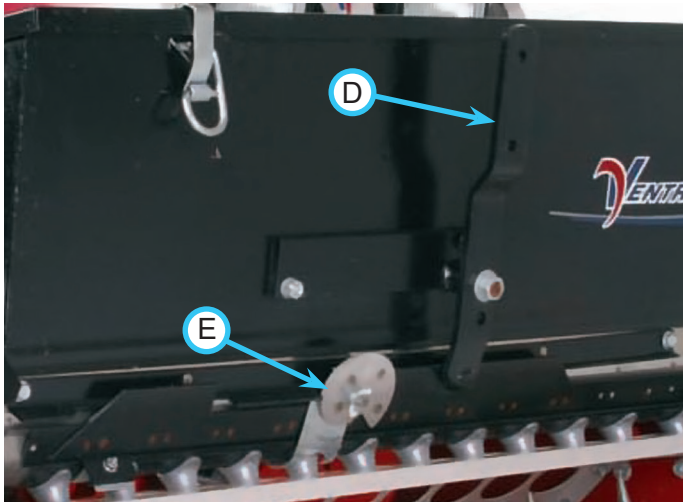
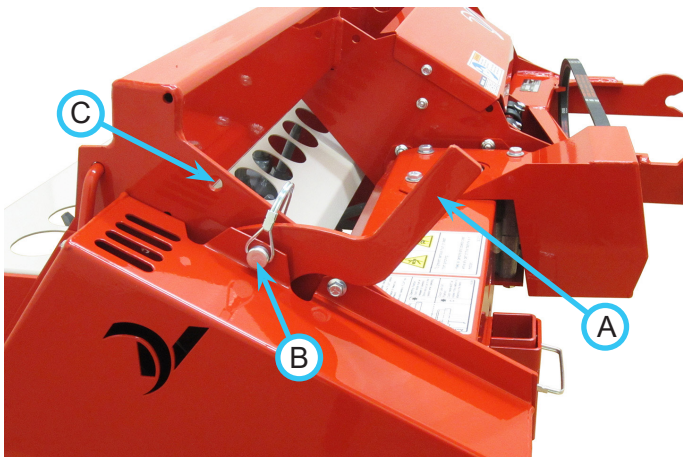

## Shut Off Lever - Optional Seeder Kit (D)

The shut off lever opens and closes the slide to control the product flow. When facing the front of the seeder, move the lever to the left until the slide stop contacts the hopper stop to close the bottom hopper openings. Move the lever to the right to open the bottom hopper openings.

## Slide Gauge Cam - Optional Seeder Kit (E)

When the shut off lever is moved to the right, the slide opens until the slide gauge cam contacts the hopper stop, thereby regulating the application rate of the product. The bottom hopper openings increase as the cam is rotated from 0 to 80. When the slide gauge cam is set, it allows the slide to be closed and opened while maintaining the application rate.

## 12 Volt Switch - Optional Seeder Kit (F)

The 12 volt switch on the power unit controls power to the motor. When the motor is switched on, it turns the rotor to assure a constant flow of product to the bottom hopper openings. When the motor is switched off, the rotor stops and restricts the flow of the product, allowing only the particles in the rotor segment(s) over the bottom hopper openings to flow out.

## Clutch Handle (A)

After attaching to the power unit, remove the lockout pin (B) to release the clutch handle (A) and allow the clutch system to operate. Place the pin in the upper frame hole (C) for storage during operation.

Before detaching from the power unit, place the clutch handle in the lockout position and secure with the lockout pin. This positions the clutch release arm for reattachment. If the clutch handle is not secured in the lockout position prior to detachment, the handle can be manually moved to the lockout position and secured with the lockout pin.

# GENERAL OPERATION

## Daily Inspection

### **⚠ WARNING**

Always set the parking brake, shut off power unit engine, remove the ignition key, and ensure all moving parts have come to a complete stop before inspecting components, or attempting any repair or adjustment.

1. Park machine on a level surface, with the engine shut off and all fluids cold.
2. Perform a visual inspection of both the power unit and the AERA-vator. Look for loose or missing hardware, damaged components, or signs of wear.
3. If equipped with optional seeder, inspect the seeder for loose or missing hardware and damaged or worn components.
4. Inspect the drive belts. Belts should be in good condition. Service as required.
5. Inspect the AERA-vator for broken or damaged tines and replace as needed.
6. Refer to the power unit operator's manual. Check the power unit's engine oil, hydraulic oil, cooling system, tire pressure, and fuel level. Add fluid or service as required.
7. Test the power unit's operator safety interlock system\*.

## Attaching

1. Check to ensure the AERA-vator's clutch handle is in the lockout position before attempting to attach to the power unit.
2. Disengage the power unit's weight transfer system\* (if equipped).
3. Drive the power unit slowly forward into the hitch arms of the AERA-vator. Align the lift arms of the power unit with the AERA-vator hitch arms by raising or lowering the front hitch and complete the engagement.
4. Once completely engaged, close the front hitch locking lever.\*
5. Engage the parking brake\* and shut off the engine.
6. Place the attachment belt onto the PTO drive pulley on the power unit. Ensure the belt is properly seated in each pulley.
7. Engage the PTO tension spring.
8. If equipped with an optional seeder kit, connect the electric plug.
9. Raise the AERA-vator and move the jack stand (A) up to the operating position.
10. Remove the lockout pin from the clutch handle and place it in the upper frame hole for storage during operation.

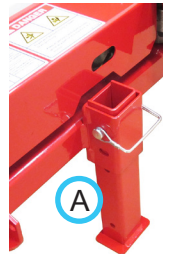

## Detaching

1. Park the power unit on a level surface, engage the parking brake\* and shut off power unit engine.
2. Install the lockout pin through the clutch handle and AERA-vator main frame to secure the clutch handle in the lockout position.
3. Lower the aera-vator to the ground and move the jack stand down to the storage position.
4. Disengage the PTO tension spring.
5. Remove the attachment belt from the PTO drive pulley of the power unit.
6. Disengage the front hitch locking lever.\*
7. If equipped with an optional seeder kit, disconnect the electric plug.
8. Restart power unit and slowly back away from the AERA-vator. A side to side movement of the steering wheel may aid in disengagement.

\* Refer to power unit operator's manual for operation of power unit controls.



# GENERAL OPERATION

## Operating Procedures



### Attention

The power unit's weight transfer system (if equipped) must be disengaged in order for the AERA-vator's clutch drive to function properly. Failure to disengage the weight transfer may result in premature failure of clutch drive belts.

Prior to operation, perform daily inspection and disengage the power unit's weight transfer system (if equipped).

If applicable, confirm the seeder is properly calibrated.



### Attention

Road travel with product in the hopper can cause compaction of some materials, making it difficult for the motor to start. It is recommended that you load the hopper at the location where you will be applying the product.

Load the seeder hopper with product to be applied.

With the power unit's engine running between 2,000 and 2,500 RPM, engage the PTO switch. Adjust the throttle until the engine is running at approximately 3,200 RPM.

Drive forward slowly while lowering the AERA-vator to the ground and engaging the 12 volt switch to start the seeder (if applicable). Place the power unit's primary SDLA lever into the float position by pushing it to the right until the detent engages. As the AERA-vator contacts the ground, the clutch will engage and tine action will begin.

The ground speed of the power unit determines the aggressiveness of the tine action. Driving slow will give the most action for loosening soil. When using the seeder, operate at the speed used for seeder calibration in order to maintain the desired application rate.

Do not make sharp turns with the tines in the ground.

When completing a pass, turn off the seeder and begin to raise the AERA-vator before stopping the power unit's forward speed. When the AERA-vator is raised, the clutch will disengage and stop the tine action.

When using the AERA-vator on a sports field or golf course, it is advisable to use the optional rear roller to level out any bumps or unevenness.

In heavily compacted or hard soils, the AERA-vator may need additional weight to fully penetrate the ground. The main frame is built to allow the installation of up to eight Ventrac weights. Maximum weight capacity of the AERA-vator is 340 pounds (154 kg).

NOTE: weights cannot be installed on the main frame if the seeder attachment kit is installed.

When the job is complete, disengage the power unit's PTO switch. Disengage the 12 volt switch to turn off the seeder and close the seeder's shut off lever (if applicable).

Empty any remaining product from the seeder's hopper by discharging onto a tarp.

## Transport of AERA-vator

Transport the AERA-vator with the power unit front hitch fully raised. Travel slowly when transporting over undulating and rough surfaces to maintain control of the power unit and to reduce shock to the power unit and AERA-vator. Always disengage the power unit PTO before transporting the AERA-vator.

If equipped with optional seeder, turn off the seeder motor before transporting the AERA-vator and seeder.

## Seeder Calibration Procedure



### Attention

It is the responsibility of the operator to ensure that each material is properly calibrated in the applicator prior to application in the field. Failure to do so may cause under application with poor results, or over application which can result in poor start or excessive seed rates.

The seed rate charts are to serve only as guides in initial setting, as seed are supplied and run under factory laboratory conditions.

Each product flows differently, requiring calibration for each product. Variations in formulations, particle size, humidity, temperature, and age of product may affect application rates.

A few minutes invested before application results in the most effective use of your seed and makes the wisest use of your turf management efforts.

**Remember** flow rates can change because:

- mixes vary within the same brand or between brands.
- mixes vary between batches or years of production.
- atmospheric conditions alter the flow rate.
- poor applicator maintenance alters the flow rate.
- incorrect control/sprocket installation alters the flow rate.
- slide closure, rate gauge, or setting has been moved from the correct position.
- miscalculation of flow rate.

# GENERAL OPERATION

To calibrate you will need to catch the material for weighing. Do not apply directly to the soil. Plan ahead to have the necessary items with you for quick calibration (e.g. a scale, recovery bags or tarpaulin, calibration tubes, and stopwatch/timer).

## CAUTION

Do not leave the rotor switched on with the slide closed for long periods of time. This causes undue wear of the rotor vanes and could cause damage to the product (seed) in the hopper.

Calibration takes minimal time if you are prepared to do it correctly.

1. Determine the desired application rate based on pounds per 1,000 square feet. Divide pounds per acre by 43.6 to convert to pounds per 1,000 square feet.
2. Determine the desired power unit ground speed for application.
3. Use the following chart to determine the amount of time required to cover 1,000 square feet at the desired speed. For the 405VP seeder, this would be the time to travel a distance of 200 feet.

Speed (MPH)	Time required to travel 200 feet
1/2	4 minutes & 33 seconds
1	2 minutes & 16 seconds
1-1/2	1 minute & 31 seconds
2	1 minute & 8 seconds
2-1/2	55 seconds
3	45 seconds
3-1/2	39 seconds
4	34 seconds
4-1/2	30 seconds
5	27 seconds
5-1/2	25 seconds
6	23 seconds

4. Spread a tarp to catch the product and position beneath the AERA-vator and seeder. Turn on the seeder and open the slide until a uniform flow is attained through the tubes. Slowly close the slide until the flow is estimated to be the desired application rate. Set the slide gauge cam and close the slide. Turn off the seeder and remove product from the tarp.

## CAUTION

Do not leave the seeder motor running for long periods of time while the slide is closed. This causes premature wear of the rotor vanes and could cause damage to the product (seed) in the hopper.

5. Turn on the seeder and open the shut off lever until the gauge cam contacts the hopper stop. Catch the product for the exact time required to travel 200 feet and close the shut off lever. Weigh the product caught in the tarp and compare it to the desired application rate. Adjust the gauge cam to attain the desired application rate.



## Attention

To maintain the desired application rate, always operate the power unit at the established speed.

# GENERAL OPERATION

## Seed Rate Charts

### Athletic Mix 50/blu 50/rye Futura Pickseed

Cam Gauge Settings	Rate in Pounds Per 1,000 Square Feet									
	@ 1.0 Mph	@ 2.0 Mph	@ 3.0 Mph	@ 4.0 Mph	@ 5.0 Mph	@ 6.0 Mph	@ 7.0 Mph	@ 8.0 Mph	@ 9.0 Mph	@ 10.0 Mph
20	0.3	0.1	0.1	0.1	0.1	0.0	0.0	0.0	0.0	0.0
21	0.3	0.2	0.1	0.1	0.1	0.1	0.0	0.0	0.0	0.0
22	0.4	0.2	0.1	0.1	0.1	0.1	0.1	0.0	0.0	0.0
23	0.4	0.2	0.1	0.1	0.1	0.1	0.1	0.1	0.0	0.0
24	0.5	0.3	0.2	0.1	0.1	0.1	0.1	0.1	0.1	0.1
25	0.6	0.3	0.2	0.1	0.1	0.1	0.1	0.1	0.1	0.1
26	0.7	0.3	0.2	0.2	0.1	0.1	0.1	0.1	0.1	0.1
27	0.8	0.4	0.3	0.2	0.2	0.1	0.1	0.1	0.1	0.1
28	0.9	0.4	0.3	0.2	0.2	0.1	0.1	0.1	0.1	0.1
29	1.0	0.5	0.3	0.2	0.2	0.2	0.1	0.1	0.1	0.1
30	1.1	0.5	0.4	0.3	0.2	0.2	0.2	0.1	0.1	0.1
31	1.3	0.7	0.4	0.3	0.3	0.2	0.2	0.2	0.1	0.1
32	1.5	0.8	0.5	0.4	0.3	0.3	0.2	0.2	0.2	0.2
33	1.8	0.9	0.6	0.5	0.4	0.3	0.3	0.2	0.2	0.2
34	2.0	1.0	0.7	0.5	0.4	0.3	0.3	0.3	0.2	0.2
35	2.3	1.1	0.8	0.6	0.5	0.4	0.3	0.3	0.3	0.2
36	2.7	1.3	0.9	0.7	0.5	0.4	0.4	0.3	0.3	0.3
37	3.0	1.5	1.0	0.8	0.6	0.5	0.4	0.4	0.3	0.3
38	3.4	1.7	1.1	0.9	0.7	0.6	0.5	0.4	0.4	0.3
39	3.8	1.9	1.3	0.9	0.8	0.6	0.5	0.5	0.4	0.4
40	4.2	2.1	1.4	1.0	0.8	0.7	0.6	0.5	0.5	0.4
41	4.6	2.3	1.5	1.2	0.9	0.8	0.7	0.5	0.5	0.5
42	5.1	2.6	1.7	1.3	1.0	0.9	0.7	0.6	0.6	0.5
43	5.6	2.8	1.9	1.4	1.1	0.9	0.8	0.7	0.6	0.6
44	6.1	3.0	2.0	1.5	1.2	1.0	0.9	0.8	0.7	0.6
45	6.5	3.3	2.2	1.6	1.3	1.1	0.9	0.8	0.7	0.7
46	7.0	3.5	2.3	1.8	1.4	1.2	1.0	0.9	0.8	0.7
47	7.6	3.8	2.5	1.9	1.5	1.3	1.1	0.9	0.8	0.8
48	8.1	4.0	2.7	2.0	1.6	1.3	1.2	1.0	0.9	0.8
49	8.6	4.3	2.9	2.1	1.7	1.4	1.2	1.1	1.0	0.9
50	9.1	4.6	3.0	2.3	1.8	1.5	1.3	1.1	1.0	0.9
51	9.7	4.8	3.2	2.4	1.9	1.6	1.4	1.2	1.1	1.0
52	10.3	5.1	3.4	2.6	2.1	1.7	1.5	1.3	1.1	1.0
53	10.9	5.4	3.5	2.7	2.2	1.8	1.6	1.4	1.2	1.1
54	11.5	5.7	3.8	2.9	2.3	1.9	1.6	1.4	1.3	1.1
55	12.0	6.0	4.0	3.0	2.4	2.0	1.7	1.5	1.3	1.2
56	12.8	6.4	4.3	3.2	2.6	2.1	1.8	1.6	1.4	1.3
57	13.6	6.8	4.5	3.4	2.7	2.3	1.9	1.7	1.5	1.4
58	14.4	7.2	4.8	3.6	2.9	2.4	2.1	1.8	1.6	1.4
59	15.2	7.6	5.1	3.8	3.0	2.5	2.2	1.9	1.7	1.5
60	16.0	8.0	5.3	4.0	3.2	2.7	2.3	2.0	1.8	1.6
61	16.8	8.4	5.6	4.2	3.4	2.8	2.4	2.1	1.9	1.7
62	17.7	8.8	5.9	4.4	3.5	2.9	2.5	2.2	2.0	1.8
63	18.5	9.3	6.2	4.6	3.7	3.1	2.6	2.3	2.1	1.9
64	19.4	9.7	6.5	4.9	3.9	3.2	2.8	2.4	2.2	1.9
65	20.3	10.1	6.8	5.1	4.1	3.4	2.9	2.5	2.3	2.0
66	21.0	10.5	7.0	5.3	4.2	3.5	3.0	2.6	2.3	2.1
67	21.8	10.9	7.3	5.5	4.4	3.6	3.1	2.7	2.4	2.2
68	22.6	11.3	7.5	5.6	4.5	3.8	3.2	2.8	2.5	2.3
69	23.4	11.7	7.8	5.8	4.7	3.9	3.3	2.9	2.6	2.3
70	24.1	12.1	8.0	6.0	4.8	4.0	3.4	3.0	2.7	2.4
71	24.5	12.2	8.2	6.1	4.9	4.1	3.5	3.1	2.7	2.4
72	24.8	12.4	8.3	6.2	5.0	4.1	3.5	3.1	2.8	2.5
73	25.2	12.6	8.4	6.3	5.0	4.2	3.6	3.1	2.8	2.5
74	25.5	12.8	8.5	6.4	5.1	4.3	3.6	3.2	2.8	2.6
75	25.9	12.9	8.6	6.5	5.2	4.3	3.7	3.2	2.9	2.6
76	26.0	13.0	8.7	6.5	5.2	4.3	3.7	3.2	2.9	2.6
77	26.1	13.1	8.7	6.5	5.2	4.4	3.7	3.3	2.9	2.6
78	26.3	13.1	8.8	6.6	5.3	4.4	3.8	3.3	2.9	2.6
79	26.4	13.2	8.8	6.6	5.3	4.4	3.8	3.3	2.9	2.6
80	26.5	13.3	8.8	6.6	5.3	4.4	3.8	3.3	2.9	2.7

# GENERAL OPERATION

## Athletic Mix 50/blu 50/rye Futura Pickseed

Cam Gauge Settings	Rate in Pounds Per Acre									
	@ 1.0 Mph	@ 2.0 Mph	@ 3.0 Mph	@ 4.0 Mph	@ 5.0 Mph	@ 6.0 Mph	@ 7.0 Mph	@ 8.0 Mph	@ 9.0 Mph	@ 10.0 Mph
20	13.1	6.5	4.4	3.3	2.6	2.2	1.9	1.6	1.5	1.3
21	13.1	6.5	4.4	3.3	2.6	2.2	1.9	1.6	1.5	1.3
22	17.4	8.7	5.8	4.4	3.5	2.9	2.5	2.2	1.9	1.7
23	17.4	8.7	5.8	4.4	3.5	2.9	2.5	2.2	1.9	1.7
24	21.8	10.9	7.3	5.4	4.4	3.6	3.1	2.7	2.4	2.2
25	26.1	13.1	8.7	6.5	5.2	4.4	3.7	3.3	2.9	2.6
26	30.5	15.2	10.2	7.6	6.1	5.1	4.4	3.8	3.4	3.0
27	34.8	17.4	11.6	8.7	7.0	5.8	5.0	4.4	3.9	3.5
28	39.2	19.6	13.1	9.8	7.8	6.5	5.6	4.9	4.4	3.9
29	43.6	21.8	14.5	10.9	8.7	7.3	6.2	5.4	4.8	4.4
30	47.9	24.0	16.0	12.0	9.6	8.0	6.8	6.0	5.3	4.8
31	56.6	28.3	18.9	14.2	11.3	9.4	8.1	7.1	6.3	5.7
32	69.7	34.8	23.2	17.4	13.9	11.6	10.0	8.7	7.7	7.0
33	78.4	39.2	26.1	19.6	15.7	13.1	11.2	9.8	8.7	7.8
34	87.1	43.6	29.0	21.8	17.4	14.5	12.4	10.9	9.7	8.7
35	100.2	50.1	33.4	25.0	20.0	16.7	14.3	12.5	11.1	10.0
36	117.6	58.8	39.2	29.4	23.5	19.6	16.8	14.7	13.1	11.8
37	130.7	65.3	43.6	32.7	26.1	21.8	18.7	16.3	14.5	13.1
38	148.1	74.1	49.4	37.0	29.6	24.7	21.2	18.5	16.5	14.8
39	165.5	82.8	55.2	41.4	33.1	27.6	23.6	20.7	18.4	16.6
40	183.0	91.5	61.0	45.7	36.6	30.5	26.1	22.9	20.3	18.3
41	200.4	100.2	66.8	50.1	40.1	33.4	28.6	25.0	22.3	20.0
42	222.2	111.1	74.1	55.5	44.4	37.0	31.7	27.8	24.7	22.2
43	243.9	122.0	81.3	61.0	48.8	40.7	34.8	30.5	27.1	24.4
44	265.7	132.9	88.6	66.4	53.1	44.3	38.0	33.2	29.5	26.6
45	283.1	141.6	94.4	70.8	56.6	47.2	40.4	35.4	31.5	28.3
46	304.9	152.5	101.6	76.2	61.0	50.8	43.6	38.1	33.9	30.5
47	331.1	165.5	110.4	82.8	66.2	55.2	47.3	41.4	36.8	33.1
48	352.8	176.4	117.6	88.2	70.6	58.8	50.4	44.1	39.2	35.3
49	370.3	185.1	123.4	92.6	74.1	61.7	52.9	46.3	41.1	37.0
50	396.4	198.2	132.1	99.1	79.3	66.1	56.6	49.5	44.0	39.6
51	422.5	211.3	140.8	105.6	84.5	70.4	60.4	52.8	46.9	42.3
52	448.7	224.3	149.6	112.2	89.7	74.8	64.1	56.1	49.9	44.9
53	474.8	237.4	158.3	118.7	95.0	79.1	67.8	59.4	52.8	47.5
54	500.9	250.5	167.0	125.2	100.2	83.5	71.6	62.6	55.7	50.1
55	522.7	261.4	174.2	130.7	104.5	87.1	74.7	65.3	58.1	52.3
56	557.6	278.8	185.9	139.4	111.5	92.9	79.7	69.7	62.0	55.8
57	592.4	296.2	197.5	148.1	118.5	98.7	84.6	74.1	65.8	59.2
58	627.3	313.6	209.1	156.8	125.5	104.5	89.6	78.4	69.7	62.7
59	662.1	331.1	220.7	165.5	132.4	110.4	94.6	82.8	73.6	66.2
60	697.0	348.5	232.3	174.2	139.4	116.2	99.5	87.1	77.4	69.7
61	731.8	365.9	243.9	183.0	146.4	122.0	104.5	91.5	81.3	73.2
62	771.0	385.5	257.0	192.8	154.2	128.5	110.1	96.4	85.7	77.1
63	805.9	402.9	268.6	201.5	161.2	134.3	115.1	100.7	89.5	80.6
64	845.1	422.5	281.7	211.3	169.0	140.8	120.7	105.6	93.9	84.5
65	884.3	442.1	294.8	221.1	176.9	147.4	126.3	110.5	98.3	88.4
66	914.8	457.4	304.9	228.7	183.0	152.5	130.7	114.3	101.6	91.5
67	949.6	474.8	316.5	237.4	189.9	158.3	135.7	118.7	105.5	95.0
68	984.5	492.2	328.2	246.1	196.9	164.1	140.6	123.1	109.4	98.4
69	1019.3	509.7	339.8	254.8	203.9	169.9	145.6	127.4	113.3	101.9
70	1049.8	524.9	349.9	262.4	210.0	175.0	150.0	131.2	116.6	105.0
71	1067.2	533.6	355.7	266.8	213.4	177.9	152.5	133.4	118.6	106.7
72	1080.3	540.1	360.1	270.1	216.1	180.0	154.3	135.0	120.0	108.0
73	1097.7	548.9	365.9	274.4	219.5	183.0	156.8	167.2	122.0	109.8
74	1110.8	555.4	370.3	277.7	222.2	185.1	158.7	138.8	123.4	111.1
75	1128.2	564.1	376.1	282.1	225.6	188.0	161.2	141.0	125.4	112.8
76	1132.6	566.3	377.5	283.1	226.5	188.8	161.8	141.6	125.8	113.3
77	1136.9	568.5	379.0	284.2	227.4	189.5	162.4	142.1	126.3	113.7
78	1145.6	572.8	381.9	286.4	229.1	190.9	163.7	143.2	127.3	114.6
79	1150.0	575.0	383.3	287.5	230.0	191.7	164.3	143.7	127.8	115.0
80	1154.3	577.2	384.8	288.6	230.9	192.4	164.9	144.3	128.3	115.4

# GENERAL OPERATION

## Centipede Seed Prime Turf

Cam Gauge Settings	Rate in Pounds Per 1,000 Square Feet									
		@ 2.0 Mph	@ 3.0 Mph	@ 4.0 Mph	@ 5.0 Mph	@ 6.0 Mph	@ 7.0 Mph	@ 8.0 Mph	@ 9.0 Mph	@ 10.0 Mph
3	0.1	0.0	0.0	0.0	0.0	0.0	0.0	0.0	0.0	0.0
4	0.3	0.1	0.1	0.1	0.1	0.0	0.0	0.0	0.0	0.0
5	0.4	0.2	0.1	0.1	0.1	0.1	0.1	0.1	0.0	0.0
6	0.7	0.3	0.2	0.2	0.1	0.1	0.1	0.1	0.1	0.1
7	0.9	0.4	0.3	0.2	0.2	0.1	0.1	0.1	0.1	0.1
8	1.1	0.5	0.4	0.3	0.2	0.2	0.2	0.1	0.1	0.1
9	1.4	0.7	0.5	0.3	0.3	0.2	0.2	0.2	0.2	0.1
10	1.6	0.8	0.5	0.4	0.3	0.3	0.2	0.2	0.2	0.2
11	1.9	1.0	0.6	0.5	0.4	0.3	0.3	0.2	0.2	0.2
12	2.3	1.1	0.8	0.6	0.5	0.4	0.3	0.3	0.3	0.2
13	2.6	1.3	0.9	0.6	0.5	0.4	0.4	0.3	0.3	0.3
14	3.0	1.5	1.0	0.8	0.6	0.5	0.4	0.4	0.3	0.3
15	3.5	1.8	1.2	0.9	0.7	0.6	0.5	0.4	0.4	0.4
16	4.0	2.0	1.3	1.0	0.8	0.7	0.6	0.5	0.4	0.4
17	4.5	2.2	1.5	1.1	0.9	0.7	0.6	0.6	0.5	0.4
18	4.9	2.5	1.6	1.2	1.0	0.8	0.7	0.6	0.5	0.5
19	5.7	2.9	1.9	1.4	1.1	1.0	0.8	0.7	0.6	0.6
20	6.5	3.2	2.2	1.6	1.3	1.1	0.9	0.9	0.7	0.6
21	7.1	3.6	2.4	1.8	1.4	1.2	1.0	0.9	0.8	0.7
22	7.8	3.9	2.6	1.9	1.6	1.3	1.1	1.0	0.9	0.8
23	8.5	4.2	2.8	2.1	1.7	1.4	1.2	1.1	0.9	0.8
24	9.6	4.8	3.2	2.4	1.9	1.6	1.4	1.2	1.1	1.0
25	10.7	5.3	3.6	2.7	2.1	1.8	1.5	1.3	1.2	1.1

# GENERAL OPERATION

## Centipede Seed Prime Turf

Cam Gauge Settings	Rate in Pounds Per Acre									
	@ 1.0 Mph	@ 2.0 Mph	@ 3.0 Mph	@ 4.0 Mph	@ 5.0 Mph	@ 6.0 Mph	@ 7.0 Mph	@ 8.0 Mph	@ 9.0 Mph	@ 10.0 Mph
3	4.0	2.0	1.3	1.0	0.8	0.7	0.6	0.5	0.4	0.4
4	11.7	5.8	3.9	2.9	2.3	1.9	1.7	1.5	1.3	1.2
5	19.4	9.7	6.5	4.8	3.9	3.2	2.8	2.4	2.2	1.9
6	28.6	14.3	9.5	7.2	5.7	4.8	4.1	3.6	3.2	2.9
7	37.9	19.0	12.6	9.5	7.6	6.3	5.4	4.7	4.2	3.8
8	47.2	23.6	15.7	11.8	9.4	7.9	6.7	5.9	5.2	4.7
9	59.2	29.6	19.7	14.8	11.8	9.9	8.5	7.4	6.6	5.9
10	71.2	35.6	23.7	17.8	14.2	11.9	10.2	8.9	7.9	7.1
11	84.7	42.3	28.2	21.2	16.9	14.1	12.1	10.6	9.4	8.6
12	98.2	49.1	32.7	24.6	19.6	16.4	14.0	12.3	10.9	9.8
13	111.8	55.9	37.3	27.9	22.4	18.6	16.0	14.0	12.4	11.2
14	132.4	66.2	44.1	33.1	26.5	22.1	18.9	16.6	14.7	13.2
15	153.1	76.6	51.0	38.3	30.6	25.5	21.9	19.1	17.0	15.3
16	173.6	86.8	57.9	43.4	34.7	28.9	24.8	21.7	19.3	17.4
17	194.2	97.1	64.7	48.5	38.8	32.4	27.7	24.3	21.6	19.4
18	214.7	107.4	71.6	53.7	42.9	35.8	30.7	26.8	23.9	21.5
19	248.4	124.2	82.8	62.1	49.7	41.4	35.5	31.0	27.6	24.8
20	282.0	141.0	94.0	70.5	56.4	47.0	40.3	35.3	31.3	28.2
21	310.7	155.3	103.6	77.7	62.1	51.8	44.4	38.8	34.5	31.1
22	339.4	169.7	113.1	84.8	67.9	56.6	48.5	42.4	37.7	33.9
23	368.1	184.0	122.7	92.0	73.6	61.3	52.6	46.0	40.9	36.8
24	416.7	208.3	138.9	104.2	83.3	69.4	59.5	52.1	46.3	41.7
25	465.3	232.7	155.1	116.3	93.1	77.6	66.5	58.2	51.7	46.5

# GENERAL OPERATION

## Penncross Creeping Bentgrass

Cam Gauge Settings	Rate in Pounds Per 1,000 Square Feet									
	@ 1.0 Mph	@ 2.0 Mph	@ 3.0 Mph	@ 4.0 Mph	@ 5.0 Mph	@ 6.0 Mph	@ 7.0 Mph	@ 8.0 Mph	@ 9.0 Mph	@ 10.0 Mph
5	0.2	0.1	0.1	0.1	0.0	0.0	0.0	0.0	0.0	0.0
6	0.4	0.2	0.1	0.1	0.1	0.1	0.1	0.0	0.0	0.0
7	0.5	0.2	0.2	0.1	0.1	0.1	0.1	0.1	0.1	0.0
8	0.6	0.3	0.2	0.2	0.1	0.1	0.1	0.1	0.1	0.1
9	0.7	0.4	0.2	0.2	0.1	0.1	0.1	0.1	0.1	0.1
10	0.9	0.4	0.3	0.2	0.2	0.1	0.1	0.1	0.1	0.1
11	1.1	0.5	0.4	0.3	0.2	0.2	0.2	0.1	0.1	0.1
12	1.3	0.6	0.4	0.3	0.3	0.2	0.2	0.2	0.1	0.1
13	1.5	0.8	0.5	0.4	0.3	0.3	0.2	0.2	0.2	0.2
14	1.7	0.9	0.6	0.4	0.3	0.3	0.2	0.2	0.2	0.2
15	1.9	1.0	0.6	0.5	0.4	0.3	0.3	0.2	0.2	0.2
16	2.3	1.1	0.8	0.6	0.5	0.4	0.3	0.3	0.3	0.2
17	2.6	1.3	0.9	0.7	0.5	0.4	0.4	0.3	0.3	0.3
18	2.9	1.5	1.0	0.7	0.6	0.5	0.4	0.4	0.3	0.3
19	3.3	1.6	1.1	0.8	0.7	0.5	0.5	0.4	0.4	0.3
20	3.6	1.8	1.2	0.9	0.7	0.6	0.5	0.5	0.4	0.4
21	4.1	2.1	1.4	1.0	0.8	0.7	0.6	0.5	0.5	0.4
22	4.6	2.3	1.5	1.2	0.9	0.8	0.7	0.6	0.5	0.5
23	5.1	2.6	1.7	1.3	1.0	0.9	0.7	0.6	0.6	0.5
24	5.6	2.8	1.9	1.4	1.1	0.9	0.8	0.7	0.6	0.6
25	6.1	3.1	2.0	1.5	1.2	1.0	0.9	0.8	0.7	0.6
26	6.7	3.4	2.2	1.7	1.3	1.1	1.0	0.8	0.7	0.7
27	7.3	3.6	2.4	1.8	1.5	1.2	1.0	0.9	0.8	0.7
28	7.9	3.9	2.6	2.0	1.6	1.3	1.1	1.0	0.9	0.8
29	8.5	4.2	2.8	2.1	1.7	1.4	1.2	1.1	0.9	0.8
30	9.1	4.5	3.0	2.3	1.8	1.5	1.3	1.1	1.0	0.9
31	9.8	4.9	3.3	2.4	2.0	1.6	1.4	1.2	1.1	1.0
32	10.5	5.3	3.5	2.6	2.1	1.8	1.5	1.3	1.2	1.1
33	11.3	5.6	3.8	2.8	2.3	1.9	1.6	1.4	1.3	1.1
34	12.0	6.0	4.0	3.0	2.4	2.0	1.7	1.5	1.3	1.2
35	12.7	6.4	4.2	3.2	2.5	2.1	1.8	1.6	1.4	1.3
36	13.7	6.9	4.6	3.4	2.7	2.3	2.0	1.7	1.5	1.4
37	14.7	7.4	4.9	3.7	2.9	2.5	2.1	1.8	1.6	1.5
38	15.7	7.8	5.2	3.9	3.1	2.6	2.2	2.0	1.7	1.6
39	16.7	8.3	5.6	4.2	3.3	2.8	2.4	2.1	1.9	1.7
40	17.7	8.8	5.9	4.4	3.5	2.9	2.5	2.2	2.0	1.8



# GENERAL OPERATION

## Penncross Creeping Bentgrass

Cam Gauge Settings	Rate in Pounds Per Acre									
	@ 1.0 Mph	@ 2.0 Mph	@ 3.0 Mph	@ 4.0 Mph	@ 5.0 Mph	@ 6.0 Mph	@ 7.0 Mph	@ 8.0 Mph	@ 9.0 Mph	@ 10.0 Mph
5	8.7	4.4	2.9	2.2	1.7	1.5	1.2	1.1	1.0	0.9
6	17.4	8.7	5.8	4.4	3.5	2.9	2.5	2.2	1.9	1.7
7	21.8	10.9	7.3	5.4	4.4	3.6	3.1	2.7	2.4	2.2
8	26.1	13.1	8.7	6.5	5.2	4.4	3.7	3.3	2.9	2.6
9	30.5	15.2	10.2	7.6	6.1	5.1	4.4	3.8	3.4	3.0
10	39.2	19.6	13.1	9.8	7.8	6.5	5.6	4.9	4.4	3.9
11	47.9	24.0	16.0	12.0	9.6	8.0	6.8	6.0	5.3	4.8
12	56.6	28.3	18.9	14.2	11.3	9.4	8.1	7.1	6.3	5.7
13	65.3	32.7	21.8	16.3	13.1	10.9	9.3	8.2	7.3	6.5
14	74.1	37.0	24.7	18.5	14.8	12.3	10.6	9.3	8.2	7.4
15	82.8	41.4	27.6	20.7	16.6	13.8	11.8	10.3	9.2	8.3
16	100.2	50.1	33.4	25.0	20.0	16.7	14.3	12.5	11.1	10.0
17	113.3	56.6	37.8	28.3	22.7	18.9	16.2	14.2	12.6	11.3
18	126.3	63.2	42.1	31.6	25.3	21.1	18.0	15.8	14.0	12.6
19	143.7	71.9	47.9	35.9	28.7	24.0	20.5	18.0	16.0	14.4
20	156.8	78.4	52.3	39.2	31.4	26.1	22.4	19.6	17.4	15.7
21	178.6	89.3	59.5	44.6	35.7	29.8	25.5	22.3	19.8	17.9
22	200.4	100.2	66.8	50.1	40.1	33.4	28.6	25.0	22.3	20.0
23	222.2	111.1	74.1	55.5	44.4	37.0	31.7	27.8	24.7	22.2
24	243.9	122.0	81.3	61.0	48.8	40.7	34.8	30.5	27.1	24.4
25	265.7	132.9	88.6	66.4	53.1	44.3	38.0	33.2	29.5	26.6
26	291.9	145.9	97.3	73.0	58.4	48.6	41.7	36.5	32.4	29.2
27	318.0	159.0	106.0	79.5	63.6	53.0	45.4	39.7	35.3	31.8
28	344.1	172.1	114.7	86.0	68.8	57.4	49.2	43.0	38.2	34.4
29	370.3	185.1	123.4	92.6	74.1	61.7	52.9	46.3	41.1	37.0
30	396.4	198.2	132.1	99.1	79.3	66.1	56.6	49.5	44.0	39.6
31	426.9	213.4	142.3	106.7	85.4	71.1	61.0	53.4	47.4	42.7
32	457.4	228.7	152.5	114.3	91.5	76.2	65.3	57.2	50.8	45.7
33	492.2	246.1	164.1	123.1	98.4	82.0	70.3	61.5	54.7	49.2
34	522.7	261.4	174.2	130.7	104.5	87.1	74.7	65.3	58.1	52.3
35	553.2	276.6	184.4	138.3	110.6	92.2	79.0	69.2	61.5	55.3
36	596.8	298.4	198.9	149.2	119.4	99.5	85.3	74.6	66.3	59.7
37	640.3	320.2	213.4	160.1	128.1	106.7	91.5	80.0	71.1	64.0
38	683.9	341.9	228.0	171.0	136.8	114.0	97.7	85.5	76.0	68.4
39	727.5	363.7	242.5	181.9	145.5	121.2	103.9	90.9	80.8	72.7
40	771.0	385.5	257.0	192.8	154.2	128.5	110.1	96.4	85.7	77.1

# GENERAL OPERATION

## Pyramid Bermuda Grass International Seeds Inc.

Cam Gauge Settings	Rate in Pounds Per 1,000 Square Feet									
	@ 1.0 Mph	@ 2.0 Mph	@ 3.0 Mph	@ 4.0 Mph	@ 5.0 Mph	@ 6.0 Mph	@ 7.0 Mph	@ 8.0 Mph	@ 9.0 Mph	@ 10.0 Mph
5	0.7	0.4	0.2	0.2	0.1	0.1	0.1	0.1	0.1	0.1
6	1.1	0.5	0.4	0.3	0.2	0.2	0.2	0.1	0.1	0.1
7	1.4	0.7	0.5	0.4	0.3	0.2	0.2	0.2	0.2	0.1
8	1.8	0.9	0.6	0.4	0.4	0.3	0.3	0.2	0.2	0.2
9	2.1	1.1	0.7	0.5	0.4	0.4	0.3	0.3	0.2	0.2
10	2.5	1.2	0.8	0.6	0.5	0.4	0.4	0.3	0.3	0.2
11	3.1	1.5	1.0	0.8	0.6	0.5	0.4	0.4	0.3	0.3
12	3.6	1.8	1.2	0.9	0.7	0.6	0.5	0.5	0.4	0.4
13	4.2	2.1	1.4	1.0	0.8	0.7	0.6	0.5	0.5	0.4
14	4.7	2.4	1.6	1.2	0.9	0.8	0.7	0.6	0.5	0.5
15	5.3	2.6	1.8	1.3	1.1	0.9	0.8	0.7	0.6	0.5
16	6.1	3.0	2.0	1.5	1.2	1.0	0.9	0.8	0.7	0.6
17	6.9	3.4	2.3	1.7	1.4	1.1	1.0	0.9	0.8	0.7
18	7.6	3.8	2.5	1.9	1.5	1.3	1.1	1.0	0.8	0.8
19	8.4	4.2	2.8	2.1	1.7	1.4	1.2	1.1	0.9	0.8
20	9.2	4.6	3.1	2.3	1.8	1.5	1.3	1.2	1.0	0.9
21	10.3	5.2	3.4	2.6	2.1	1.7	1.5	1.3	1.1	1.0
22	11.5	5.7	3.8	2.9	2.3	1.9	1.6	1.4	1.3	1.1
23	12.6	6.3	4.2	3.2	2.5	2.1	1.8	1.6	1.4	1.3
24	13.8	6.9	4.6	3.4	2.8	2.3	2.0	1.7	1.5	1.4
25	14.9	7.5	5.0	3.7	3.0	2.5	2.1	1.9	1.7	1.5
26	16.4	8.2	5.5	4.1	3.3	2.7	2.3	2.0	1.8	1.6
27	17.9	8.9	6.0	4.5	3.6	3.0	2.6	2.2	2.0	1.8
28	19.4	9.7	6.5	4.8	3.9	3.2	2.8	2.4	2.2	1.9
29	20.8	10.4	6.9	5.2	4.2	3.5	3.0	2.6	2.3	2.1
30	22.3	11.2	7.4	5.6	4.5	3.7	3.2	2.8	2.5	2.2
31	24.3	12.1	8.1	6.1	4.9	4.0	3.5	3.0	2.7	2.4
32	26.2	13.1	8.7	6.6	5.2	4.4	3.7	3.3	2.9	2.6
33	28.1	14.1	9.4	7.0	5.6	4.7	4.0	3.5	3.1	2.8
34	30.1	15.0	10.0	7.5	6.0	5.0	4.3	3.8	3.3	3.0
35	32.0	16.0	10.7	8.0	6.4	5.3	4.6	4.0	3.6	3.2

# GENERAL OPERATION

## Pyramid Bermuda Grass International Seeds Inc.

Cam Gauge Settings	Rate in Pounds Per Acre									
		@ 2.0 Mph	@ 3.0 Mph	@ 4.0 Mph	@ 5.0 Mph	@ 6.0 Mph	@ 7.0 Mph	@ 8.0 Mph	@ 9.0 Mph	@ 10.0 Mph
5	30.5	15.2	10.2	7.6	6.1	5.1	4.4	3.8	3.4	3.0
6	47.9	24.0	16.0	12.0	9.6	8.0	6.8	6.0	5.3	4.8
7	61.0	30.5	20.3	15.2	12.2	10.2	8.7	7.6	6.8	6.1
8	78.4	39.2	26.1	19.6	15.7	13.1	11.2	9.8	8.7	7.8
9	91.5	45.7	30.5	22.9	18.3	15.2	13.1	11.4	10.2	9.1
10	108.9	54.5	36.3	27.2	21.8	18.2	15.6	13.6	12.1	10.9
11	135.0	67.5	45.0	33.8	27.0	22.5	19.3	16.9	15.0	13.5
12	156.8	78.4	52.3	39.2	31.4	26.1	22.4	19.6	17.4	15.7
13	183.0	91.5	61.0	45.7	36.6	30.5	26.1	22.9	20.3	18.3
14	204.7	102.4	68.2	51.2	40.9	34.1	29.2	25.6	22.7	20.5
15	230.9	115.4	77.0	57.7	46.2	38.5	33.0	28.9	25.7	23.1
16	265.7	132.9	88.6	66.4	53.1	44.3	38.0	33.2	29.5	26.6
17	300.6	150.3	100.2	75.1	60.1	50.1	42.9	37.6	33.4	30.1
18	331.1	165.5	110.4	82.8	66.2	55.2	47.3	41.4	36.8	33.1
19	365.9	183.0	122.0	91.5	73.2	61.0	52.3	45.7	40.7	36.6
20	400.8	200.4	133.6	100.2	80.2	66.8	57.3	50.1	44.5	40.1
21	448.7	224.3	149.6	112.2	89.7	74.8	64.1	56.1	49.9	44.9
22	500.9	250.5	167.0	125.2	100.2	83.5	71.6	62.6	55.7	50.1
23	548.9	274.4	183.0	137.2	109.8	91.5	78.4	68.6	61.0	54.9
24	601.1	300.6	200.4	150.3	120.2	100.2	85.9	75.1	66.8	60.1
25	649.0	324.5	216.3	162.3	129.8	108.2	92.7	81.1	72.1	64.9
26	714.4	357.2	238.1	178.6	142.9	119.1	102.1	89.3	79.4	71.4
27	779.7	389.9	259.9	194.9	155.9	130.0	111.4	97.5	86.6	78.0
28	845.1	422.5	281.7	211.3	169.0	140.8	120.7	105.6	93.9	84.5
29	906.0	453.0	302.0	226.5	181.2	151.0	129.4	113.3	100.7	90.6
30	971.4	485.7	323.8	242.8	194.3	161.9	138.8	121.4	107.9	97.1
31	1058.5	529.3	352.8	264.6	211.7	176.4	151.2	132.3	117.6	105.9
32	1141.3	570.6	380.4	285.3	228.3	190.2	163.0	142.7	126.8	114.1
33	1224.0	612.0	408.0	306.0	244.8	204.0	174.9	153.0	136.0	122.4
34	1311.2	655.6	437.1	327.8	262.2	218.5	187.3	163.9	145.7	131.1
35	1393.9	697.0	464.6	348.5	278.8	232.3	199.1	174.2	154.9	139.4

# GENERAL OPERATION

## Flowers and Grass Pickseed West

Cam Gauge Settings	Rate in Pounds Per 1,000 Square Feet									
	@ 1.0 Mph	@ 2.0 Mph	@ 3.0 Mph	@ 4.0 Mph	@ 5.0 Mph	@ 6.0 Mph	@ 7.0 Mph	@ 8.0 Mph	@ 9.0 Mph	@ 10.0 Mph
20	0.3	0.1	0.1	0.1	0.1	0.0	0.0	0.0	0.0	0.0
21	0.3	0.2	0.1	0.1	0.1	0.1	0.0	0.0	0.0	0.0
22	0.3	0.2	0.1	0.1	0.1	0.1	0.0	0.0	0.0	0.0
23	0.4	0.2	0.1	0.1	0.1	0.1	0.1	0.0	0.0	0.0
24	0.4	0.2	0.1	0.1	0.1	0.1	0.1	0.1	0.0	0.0
25	0.4	0.2	0.1	0.1	0.1	0.1	0.1	0.1	0.0	0.0
26	0.5	0.3	0.2	0.1	0.1	0.1	0.1	0.1	0.1	0.1
27	0.6	0.3	0.2	0.1	0.1	0.1	0.1	0.1	0.1	0.1
28	0.6	0.3	0.2	0.2	0.1	0.1	0.1	0.1	0.1	0.1
29	0.7	0.3	0.2	0.2	0.1	0.1	0.1	0.1	0.1	0.1
30	0.7	0.4	0.2	0.2	0.1	0.1	0.1	0.1	0.1	0.1
31	0.5	0.4	0.3	0.2	0.2	0.1	0.1	0.1	0.1	0.1
32	0.9	0.4	0.3	0.2	0.2	0.1	0.1	0.1	0.1	0.1
33	1.0	0.5	0.3	0.2	0.2	0.2	0.1	0.1	0.1	0.1
34	1.0	0.5	0.3	0.3	0.2	0.2	0.1	0.1	0.1	0.1
35	1.1	0.6	0.4	0.3	0.2	0.2	0.2	0.1	0.1	0.1
36	1.2	0.6	0.4	0.3	0.2	0.2	0.2	0.2	0.1	0.1
37	1.3	0.7	0.4	0.3	0.3	0.2	0.2	0.2	0.1	0.1
38	1.4	0.7	0.5	0.4	0.3	0.2	0.2	0.2	0.2	0.1
39	1.5	0.8	0.5	0.4	0.3	0.3	0.2	0.2	0.2	0.2
40	1.6	0.8	0.5	0.4	0.3	0.3	0.2	0.2	0.2	0.2
41	1.8	0.9	0.6	0.5	0.4	0.3	0.3	0.2	0.2	0.2
42	2.1	1.0	0.7	0.5	0.4	0.3	0.3	0.3	0.2	0.2
43	2.3	1.1	0.8	0.6	0.5	0.4	0.3	0.3	0.3	0.2
44	2.5	1.2	0.8	0.6	0.5	0.4	0.4	0.3	0.3	0.2
45	2.7	1.4	0.9	0.7	0.5	0.5	0.4	0.3	0.3	0.3
46	3.0	1.5	1.0	0.7	0.6	0.5	0.4	0.4	0.3	0.3
47	3.3	1.6	1.1	0.8	0.7	0.5	0.5	0.4	0.4	0.3
48	3.6	1.8	1.2	0.9	0.7	0.6	0.5	0.4	0.4	0.4
49	3.9	1.9	1.3	1.0	0.8	0.6	0.6	0.5	0.4	0.4
50	4.1	2.1	1.4	1.0	0.8	0.7	0.6	0.5	0.5	0.4
51	4.6	2.3	1.5	1.1	0.9	0.5	0.7	0.6	0.5	0.5
52	5.0	2.5	1.7	1.3	1.0	0.5	0.7	0.6	0.6	0.5
53	5.5	2.7	1.8	1.4	1.1	0.9	0.5	0.7	0.6	0.5
54	5.9	3.0	2.0	1.5	1.2	1.0	0.8	0.7	0.7	0.6
55	6.4	3.2	2.1	1.6	1.3	1.1	0.9	0.8	0.7	0.6
56	6.7	3.4	2.2	1.7	1.3	1.1	1.0	0.8	0.7	0.7
57	7.1	3.5	2.4	1.8	1.4	1.2	1.0	0.9	0.8	0.7
58	7.5	3.7	2.5	1.9	1.5	1.2	1.1	0.9	0.8	0.7
59	7.8	3.9	2.6	2.0	1.6	1.3	1.1	1.0	0.9	0.8
60	8.2	4.1	2.7	2.1	1.6	1.4	1.2	1.0	0.9	0.8
61	8.6	4.3	2.9	2.2	1.7	1.4	1.2	1.1	1.0	0.9
62	9.1	4.5	3.0	2.3	1.8	1.5	1.3	1.1	1.0	0.9
63	9.5	4.8	3.2	2.4	1.9	1.6	1.4	1.2	1.1	1.0
64	10.0	5.0	3.3	2.5	2.0	1.7	1.4	1.2	1.1	1.0
65	10.4	5.2	3.5	2.6	2.1	1.7	1.5	1.3	1.2	1.0
66	10.8	5.4	3.6	2.7	2.2	1.8	1.5	1.4	1.2	1.1
67	11.3	5.6	3.8	2.8	2.3	1.9	1.6	1.4	1.3	1.1
68	11.7	5.8	3.9	2.9	2.3	1.9	1.7	1.5	1.3	1.2
69	12.1	6.1	4.0	3.0	2.4	2.0	1.7	1.5	1.3	1.2
70	12.6	6.3	4.2	3.1	2.5	2.1	1.8	1.6	1.4	1.3
71	12.9	6.4	4.3	3.2	2.6	2.1	1.8	1.6	1.4	1.3
72	13.2	6.6	4.4	3.3	2.6	2.2	1.9	1.6	1.5	1.3
73	13.5	6.7	4.5	3.4	2.7	2.2	1.9	1.7	1.5	1.3
74	13.8	6.9	4.6	3.5	2.8	2.3	2.0	1.7	1.5	1.4
75	14.1	7.1	4.7	3.5	2.8	2.4	2.0	1.8	1.6	1.4
76	14.2	7.1	4.7	3.6	2.8	2.4	2.0	1.8	1.6	1.4
77	14.3	7.2	4.8	3.6	2.9	2.4	2.0	1.8	1.6	1.4
78	14.4	7.2	4.8	3.6	2.9	2.4	2.1	1.8	1.6	1.4
79	14.5	7.3	4.8	3.6	2.9	2.4	2.1	1.8	1.6	1.5
80	14.6	7.3	4.9	3.7	2.9	2.4	2.1	1.8	1.6	1.5

# GENERAL OPERATION

## Flowers and Grass Pickseed West

Cam Gauge Settings	Rate in Pounds Per Acre									
	@ 1.0 Mph	@ 2.0 Mph	@ 3.0 Mph	@ 4.0 Mph	@ 5.0 Mph	@ 6.0 Mph	@ 7.0 Mph	@ 8.0 Mph	@ 9.0 Mph	@ 10.0 Mph
20	13.1	6.5	4.4	3.3	2.6	2.2	1.9	1.6	1.5	1.3
21	13.1	6.5	4.4	3.3	2.6	2.2	1.9	1.6	1.5	1.3
22	13.1	6.5	4.4	3.3	2.6	2.2	1.9	1.6	1.5	1.3
23	17.4	8.7	5.8	4.4	3.5	2.9	2.5	2.2	1.9	1.7
24	17.4	8.7	5.8	4.4	3.5	2.9	2.5	2.2	1.9	1.7
25	17.4	8.7	5.8	4.4	3.5	2.9	2.5	2.2	1.9	1.7
26	21.8	10.9	7.3	5.4	4.4	3.6	3.1	2.7	2.4	2.2
27	26.1	13.1	8.7	6.5	5.2	4.4	3.7	3.3	2.9	2.6
28	26.1	13.1	8.7	6.5	5.2	4.4	3.7	3.3	2.9	2.6
29	30.5	15.2	10.2	7.6	6.1	5.1	4.4	3.8	3.4	3.0
30	30.5	15.2	10.2	7.6	6.1	5.1	4.4	3.8	3.4	3.0
31	34.8	17.4	11.6	8.7	7.0	5.8	5.0	4.4	3.9	3.5
32	39.2	19.6	13.1	9.8	7.8	6.5	5.6	4.9	4.4	3.9
33	43.6	21.8	14.5	10.9	8.7	7.3	6.2	5.4	4.8	4.4
34	43.6	21.8	14.5	10.9	8.7	7.3	6.2	5.4	4.8	4.4
35	47.9	24.0	16.0	12.0	9.6	8.0	6.8	6.0	5.3	4.8
36	52.3	26.1	17.4	13.1	10.5	8.7	7.5	6.5	5.8	5.2
37	56.6	28.3	18.9	14.2	11.3	9.4	8.1	7.1	6.3	5.7
38	61.0	30.5	20.3	15.2	12.2	10.2	8.7	7.6	6.8	6.1
39	65.3	32.7	21.8	16.3	13.1	10.9	9.3	8.2	7.3	6.5
40	69.7	34.8	23.2	17.4	13.9	11.6	10.0	8.7	7.7	7.0
41	78.4	39.2	26.1	19.6	15.7	13.1	11.2	9.8	8.7	7.8
42	91.5	45.7	30.5	22.9	18.3	15.2	13.1	11.4	10.2	9.1
43	100.2	50.1	33.4	25.0	20.0	16.7	14.3	12.5	11.1	10.0
44	108.9	54.5	36.3	27.2	21.8	18.2	15.6	13.6	12.1	10.9
45	117.6	58.8	39.2	29.4	23.5	19.6	16.8	14.7	13.1	11.8
46	130.7	65.3	43.6	32.7	26.1	21.8	18.7	16.3	14.5	13.1
47	143.7	71.9	47.9	35.9	28.7	24.0	20.5	18.0	16.0	14.4
48	156.8	78.4	52.3	39.2	31.4	26.1	22.4	19.6	17.4	15.7
49	169.9	84.9	56.6	42.5	34.0	28.3	24.3	21.2	18.9	17.0
50	178.6	89.3	59.5	44.6	35.7	29.8	25.5	22.3	19.8	17.9
51	200.4	100.2	66.8	50.1	40.1	33.4	28.6	25.0	22.3	20.0
52	217.8	108.9	72.6	54.5	43.6	36.3	31.1	27.2	24.2	21.8
53	239.6	119.8	79.9	59.9	47.9	39.9	34.2	29.9	26.6	24.0
54	257.0	128.5	85.7	64.3	51.4	42.8	36.7	32.1	28.6	25.7
55	278.8	139.4	92.9	69.7	55.8	46.5	39.8	34.8	31.0	27.9
56	291.9	145.9	97.3	73.0	58.4	48.6	41.7	36.5	32.4	29.2
57	309.3	154.6	103.1	77.3	61.9	51.5	44.2	38.7	34.4	30.9
58	326.7	163.4	108.9	81.7	65.3	54.5	46.7	40.8	36.3	32.7
59	339.8	169.9	113.3	84.9	68.0	56.6	48.5	42.5	37.8	34.0
60	357.2	178.6	119.1	89.3	71.4	59.5	51.0	44.6	39.7	35.7
61	374.6	187.3	124.9	93.7	74.9	62.4	53.5	46.8	41.6	37.5
62	396.4	198.2	132.1	99.1	79.3	66.1	56.6	49.5	44.0	39.6
63	413.8	206.9	137.9	103.5	82.8	69.0	59.1	51.7	46.0	41.4
64	435.6	217.8	145.2	108.9	87.1	72.6	62.2	54.5	48.4	43.6
65	453.0	226.5	151.0	113.3	90.6	75.5	64.7	56.6	50.3	45.3
66	470.4	235.2	156.8	117.6	94.1	78.4	67.2	58.8	52.3	47.0
67	492.2	246.1	164.1	123.1	98.4	82.0	70.3	61.5	54.7	49.2
68	509.7	254.8	169.9	127.4	101.9	84.9	72.8	63.7	56.6	51.0
69	527.1	263.5	175.7	131.8	105.4	87.8	75.3	65.9	58.6	52.7
70	548.9	274.4	183.0	137.2	109.8	91.5	78.4	68.6	61.0	54.9
71	561.9	281.0	187.3	140.5	112.4	93.7	80.3	70.2	62.4	56.2
72	575.0	287.5	191.7	143.7	115.0	95.8	82.1	71.9	63.9	57.5
73	588.1	294.0	196.0	147.0	117.6	98.0	84.0	73.5	65.3	58.8
74	601.1	300.6	200.4	150.3	120.2	100.2	85.9	75.1	66.8	60.1
75	614.2	307.1	204.7	153.5	122.8	102.4	87.7	76.8	68.2	61.4
76	618.6	309.3	206.2	154.6	123.7	103.1	88.4	77.3	68.7	61.9
77	622.9	311.5	207.6	155.7	124.6	103.8	89.0	77.9	69.2	62.3
78	627.3	313.6	209.1	156.8	125.5	104.5	89.6	78.4	69.7	62.7
79	631.6	315.8	210.5	157.9	126.3	105.3	90.2	79.0	70.2	63.2
80	636.0	318.0	212.0	159.0	127.2	106.0	90.9	79.5	70.7	63.6

# GENERAL OPERATION

## Perennial Rye Grass Medalist Gold #1

Cam Gauge Settings	Rate in Pounds Per 1,000 Square Feet									
	@ 1.0 Mph	@ 2.0 Mph	@ 3.0 Mph	@ 4.0 Mph	@ 5.0 Mph	@ 6.0 Mph	@ 7.0 Mph	@ 8.0 Mph	@ 9.0 Mph	@ 10.0 Mph
40	2.6	1.4	0.9	0.7	0.6	0.5	0.4	0.4	0.3	0.3
41	3.2	1.6	1.1	0.8	0.6	0.5	0.5	0.4	0.4	0.3
42	3.6	1.8	1.2	0.9	0.7	0.6	0.5	0.5	0.4	0.4
43	4.0	2.0	1.3	1.0	0.8	0.7	0.6	0.5	0.4	0.4
44	4.4	2.2	1.5	1.1	0.9	0.7	0.6	0.6	0.5	0.4
45	4.8	2.4	1.6	1.2	1.0	0.8	0.7	0.6	0.5	0.5
46	5.4	2.7	1.8	1.3	1.1	0.9	0.8	0.7	0.6	0.5
47	6.0	3.0	2.0	1.5	1.2	1.0	0.9	0.7	0.7	0.6
48	6.5	3.3	2.2	1.6	1.3	1.1	0.9	0.8	0.7	0.7
49	7.1	3.6	2.4	1.8	1.4	1.2	1.0	0.9	0.8	0.7
50	7.7	3.8	2.6	1.9	1.5	1.3	1.1	1.0	0.9	0.8
51	8.3	4.1	2.8	2.1	1.7	1.4	1.2	1.0	0.9	0.8
52	8.8	4.4	2.9	2.2	1.8	1.5	1.3	1.1	1.0	0.9
53	9.4	4.7	3.1	2.3	1.9	1.6	1.3	1.2	1.0	0.9
54	9.9	5.0	3.3	2.5	2.0	1.7	1.4	1.2	1.1	1.0
55	10.5	5.3	3.5	2.6	2.1	1.8	1.5	1.3	1.2	1.1
56	11.1	5.6	3.7	2.8	2.2	1.9	1.6	1.4	1.2	1.1
57	11.8	5.9	3.9	2.9	2.4	2.0	1.7	1.5	1.3	1.2
58	12.4	6.2	4.1	3.1	2.5	2.1	1.8	1.6	1.4	1.2
59	13.0	6.5	4.3	3.3	2.6	2.2	1.9	1.6	1.4	1.3
60	13.7	6.8	4.6	3.4	2.7	2.3	2.0	1.7	1.5	1.4
61	14.3	7.2	4.8	3.6	2.9	2.4	2.0	1.8	1.6	1.4
62	15.0	7.5	5.0	3.7	3.0	2.5	2.1	1.9	1.7	1.5
63	15.6	7.8	5.2	3.9	3.1	2.6	2.2	2.0	1.7	1.6
64	16.3	8.1	5.4	4.1	3.3	2.7	2.3	2.0	1.8	1.6
65	16.9	8.5	5.6	4.2	3.4	2.8	2.4	2.1	1.9	1.7
66	17.8	8.9	5.9	4.4	3.6	3.0	2.5	2.2	2.0	1.8
67	18.6	9.3	6.2	4.7	3.7	3.1	2.7	2.3	2.1	1.9
68	19.4	9.7	6.5	4.9	3.9	3.2	2.8	2.4	2.2	1.9
69	20.3	10.1	6.8	5.1	4.1	3.4	2.9	2.5	2.3	2.0
70	21.1	10.6	7.0	5.3	4.2	3.5	3.0	2.6	2.3	2.1
71	21.8	10.9	7.3	5.5	4.4	3.6	3.1	2.7	2.4	2.2
72	22.6	11.3	7.5	5.6	4.5	3.8	3.2	2.8	2.5	2.3
73	23.3	11.6	7.8	5.8	4.7	3.9	3.3	2.9	2.6	2.3
74	24.0	12.0	8.0	6.0	4.8	4.0	3.4	3.0	2.7	2.4
75	24.7	12.4	8.2	6.2	4.9	4.1	3.5	3.1	2.7	2.5
76	24.8	12.4	8.3	6.2	5.0	4.1	3.5	3.1	2.8	2.5
77	24.9	12.4	8.3	6.2	5.0	4.1	3.6	3.1	2.8	2.5
78	24.9	12.5	8.3	6.2	5.0	4.2	3.6	3.1	2.8	2.5
79	25.0	12.5	8.3	6.2	5.0	4.2	3.6	3.1	2.8	2.5
80	25.1	12.5	8.4	6.3	5.0	4.2	3.6	3.1	2.8	2.5

# GENERAL OPERATION

## Perennial Rye Grass Medalist Gold #1

Cam Gauge Settings	Rate in Pounds Per Acre									
	@ 1.0 Mph	@ 2.0 Mph	@ 3.0 Mph	@ 4.0 Mph	@ 5.0 Mph	@ 6.0 Mph	@ 7.0 Mph	@ 8.0 Mph	@ 9.0 Mph	@ 10.0 Mph
40	122.0	61.0	40.7	30.5	24.4	20.3	17.4	15.2	13.6	12.2
41	139.4	69.7	46.5	34.8	27.9	23.2	19.9	17.4	15.5	13.9
42	156.8	78.4	52.3	39.2	31.4	26.1	22.4	19.6	17.4	15.7
43	174.2	87.1	58.1	43.6	34.8	29.0	24.9	21.8	19.4	17.4
44	191.7	95.8	63.9	47.9	38.3	31.9	27.4	24.0	21.3	19.2
45	209.1	104.5	69.7	52.3	41.8	34.8	29.9	26.1	23.2	20.9
46	235.2	117.6	78.4	58.8	47.0	39.2	33.6	29.4	26.1	23.5
47	261.4	130.7	87.1	65.3	52.3	43.6	37.3	32.7	29.0	26.1
48	283.1	141.6	94.4	70.8	56.6	47.2	40.4	35.4	31.5	28.3
49	309.3	154.6	103.1	77.3	61.9	51.5	44.2	38.7	34.4	30.9
50	335.4	167.7	111.8	83.9	67.1	55.9	47.9	41.9	37.3	33.5
51	361.5	180.8	120.5	90.4	72.3	60.3	51.6	45.2	40.2	36.2
52	383.3	191.7	127.8	95.8	76.7	63.9	54.8	47.9	42.6	38.3
53	409.5	204.7	136.5	102.4	81.9	68.2	58.5	51.2	45.5	40.9
54	431.2	215.6	143.7	107.8	86.2	71.9	61.6	53.9	47.9	43.1
55	457.4	228.7	152.5	114.3	91.5	76.2	65.3	57.2	50.8	45.7
56	483.5	241.8	161.2	120.9	96.7	80.6	69.1	60.4	53.7	48.4
57	514.0	257.0	171.3	128.5	102.8	85.7	73.4	64.3	57.1	51.4
58	540.1	270.1	180.0	135.0	108.0	90.0	77.2	67.5	60.0	54.0
59	566.3	283.1	188.8	141.6	113.3	94.4	80.9	70.8	62.9	56.6
60	596.8	298.4	198.9	149.2	119.4	99.5	85.3	74.6	66.3	59.7
61	622.9	311.5	207.6	155.7	124.6	103.8	89.0	77.9	69.2	62.3
62	653.4	326.7	217.8	163.4	130.7	108.9	93.3	81.7	72.6	65.3
63	679.5	339.8	226.5	169.9	135.9	113.3	97.1	84.9	75.5	68.0
64	710.0	355.0	236.7	177.5	142.0	118.3	101.4	88.8	78.9	71.0
65	736.2	368.1	245.4	184.0	147.2	122.7	105.2	92.0	81.8	73.6
66	775.4	387.7	258.5	193.8	155.1	129.2	110.8	96.9	86.2	77.5
67	810.2	405.1	270.1	202.6	162.0	135.0	115.7	101.3	90.0	81.0
68	845.1	422.5	281.7	211.3	169.0	140.8	120.7	105.6	93.9	84.5
69	884.3	442.1	294.8	221.1	176.9	147.4	126.3	110.5	98.3	88.4
70	919.1	459.6	306.4	229.8	183.8	153.2	131.3	114.9	102.1	91.9
71	949.6	474.8	316.5	237.4	189.9	158.3	135.7	118.7	105.5	95.0
72	984.5	492.2	328.2	246.1	196.9	164.1	140.6	123.1	109.4	98.4
73	1014.9	507.5	338.3	253.7	203.0	169.2	145.0	126.9	112.8	101.5
74	1045.4	522.7	348.5	261.4	209.1	174.2	149.3	130.7	116.2	104.5
75	1075.9	538.0	358.6	269.0	215.2	179.3	153.7	134.5	119.5	107.6
76	1080.3	540.1	360.1	270.1	216.1	180.0	154.3	135.0	120.0	108.0
77	1084.6	542.3	361.5	271.2	216.9	180.8	154.9	135.6	120.5	108.5
78	1084.6	542.3	361.5	271.2	216.9	180.8	154.9	135.6	120.5	108.5
79	1089.0	544.5	363.0	272.3	217.8	181.5	155.6	136.1	121.0	108.9
80	1093.4	546.7	364.5	273.3	218.7	182.2	156.2	136.7	121.5	109.3



# SERVICE

## ⚠ WARNING

Always set the parking brake, shut off power unit engine, remove the ignition key, and ensure all moving parts have come to a complete stop before inspecting components or attempting any repair or adjustment.



## Attention

If any component requires replacement, use only original Ventrac replacement parts.

### Cleaning and General Maintenance

For best results, and to maintain the finish of the AERA-vator, clean or wash the AERA-vator to remove dirt and debris when the job is finished.

### Cleaning of Optional Seeder

For best results, empty remaining product from the seeder hopper and clean the seeder after the job is finished. Do not allow product to sit in the hopper, as compaction of product may occur. Dirt accumulations or poor maintenance may affect the performance of the seeder (e.g. a partially blocked hopper opening and/or spout tube will not dispense the product properly).

1. Empty any remaining product from the seeder's hopper by discharging onto a tarp.
2. Close the shut off lever.
3. Place a container under the left hopper end to catch any remaining product.
4. Loosen the bearing retainer wing nut and turn the bearing retainer out of the way. Using a rotating motion, slowly pull the bearing and rotor bar out of the hopper, allowing any product to fall into the container.

## ⚠ CAUTION

Under normal load, the motor will run hot to the touch. Allow the motor to cool before performing work on or near the motor.

5. Remove the motor cover and drive chain from the right hopper end.
6. Repeat steps 3 & 4 for the right end bearing and rotor bar.
7. Loosen the center bearing retainer and remove the center bearing from the hopper.
8. Remove the seeder from the AERA-vator frame.

9. Remove the wing nuts and clips holding the spout/drop tube assembly to the bottom of the hopper.
10. Wipe clean the inner surfaces of the hopper, the hopper bottom and slide plates, and the spout/drop tube plate.
11. Inspect spout tubes for blockages and clean if necessary.
12. Reinstall the spout/drop tube assembly to the bottom of the hopper and fasten with the clips and wing nuts.
13. Reinstall the center bearing and tighten the bearing retainer.
14. Reinstall the seeder onto the AERA-vator frame, unless preparing for storage. Torque the nuts and bolts that fasten the end mounting brackets to the AERA-vator to 31 ft-lbs (42 Nm).
15. Using a rotating motion, reinsert the left and right rotor bars and end bearings into the hopper. Rotate the bearing retainers into place and tighten the wing nuts.
16. Reinstall the drive chain and motor cover.

### Belt Inspection

Inspecting the drive belts of the AERA-vator can prevent sudden belt failure by finding problems before they cause a belt to break.

Typical wear on a drive belt may result in the conditions shown in the diagram. If any of these conditions occur, the drive belt will require replacement.

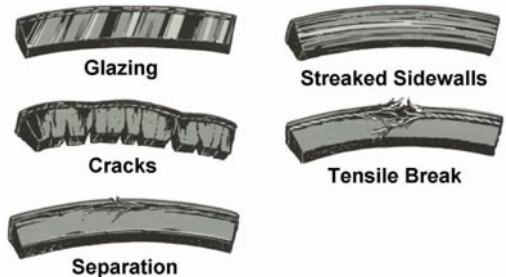

### Gearbox Drive Belt Replacement

1. Detach the AERA-vator from the power unit.
2. Remove the 4 bolts that fasten the belt shield (A) to the top of the gearbox.

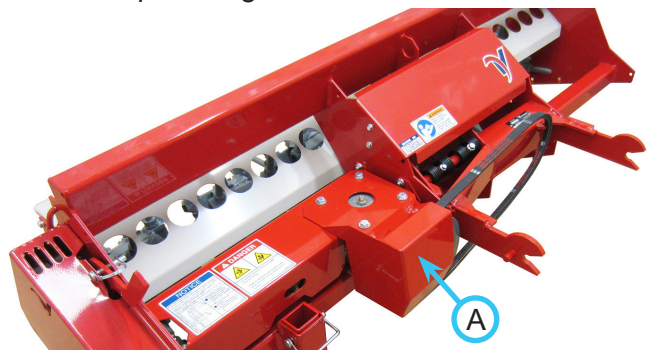

3. Remove the old drive belt.

# SERVICE

4. Install the new drive belt over the pulley and reinstall the belt shield onto the gearbox. Torque bolts to 31 ft-lbs (42 Nm).

## Triple Drive Belt Replacement

1. Detach the AERA-vator from the power unit.
2. Remove the lockout pin from the clutch handle.
3. Remove the belt shield (A) from the left side of the AERA-vator.
4. Remove the belt retainer (B) and the two belt retainer bolts (C) from the left side of the AERA-vator.

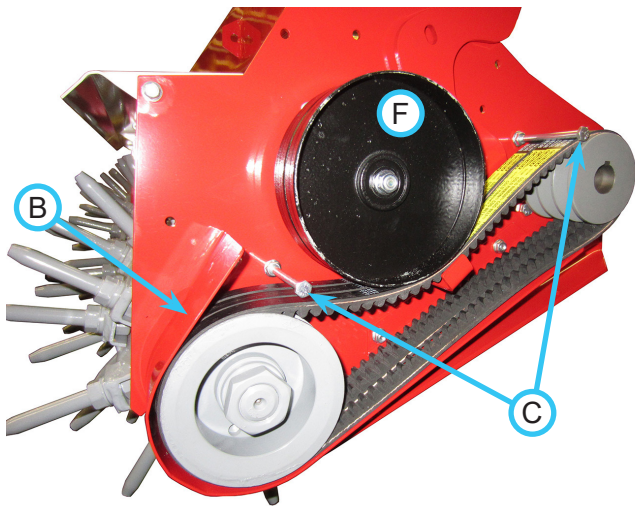
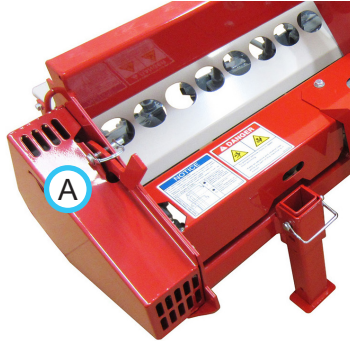

5. Pull the clutch handle back until the hole for the lockout pin is past the AERA-vator frame. Install the lockout pin (D) and release the clutch handle. The bolt head (E) for the clutch pulley should now be aligned with the access hole in the main frame.

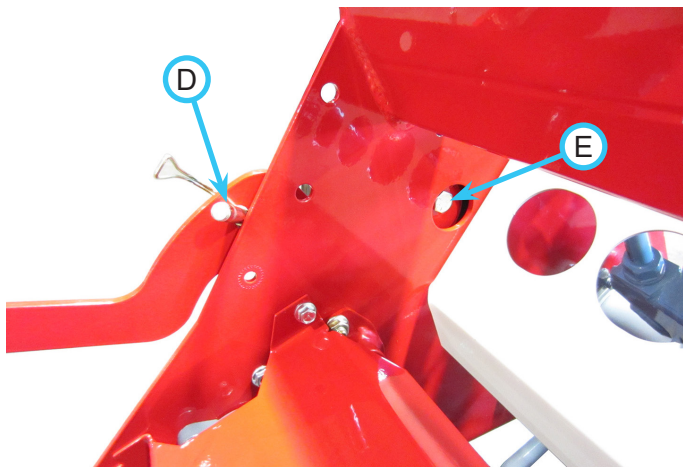

6. Remove the clutch pulley (F) from the clutch handle.
7. Remove the old drive belts and install the new drive belts onto the pulleys. Replace all 3) drive belts at the same time. NOTE: due to manufacturing tolerances on the belt length, if possible, choose three belts that are closest in length to each other.
8. Reinstall the two belt retainer bolts (C). Torque to 100 in-lbs (11 Nm).
9. Reinstall the clutch pulley (F) onto the clutch handle. Torque to 31 ft-lbs (42 Nm).
10. Remove the lockout pin (D) and release the clutch handle to tension the belts.
11. Reinstall the belt retainer (B) and check to ensure there is approximately 1/16" (1.5 mm) gap between the belt retainer and the belts around the front pulley. Torque bolts to 100 in-lbs (11 Nm).
12. Before reinstalling the belt shield (A), check for proper belt adjustment. Refer to the following section for belt adjustment instructions.

## Triple Drive Belt Adjustment

1. Attach the AERA-vator to the power unit.
2. Park the power unit and AERA-vator on a dirt surface and engage the parking brake.
3. Engage the PTO and lower the AERA-vator to the ground to activate the tine drive.
4. After tine movement has started, lift the AERA-vator off the ground. The belt slack should push back and move the belts away from the rear of the drive pulley (G). The drive pulley will continue to spin with the PTO engaged, but belt movement should stop within 5-10 seconds after the AERA-vator is lifted off the ground.





# SERVICE

5. If the belts do not disengage properly, you may need to adjust the bottom of the belt retainer shield (B), the belt retainer bolt (C) next to the rear drive pulley, or the clutch linkage (H) under the shield in front of the hitch arms.

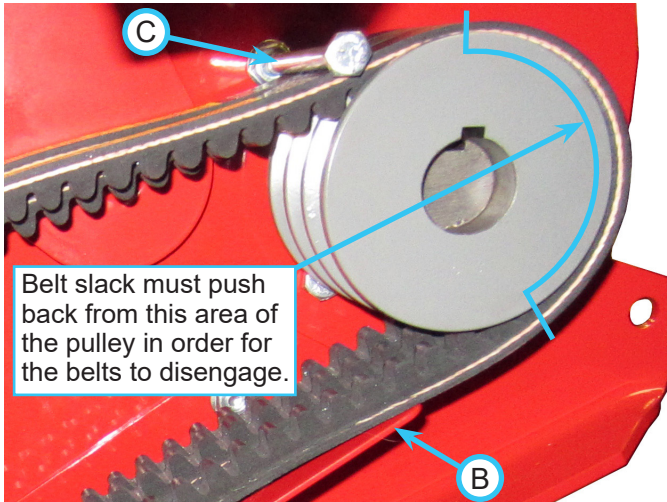

NOTE: the belt retainer bolt (C) and the bottom of the belt retainer shield (B) must keep the belt from moving very far away from the top or bottom of the drive pulley (G) to ensure the belt disengages from the rear of the drive pulley where the belt wraps around the pulley.

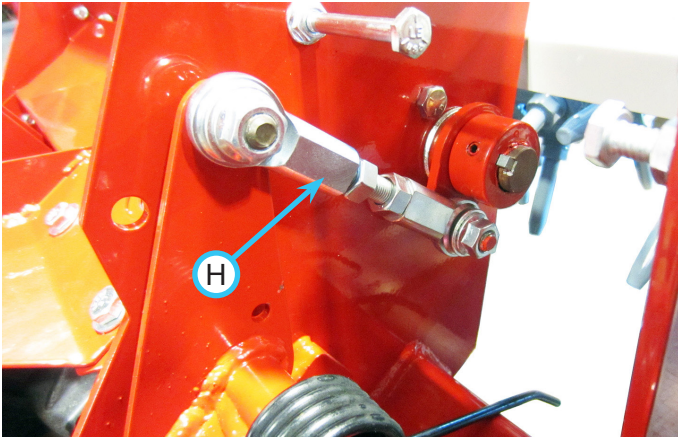

NOTE: shorten the clutch linkage (H) to move the clutch pulley (F) down toward the belt. Lengthen the clutch linkage to move the clutch pulley up away from the belts.

6. Repeat steps 3 and 4 until the belts disengage within the required time limit.
7. If the clutch linkage length was adjusted, make sure the locking nuts are tightened against the rod ends.
8. Reinstall the belt shield (A) and torque bolts to 100 in-lbs (11 Nm).
9. Reinstall the lockout pin in the desired position.

## Drive Chain Tension Inspection (Optional Seeder)

1. Unplug the seeder power cord from the power unit.

### CAUTION

Under normal load, the motor will run hot to the touch. Allow the motor to cool before performing work on or near the motor.

2. Remove the motor cover from the right end of the seeder hopper.
3. Place a straightedge across the sprockets as shown below.

4. Lightly press on the chain at the center point between the sprockets to remove the slack. There should be  $5/16'' \pm 1/16''$  ( $8 \text{ mm} \pm 1.5 \text{ mm}$ ) between the chain and the straightedge.

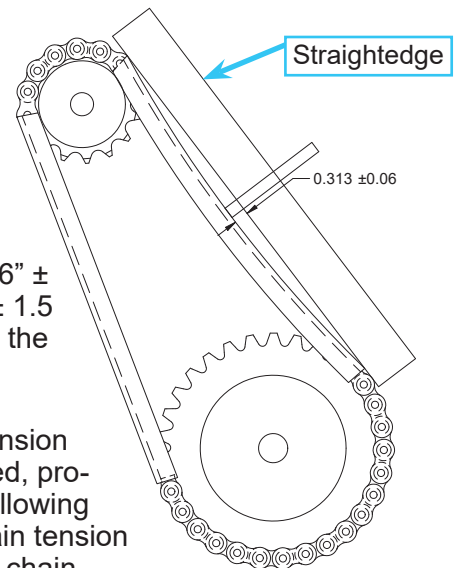

5. If the chain tension needs adjusted, proceed to the following section of chain tension adjustment. If chain tension is correct, reinstall the motor cover and torque the bolts to 100 in-lbs (11 Nm).

## Drive Chain Tension Adjustment (Optional Seeder)

1. Loosen the 2) bolts that fasten the motor mount to the right side seeder mount.
2. Move the motor mount to increase or decrease the chain tension and torque the motor mount bolts to 210 in-lbs (24 Nm).
3. Reconnect the seeder plug to the power unit and run the seeder for 20-30 seconds.
4. Unplug the seeder from the power unit and recheck the chain tension.
5. When chain tension is correct, reinstall the motor cover and torque the bolts to 100 in-lbs (11 Nm).

# SERVICE

## Lubrication Locations

Lubrication is required at the following locations. Refer to the maintenance schedule for service intervals and amount of grease.



lithium complex  
NLGI #2 grease



low viscosity oil

Bearing & Universal Joint

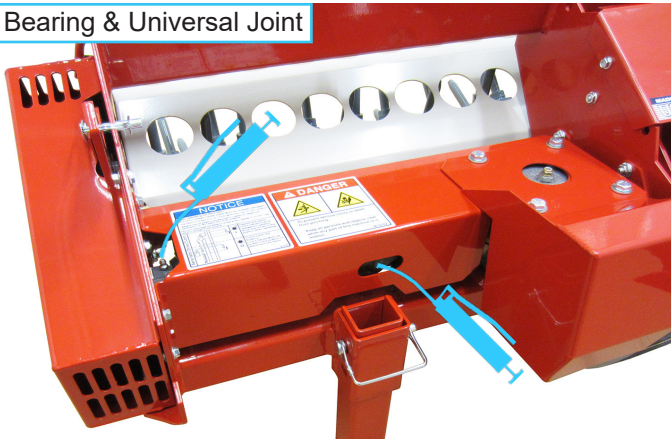

Optional Rear Roller Bearings

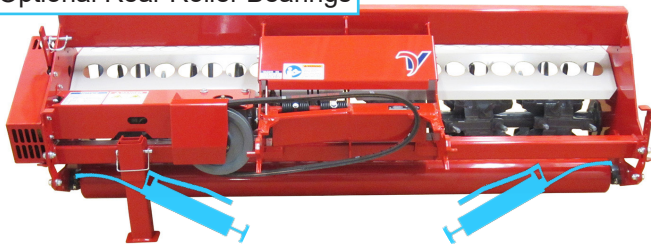

Optional Seeder Drive Chain

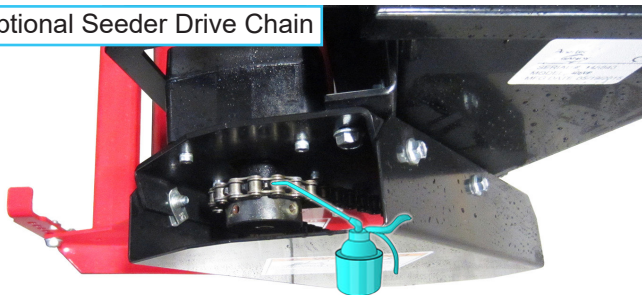

Optional Seeder Rotor Bearings (4 places)

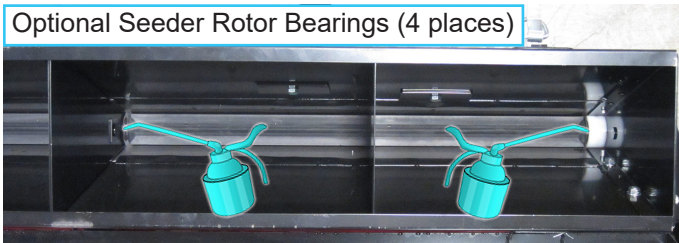

NOTE: to oil the seeder rotor bearings, place 3-4 drops of oil between the rotor ends and the rotor bearings. The bearings are oil impregnated and will replenish themselves to their absorption capacity. Do not over-oil.

## Checking Gearbox Oil Level

1. Clean the top of the gearbox and remove the breather plug (A) from the top port.

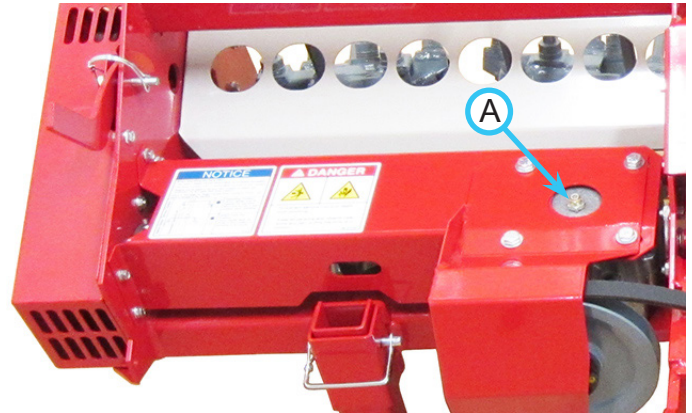

2. Check the oil level in the gearbox. The oil level should be maintained at approximately half full. If oil level is low, add 80-90 synthetic gear oil until the proper level is reached.
3. Reinstall the breather plug into the top port of the gearbox.

## Changing Gearbox Oil

Due to the gearbox mounting configuration, the gearbox does not have a bottom drain port. The recommended procedure is to remove the gear oil using a fluid extractor or have this service procedure performed by an authorized dealer.

1. Clean the top of the gearbox and remove the breather plug from the top port.
2. Use a fluid extractor to remove the old gear oil from the gearbox.
3. Add 80-90 synthetic gear oil until the proper level is reached.
4. Reinstall the breather plug into the top port of the gearbox.

# SERVICE

## Storage

### Preparing the AERA-vator for Storage

1. Clean the AERA-vator.
2. Inspect for loose or missing hardware, damaged components, or signs of wear. Repair or replace as necessary.
3. Inspect safety decals. Replace any safety decals that are faded, illegible, or missing.
4. Inspect belts for signs of damage or wear and replace as required.
5. Service all lubrication points and inspect gearbox oil level.
6. Wipe off excess grease or oil.
7. Place the AERA-vator on concrete or on wood blocks for seasonal storage.

### Removing the AERA-vator from Storage

1. Clean the AERA-vator to remove any accumulated dust or debris.
2. Inspect the AERA-vator as instructed in the daily inspection section of this manual.
3. Test the AERA-vator to ensure all components are working properly.

## Rotor Shaft Service Instructions

Clean the AERA-vator thoroughly with a pressure washer before servicing the rotor shaft.

### Rotor Shaft Removal

1. Remove the AERA-vator from the power unit and place on a level surface beneath a hoist.
2. Remove the three belt shield, the belt retainer, and the three drive belts.
3. Remove the 3/8" nuts and bolts that fasten the center bearing to the center bearing mount.
4. Remove the 3/8" nuts and carriage bolts that fasten the end rotor shaft bearings to the frame.  
NOTE: the carriage bolts on the pulley end will be captive between the pulley and the bearing flange.
5. Use a hoist to lift up slightly on the AERA-vator frame while moving the frame to the right until the carriage bolts clear the frame.
6. Lift the AERA-vator off the rotor shaft assembly and move out of the way. Lower the AERA-vator to the ground before continuing work on the rotor shaft.

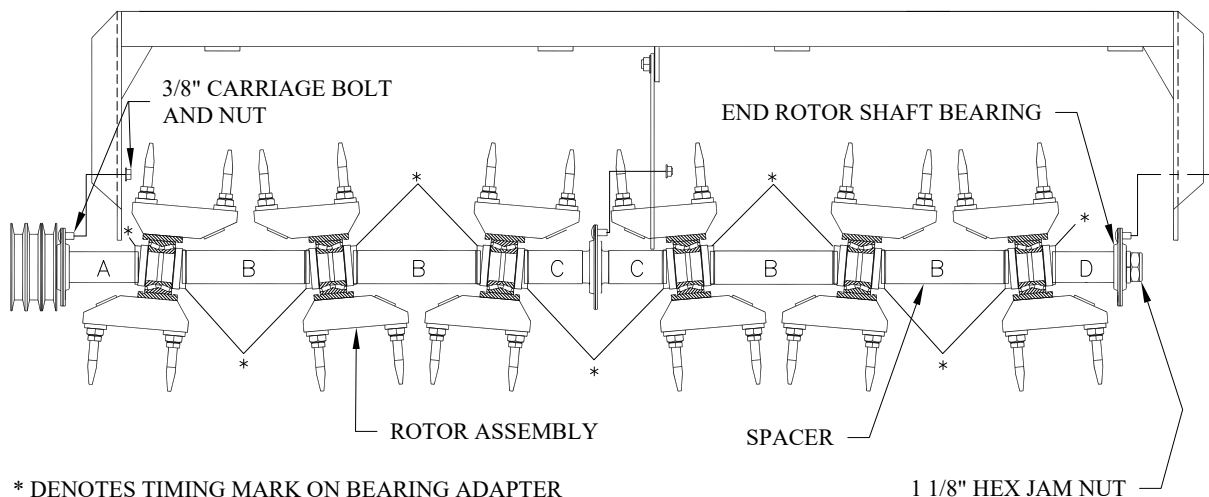

\* DENOTES TIMING MARK ON BEARING ADAPTER

- NOTES: 1. EACH ROTOR ASSEMBLY HAS THE TIMING MARKS PHASED 180° APART ON OPPOSITE SIDES.  
2. THE TIMING MARKS BETWEEN ADJACENT ROTORS ARE ALIGNED, INCLUDING THE CENTER PAIR OF ROTORS.



# SERVICE

## Rotor Shaft Disassembly

1. Remove the 1-1/8" hex jam nut from the shaft end nearest the damaged component.
2. Only remove the rotors and spacers required to reach the damaged component. Wipe the shaft clean before each rotor is removed.



### Attention

Each rotor bearing has two separate cones with a hex bore adapter pressed into each. Each cone is held in position by an internal grease seal, which allows the cones to be moved apart slightly. If they are moved apart, any dirt allowed inside the hex adapters can fall between the cones and contaminate the bearing.

If the cones are forced apart, the internal seals become ruined and irreplaceable.

3. Place a blunt bar against the thick face of the bearing adapter to drive the rotors off the shaft.

NOTE: applying force against the rotors or tines when removing rotor assemblies will ruin the irreplaceable internal rotor seals.

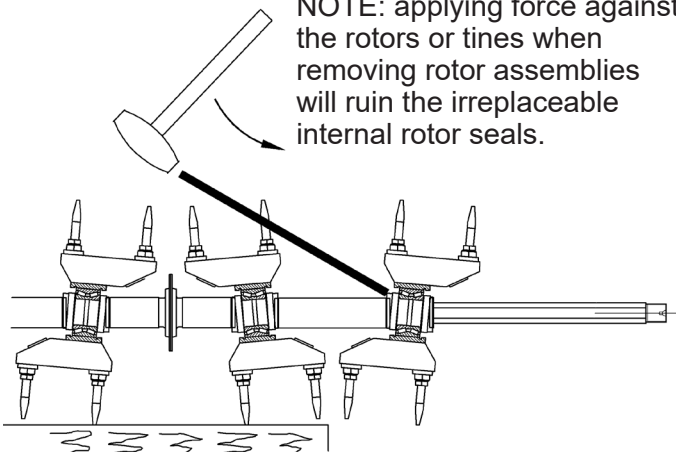

4. Clean and inspect parts as they are removed and set aside in their order of removal.

## Rotor Hub Disassembly

1. With a pry bar, remove the external seals on both sides of the rotor. Generally, seals are damaged and are not reusable.

EXTERNAL SEAL - STEP 1

SNAP RING - STEP 2

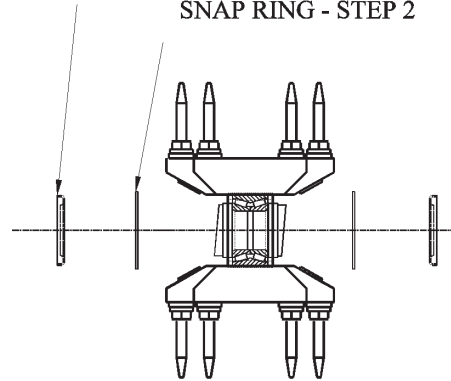

2. Remove the snap rings on both sides of the rotor.
3. Press the used bearing and adapter assembly out of the rotor.

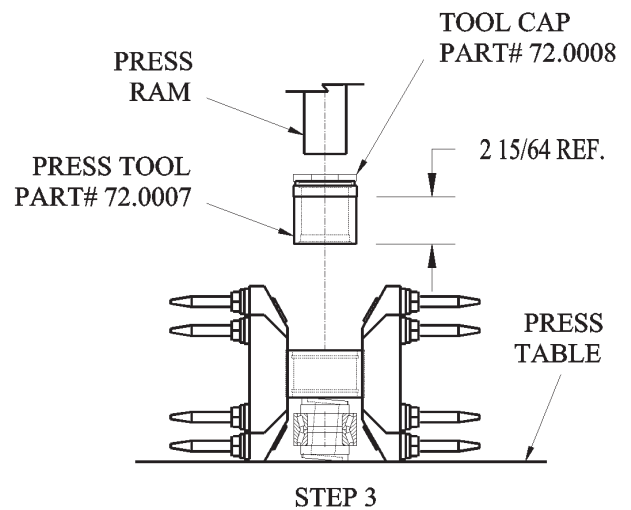

# SERVICE

## Rotor Hub Reassembly



### Attention

Keep all components clean to prevent bearing contamination.

1. Install snap ring in one side of rotor hub.  
NOTE: be sure snap rings expand full depth into the grooves.
2. Press the new bearing and adapter assembly down tight against the snap ring. NOTE: if bearing is loose in the hub, the rotor should be replaced.

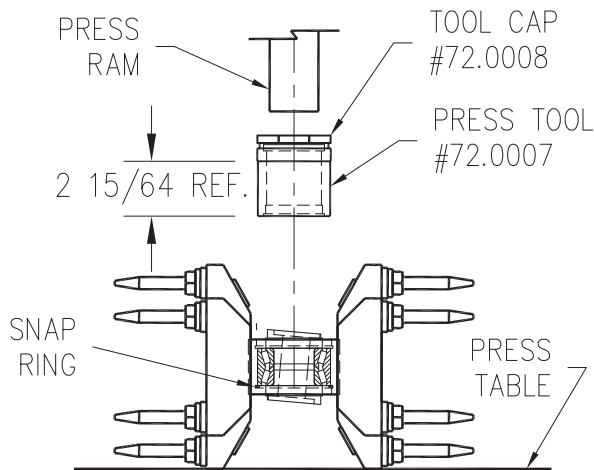

3. Install snap ring in other end of rotor hub.
4. Apply a ribbon of general purpose grease between the snap ring ID and the bearing adapter OD on both ends of the rotor hub.
5. With the press tool inverted to fit the external seals, press seals in both ends of the rotor with the lips out. Wipe off excess grease. Be sure the seals are not bent or cut and are seated firmly. If the seals are not tight, use a hammer and punch to stake the hub faces at approximately 90 degree intervals.

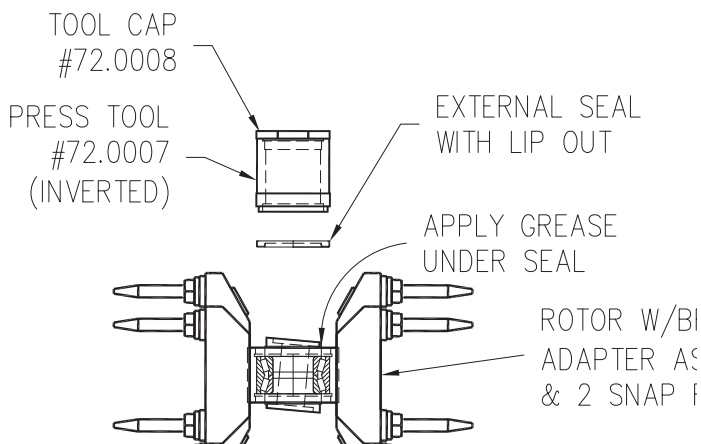

## Rotor Shaft Reassembly



### Attention

Read this section thoroughly before beginning.

### CAUTION

Clean the rotor shaft and remove any burrs that would keep the rotor assemblies from sliding on freely. If a bearing adapter jams, the internal bearing seal could be forced out and it is not replaceable.

### CAUTION

If the bearing adapters are not precisely timed 180 degrees apart in each rotor and aligned between rotors, serious damage will result.

1. Rotate the adapters in each rotor so the timing marks are phased 180 degrees apart with the hex bores aligned.

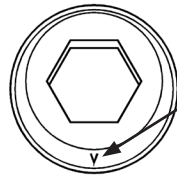

TIMING MARK FOR PHASING BEARING ADAPTERS IN THE ROTOR SHAFT ASSEMBLY

2. Use a marker pen to assist with aligning timing marks between rotors. Mark two rotor shaft flats 180 degrees apart next to the threaded end. The marked flats must align with the timing marks of any rotors not removed during servicing.

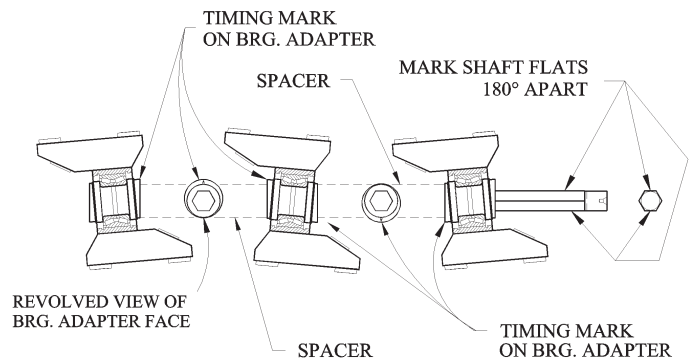



# SERVICE

- Install the required components in the sequence shown below. Double-check the timing mark location and the spacer lengths (refer to table) as each rotor is installed.

Spacer	Length	Part Number
A	3-51/64" (96.4 mm)	80.0337
B	7-1/4" (184.2 mm)	80.0338
C	3-9/16" (90.5 mm)	80.0339
D	3-19/64" (83.7 mm)	80.0340

NOTE: PLACE (4) 3/8 x 1" GD 5 CARRIAGE BOLTS THRU THESE BRG. FLANGES (AS SHOWN) PRIOR TO ASSEMBLING PULLEY

VIEW FROM REAR OF MACHINE

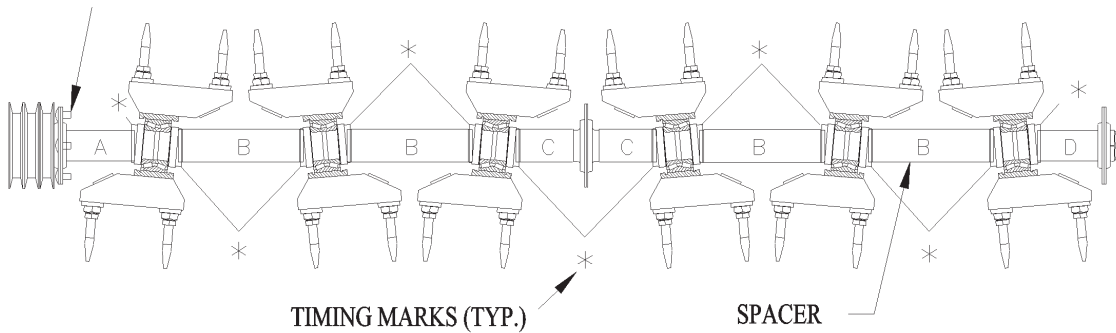

## Attention

Spacers must be fully seated in each adapter counter bore before tightening. Make sure bearing stampings are in place on the shaft bearings during reassembly. The 3/8" carriage bolts on the drive end bearing flange must be in place before the drive pulley is reinstalled.

- Replace the 1-1/8" hex jam nut and rotate each rotor occasionally as the nut is torqued to 350 ft-lbs (475 Nm). If any rotor locks up, the bearing adapters in the rotor are probably not phased 180 degrees apart, or the spacers are not fully seated.

# SERVICE

## Rotor Shaft Installation

1. Use a hoist to lift the AERA-vator frame and position it above the rotor shaft.
2. Carefully lower the AERA-vator into place while keeping the frame far enough away from the bearing flanges that the carriage bolts in the pulley end can clear the frame.
3. When the holes in the AERA-vator frame align with the carriage bolts, move the unit toward the bearing flange until the bolts are inserted through the frame end. Install the nuts onto the carriage bolts and hand tighten.
4. Install carriage bolts through the flanges in the idler end bearing and into the frame end. Install the nuts and hand tighten.
5. Install carriage bolts through the flanges in the center bearing and into the center bearing mount. Install the nuts and hand tighten.
6. Torque the nuts on all the bearing mount bolts to 31 ft-lbs (42 Nm).
7. Install the 3) drive belts onto the pulleys.
8. Install the belt retainer, making sure the belts will not rub on the retainer when tensioned. Torque bolts to 100 in-lbs (11 Nm).
9. Install the three belt shield and torque bolts to 100 in-lbs (11 Nm).
10. Attach the AERA-vator to a power unit. Run the AREA-vator to check for loose or improperly installed components.

## Tine Replacement

Assemble tines to rotor as shown below. Torque tines to 210 ft-lbs (285 Nm). NOTE: an extra deep 15/16" socket (Ventrac part # 72.0041) is available for removal and installation of tines.

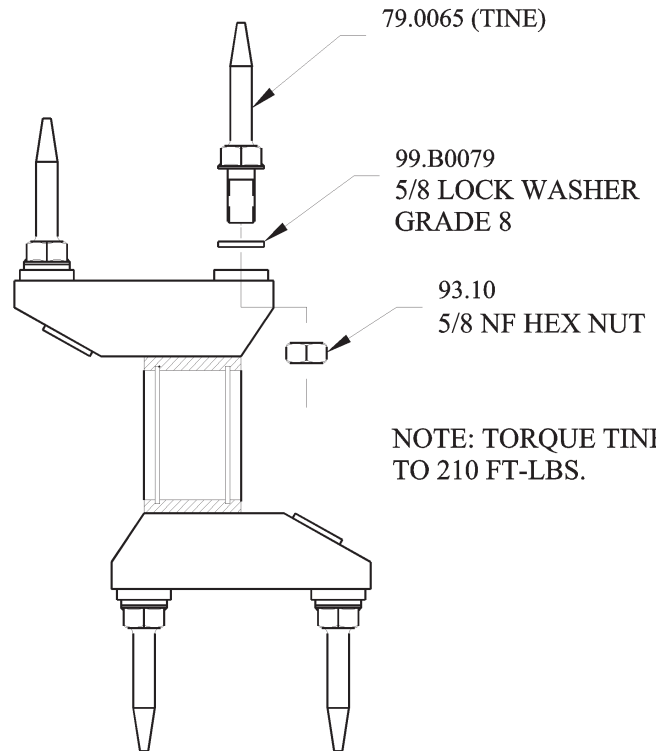

# SERVICE

## Maintenance Schedule

Maintenance Schedule	# of Locations	# of Pumps	Daily	At 50 Hours	At 100 Hours	At 150 Hours	At 200 Hours	At 250 Hours	At 300 Hours	At 350 Hours	At 400 Hours	At 450 Hours	At 500 Hours	At 550 Hours	At 600 Hours	At 650 Hours	At 700 Hours	At 750 Hours	At 800 Hours	At 850 Hours	At 900 Hours	At 950 Hours	At 1000 Hours	Yearly
				✓	✓	✓	✓	✓	✓	✓	✓	✓	✓	✓	✓	✓	✓	✓	✓	✓	✓	✓	✓	✓
Grease & Lubrication: See Lubrication Section																								
Drive Shaft Bearing	1	1		✓	✓	✓	✓	✓	✓	✓	✓	✓	✓	✓	✓	✓	✓	✓	✓	✓	✓	✓	✓	✓
Universal Joint	1	1		✓	✓	✓	✓	✓	✓	✓	✓	✓	✓	✓	✓	✓	✓	✓	✓	✓	✓	✓	✓	✓
Optional Rear Roller Bearings	2	1		✓	✓	✓	✓	✓	✓	✓	✓	✓	✓	✓	✓	✓	✓	✓	✓	✓	✓	✓	✓	✓
Optional Seeder Rotor Bearings	4		✓																					
Optional Seeder Drive Chain	1			✓	✓	✓	✓	✓	✓	✓	✓	✓	✓	✓	✓	✓	✓	✓	✓	✓	✓	✓	✓	✓
Check Gearbox Oil Level				✓	✓	✓	✓	✓	✓	✓	✓	✓	✓	✓	✓	✓	✓	✓	✓	✓	✓	✓	✓	✓
Change Gearbox Oil. Replace w/ 80-90 Weight Synthetic Gear Oil			✓										✓											✓
Inspection																								
Inspect for Loose, Missing, or Worn Components.			✓																					
Inspect Drive Belts			✓																					
Inspect AERA-vator Tines			✓																					
Inspect Safety Decals			✓																					
Inspect Seeder Drive Chain Tension				✓	✓	✓	✓	✓	✓	✓	✓	✓	✓	✓	✓	✓	✓	✓	✓	✓	✓	✓	✓	✓

## Maintenance Checklist

Maintenance Checklist	# of Locations	# of Pumps	At 50 Hours	At 100 Hours	At 150 Hours	At 200 Hours	At 250 Hours	At 300 Hours	At 350 Hours	At 400 Hours	At 450 Hours	At 500 Hours	At 550 Hours	At 600 Hours	At 650 Hours	At 700 Hours	At 750 Hours	At 800 Hours	At 850 Hours	At 900 Hours	At 950 Hours	At 1000 Hours	Yearly	
Grease & Lubrication: See Lubrication Section																								
Drive Shaft Bearing	1	1																						
Universal Joint	1	1																						
Optional Rear Roller Bearings	2	1																						
Optional Seeder Rotor Bearings	4																							
Optional Seeder Drive Chain	1																							
Check Gearbox Oil Level																								
Change Gearbox Oil. Replace w/ 80-90 Weight Synthetic Gear Oil																								
Inspection																								
Inspect for Loose, Missing, or Worn Components.																								
Inspect Drive Belts																								
Inspect for Damaged Tiller Tines																								
Inspect Safety Decals																								
Inspect Seeder Drive Chain Tension																								

# SPECIFICATIONS

---

## Dimensions

Overall Height . . . . .	22 inches (56 cm)
Overall Height with Optional Seeder . . . . .	32 inches (81.5 cm)
Overall Length . . . . .	34 inches (86.5 cm)
Overall Width . . . . .	66 inches (167.5 cm)
Overall Width with Optional Seeder . . . . .	67-1/2 inches (171.5 cm)
Working Width . . . . .	60 inches (152.5 cm)
Weight . . . . .	420 pounds (190 kg)
Weight with Optional Seeder . . . . .	525 pounds (238 kg)
Tines . . . . .	9/16 x 3-1/2 inches (14.3 x 89 mm)
Vibration Depth . . . . .	2-3/4 inches (7 cm)
Aeration Density - 16 Tine Rotor (Serial # 1001-1139) . . . . .	6 holes / ft <sup>2</sup> (65 holes / m <sup>2</sup> )
Aeration Density - 24 Tine Rotor (Serial # 1140-) . . . . .	8 holes / ft <sup>2</sup> (86 holes / m <sup>2</sup> )
Shaft Speed . . . . .	800 cycles per minute
Optimal Engine Speed. . . . .	3,200 RPM
RPM - Optional Seeder . . . . .	15 (rotor); 30 (motor)
Seeder Hopper Capacity . . . . .	2.5 ft <sup>3</sup> (.07 m <sup>3</sup> )

## Features

- Jack stand for ease of attachment
- Weight mounting bar holds up to 8) Ventrac weights
- Ventrac mount system
- Optional seeder kit
- Optional rear roller kit

# WARRANTY



## LIMITED WARRANTY - VENTRAC COMMERCIAL EQUIPMENT

Venture Products, Inc., (henceforth referred to as V.P.I.) warrants on the terms and conditions herein, that it will repair, replace, or adjust any part manufactured by Venture Products Inc., and found by Venture Products, Inc., to be defective in material and/or workmanship during the applicable warranty term.

All Ventrac commercial equipment purchased and registered on or after January 1, 2019 will carry a 2-year commercial warranty. The warranty period begins on the date of original customer purchase:

<b>Ventrac Commercial Equipment</b>	<b>Warranty Term</b>
2100 SSV & Attachments	2-year
3000 Series Tractors & Attachments	2-year
4000 Series Tractors & Attachments	2-year

All Ventrac add-on kits and accessories such as: 3-point hitch, 12V front & rear power outlets, foot pedal, dual wheel kit, etc., will be covered under the above warranty periods provided they are installed by an Authorized Ventrac Dealer. This warranty may be transferred and will carry the remainder of the warranty starting from the original purchase/registration date with the dealership and/or V.P.I.

The engine warranty is covered by its respective engine manufacturer. Please refer to the engine manufacturer's warranty statement that is included in the owner's manual.

For warranty consideration on Ventrac commercial equipment, including any defective part, must be returned to an Authorized Ventrac Dealer within the warranty period. The warranty shall extend to the cost to repair or replace (as determined by V.P.I.) the defective part. The expense of pickup and delivery of equipment, service call drive time or any transportation expense incurred for warranty repair is the sole responsibility of the owner and is not covered under warranty by Ventrac and/or V.P.I. Ventrac and V.P.I.'s responsibility in respect to claims is limited to making the required repairs or replacements, and no claim of breach of warranty shall be cause for cancellation or rescission of the contract of sale of any Ventrac equipment. Proof of purchase may be required by the dealer to substantiate any warranty claim. Only warranty work performed and submitted by an Authorized Ventrac Dealer may be eligible for warranty credit.

This warranty extends only to Ventrac commercial equipment operated under normal conditions and properly serviced and maintained. The warranty expressly does NOT cover: (a) any defects, damage or deterioration due to normal use, wear and tear, or exposure; (b) normal maintenance services, such as cleaning, lubrication, oil change; (c) replacement of service items, such as oil, lubricants, spark plugs, belts, rubber hoses, bearings or other items subject to normal service replacement; (d) damage or defects arising out of, or relating to abuse, misuse, neglect, alteration, negligence or accident; (e) repair or replacement arising from operation of, or use of the equipment which is not in accordance with operating instructions as specified in the operator's manual or other operational instructions provided by V.P.I.; (f) repair or replacement arising as a result of any operation from Ventrac equipment that has been altered or modified so as to, in the determination of V.P.I., adversely affect the operation, performance or durability of the equipment or that has altered, modified or affected the equipment so as to change the intended use of the product; (g) repair or replacement necessitated by the use of parts, accessories or supplies, including gasoline, oil or lubricants, incompatible with the equipment or other than as recommended in the operator's manual or other operational instructions provided by V.P.I.; (h) repairs or replacements resulting from parts or accessories which have adversely affected the operation, performance or durability of the equipment; or (i) damage or defects due to or arising out of repair of Ventrac equipment by person or persons other than an authorized Ventrac service dealer or the installation of parts other than genuine Ventrac parts or Ventrac recommended parts.

# WARRANTY

---



## LIMITED WARRANTY - VENTRAC COMMERCIAL EQUIPMENT

The sole liability of V.P.I. with respect to this warranty shall be the repair and replacement as set forth herein. V.P.I. shall have no liability for any other cost, loss, or damage. In particular V.P.I. shall have no liability or responsibility for: (i) expenses relating to gasoline, oil, lubricants; (ii) loss, cost or expense relating to transportation or delivery of turf equipment from the location of owner or location where used by owner to or from any Authorized Ventrac Dealer; (iii) travel time, overtime, after hours' time or other extraordinary repair charges or charge relating to repairs or replacements outside of normal business hours at the place of business of an Authorized Ventrac Dealer; (iv) rental of like or similar replacement equipment during the period of any warranty repair or replacement work; (v) any telephone or telegram charges; (vi) loss or damage to person or property other than that covered by the terms of this warranty; (vii) any claims for lost revenue, lost profit or additional cost or expense incurred as a result of a claim of breach of warranty; or (viii) attorney's fees.

The remedies of buyer set forth herein are exclusive and are in lieu of all other remedies. The liability of V.P.I., whether in contract, tort, under any warranty, or otherwise, shall not extend beyond its obligation as set forth herein. V.P.I. shall not be liable for cost of removal or installation nor shall V.P.I. be responsible for any direct, indirect, special or consequential damages of any nature. In no event shall V.P.I. be liable for any sum in excess of the price received for the goods for which liability is claimed.

There are no representations or warranties which have been authorized to the buyer of the Ventrac commercial equipment other than set forth in this warranty. Any and all statements or representations made by any seller of this equipment, including those set forth in any sales literature or made orally by any sales representative, are superseded by the terms of this warranty. Any affirmation of fact or promise made by V.P.I. or any of its representatives to the buyer which relates to the goods that are the subject to this warranty shall not be regarded as part of the basis of the bargain and shall not be deemed to create any express warranty that such goods shall conform to the affirmation or promise.

No employee, distributor, or representative is authorized to change the foregoing warranties in any way or grant any other warranty on behalf of V.P.I.

Some states do not allow limitations on how long an implied warranty lasts or allow the exclusion on limitation of incidental or consequential damages, so the above limitation or exclusion may not apply to you.

This warranty gives you specific legal rights, and you may also have other rights which vary from state to state.

This warranty applies to all Ventrac commercial equipment sold by Venture Products Inc.