

*Operator's Manual
& Parts Drawings*

KX523

Snow Blower
Europe C€





500 Venture Drive
Orrville Oh 44667
www.ventrac.com

View all manuals



Visit ventrac.com/manuals for the latest version of this operator's manual.

A downloadable parts manual is also available.

To the Owner Contact Information and Product Identification

If you need to contact an authorized Ventrac dealer for information on servicing your product, always provide the product model and serial numbers.

Please fill in the following information for future reference. See the picture(s) below to find the location of the identification numbers. Record them in the spaces provided.

Date of Purchase: _____

Dealer: _____

Dealer Address: _____

Dealer Phone Number: _____

Dealer Fax Number: _____

Model # (A): _____

Serial # (B): _____

Affix Part/Serial Number label here.

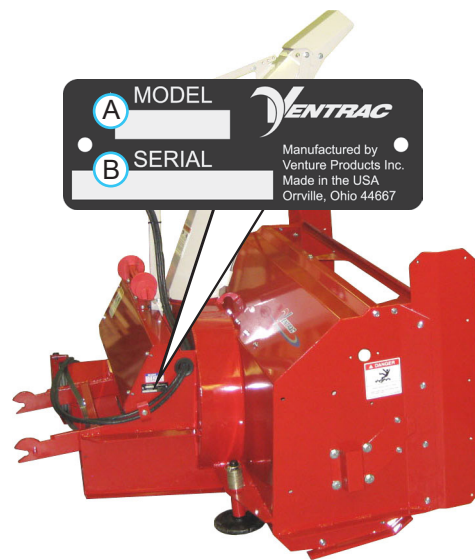

Venture Products Inc. reserves the right to make changes in design or specifications without obligation to make like changes on previously manufactured products.

TABLE OF CONTENTS

INTRODUCTION	PAGE 5
Product Description.....	5
Why Do I Need an Operator’s Manual?	5
Using Your Manual	6
Manual Glossary	6
SAFETY	PAGE 7
Safety Decals	7
General Safety Procedures.....	9
Training Required.....	9
Personal Protective Equipment Requirements	9
Operation Safety	9
Preventing Accidents.....	10
Keep Riders Off.....	10
Operating On Slopes.....	11
Roadway Safety	11
Truck Or Trailer Transport	11
Maintenance.....	12
Fuel Safety	12
Hydraulic Safety	13
KX523 Snow Blower Safety Procedures.....	14
OPERATIONAL CONTROLS	PAGE 15
Discharge Chute Rotation (A).....	15
Discharge Chute Adjustment Link (B)	15
Optional Discharge Chute Deflector Actuator Control (C).....	15
GENERAL OPERATION	PAGE 16
Daily Inspection.....	16
Attaching	16
Detaching.....	16
Snow Blower Operating Procedure.....	16
Transport of Snow Blower.....	17
Discharge Chute Rotation	17
Discharge Chute Deflector Adjustment (Optional Actuator Control).....	17
Rear Skid Shoe Adjustment	17
Front Skid Shoe Adjustment.....	17
Clearing a Blockage	18

TABLE OF CONTENTS

SERVICE	PAGE 19
Cleaning & General Maintenance	19
Cutting Edge Reversal/Replacement.....	19
Skid Shoe Replacement.....	19
Vertical Cutting Edge Adjustment.....	19
Belt Inspection/Replacement	19
Gearbox Drive Belt Replacement.....	20
Auger Drive Belt Replacement.....	20
Deep Snow Auger Drive Belt Replacement	20
Belt Tension Adjustment.....	20
Lubrication Locations	21
Checking Gearbox Oil Level	21
Changing Gearbox Oil.....	21
Storage.....	22
Maintenance Schedule.....	23
Maintenance Checklist.....	23
SPECIFICATIONS	PAGE 24
Dimensions	24
Features	24
Noise Emissions.....	25
EC Declaration of Conformity.....	25
PARTS	PAGE 26
Main Frame & Auger	26
PTO Drive & Gearbox Drive.....	28
Gearbox & Auger Drive	30
Fan & Fan Shaft.....	32
Fan Drive.....	34
Discharge Chute	36
Discharge Chute Rotation Drive.....	38
Discharge Chute Guard & Cleaning Tool	40
Drive Shields	42
Skid Shoes, Cutting Edge, & Crossbar Guard	44
70.8025 12 Volt Actuator	46
70.8072 Deep Snow Auger Kit.....	48
WARRANTY	PAGE 50

INTRODUCTION



Venture Products Inc. is pleased to provide you with your new Ventrac snow blower! We hope that Ventrac equipment will provide you with a ONE Tractor Solution.

Listed below are just some of the items that can provide you *versatility* as you use your snow blower. Please visit our web site, or contact your authorized Ventrac dealer for a complete list of items available for your new snow blower.

KX523 Accessories	Item Description	Part Number
	12 Volt Actuator Kit*	70.8025
	Deep Snow Top Auger Kit	70.8072

*Power unit must be equipped with a 12 volt front switch & plug.

Power Unit Accessories	Item Description	Part Number
	12 Volt Switch & Plug Kit (HT4000)	70.4046
	12 Volt Switch & Plug Kit (KT4100 & KT4200)	70.4039
	12 Volt Switch & Plug Kit (KN4500)	70.4104
	Weight Transfer Kit for KT4100	70.0104
Weight Transfer Kit for KN4500K	70.4115	

Product Description

The Ventrac Model KX523 Snow Blower is designed for the sole purpose of blowing snow. It is a powerful, high capacity, two stage snow blower that moves large amounts of snow quickly.

The snow blower's large 16" (40.6 cm) auger funnels the snow into the high speed fan which throws the snow up to 40 feet (12.2 m) away from the operation area.

The discharge chute is hydraulically controlled. The operator controls the direction of the discharge from the operator's seat of the power unit.

An optional 12 volt actuator kit (70.8025) can be purchased to allow the operator to control the throw distance of the snow blower from the operator's seat of the power unit.

For areas with heavy snowfall, an optional deep snow (top auger) kit (70.8072) is available. The deep snow kit mounts a small auger above the main auger for effective removal of deeper snow.

Why Do I Need an Operator's Manual?

This manual has been created to help you gain the important knowledge of what is needed to safely operate, maintain, and service your machine. It is divided into sections for convenient reference of the appropriate section.

You must read and understand the operator's manual for each piece of Ventrac equipment you own. Reading the operator's manual will help you become familiar with each specific piece of equipment. Understanding the operator's manual will help you, as well as others, avoid personal injury and/or damage to the equipment. Keep this manual with the machine at all times. The manual should remain with the machine even if it is sold. If this manual becomes damaged or unreadable, it should be replaced immediately. Contact your local Ventrac dealer for a replacement.

When using a Ventrac attachment, be sure to read and follow the safety and operating instructions of both the power unit and the attachment being used to ensure the safest operation possible.

The information in this manual provides the operator with the safest procedures to operate the machine while getting the maximum use out of the unit. Failure to follow the safety precautions listed in this manual may result in personal injury and/or damage to the equipment.

INTRODUCTION

Using Your Manual

Throughout this manual, you will encounter special messages and symbols that identify potential safety concerns to help you as well as others avoid personal injury or damage to the equipment.

SYMBOL DEFINITIONS



ATTENTION

This symbol identifies potential health and safety hazards. It marks safety precautions. Your safety and the safety of others is involved.

There are three signal words that describe the level of safety concern: Danger, Warning, and Caution. Safety should always be the #1 priority when working on or operating equipment. Accidents are more likely to occur when proper operating procedures are not followed or inexperienced operators are involved.

Note: Right-Hand and Left-Hand orientations may be referred to at different places throughout this manual. Right-Hand and Left-Hand is determined as if sitting on the tractor seat facing forward.

SIGNAL WORD DEFINITIONS

⚠ DANGER

Indicates an imminently hazardous situation which, if not avoided, will result in death or serious injury. This signal word is limited to the most extreme cases.

⚠ WARNING

Indicates a potentially hazardous situation which, if not avoided, could result in death or serious injury.

⚠ CAUTION

Indicates a potentially hazardous situation which, if not avoided, may result in minor or moderate injury and/or property damage. It may also be used to alert against unsafe practices.

Manual Glossary

- Power Unit** A Ventrac tractor or other Ventrac engine powered device that may be operated by itself or with an attachment or accessory.
- Attachment** A piece of Ventrac equipment that requires a Power Unit for operation.
- Accessory** A device that attaches to a Power Unit or Attachment to extend its capabilities.
- Machine** Describes any "Attachment" or "Accessory" that is used in conjunction with a power unit. This term is used when referring to both at the same time.

SAFETY

Safety Decals

The following safety decals must be maintained on your KX523 Snow Blower.

Keep all safety decals legible. Remove all grease dirt, and debris from safety decals and instructional labels. If any decals are faded, illegible, or missing, contact your dealer promptly for replacements.

When new components are installed, be sure that current safety decals are affixed to the replacement components.

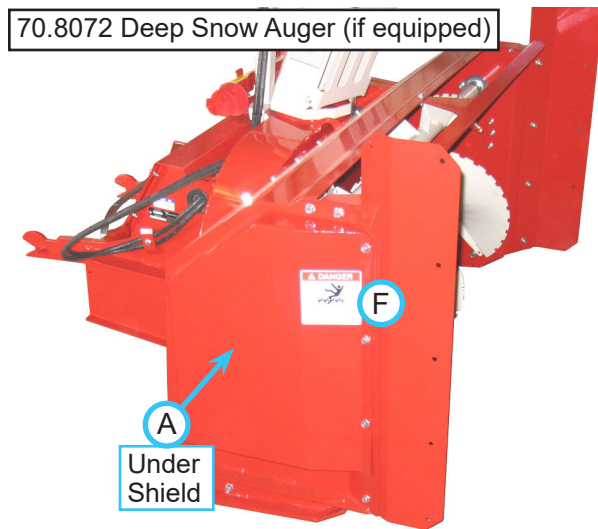
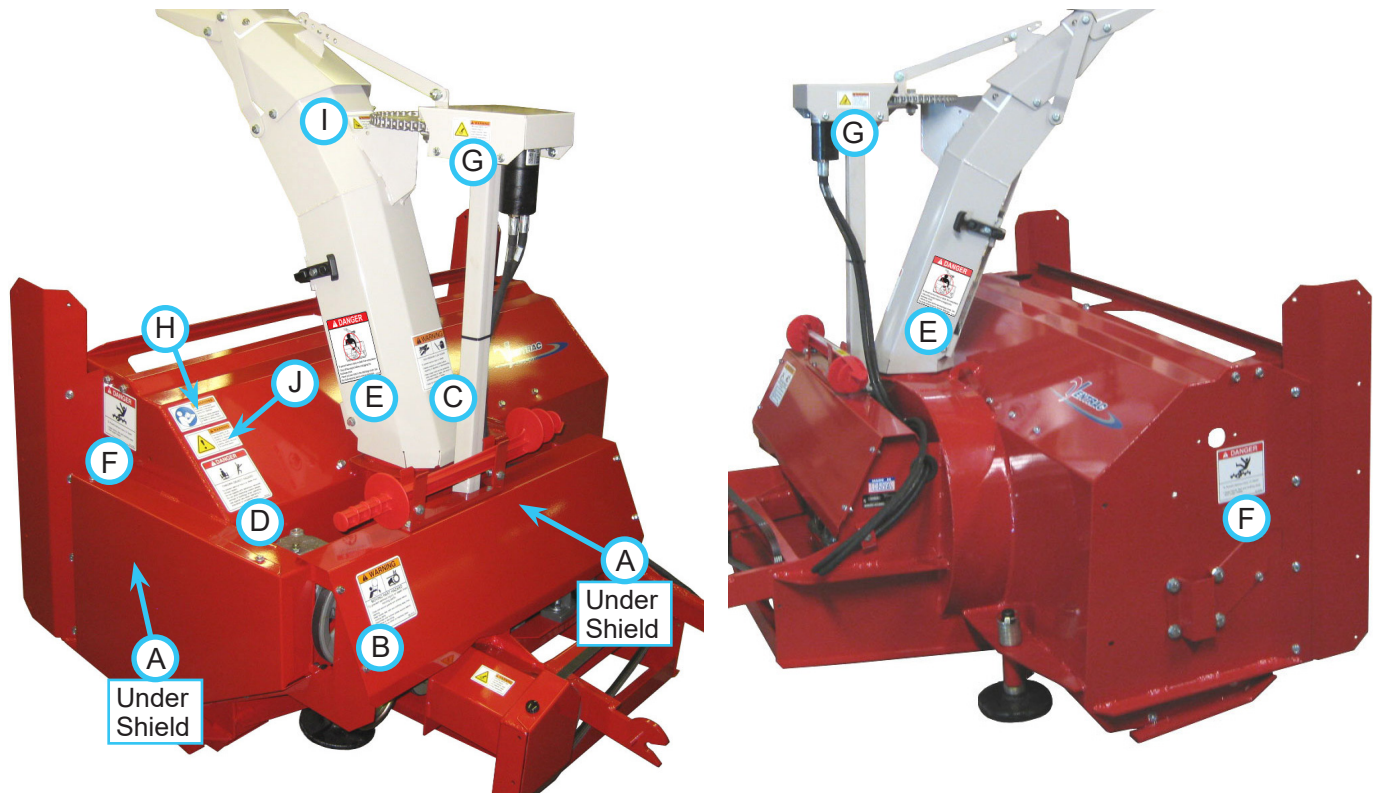

SAFETY

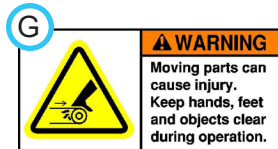
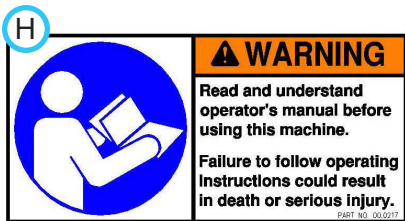
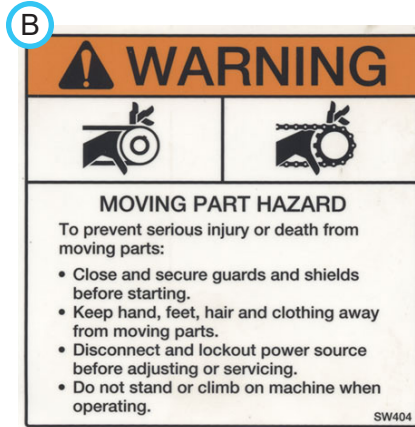

Decal	Description	Part Number	Quantity
A	Danger, Shield Missing	00.0062	2 (3)
B	Warning - Moving Part Hazard	00.0101	1
C	Warning, High Pressure Fluid	00.0103	1
D	Danger, Thrown Object Hazard	00.0122	1
E	Danger, Discharge Chute Safety	00.0409	2
F	Danger, Auger Hazard	00.0208	2 (3)
G	Warning, Moving Parts	00.0216	3
H	Warning, Read Owner's Manual	00.0217	1
I	Warning, Pinch Point	00.0218	1
J	Warning, General Safety	00.0220	1

SAFETY



General Safety Procedures for Ventrac Power Units, Attachments, & Accessories



Training Required

- The owner of this machine is solely responsible for properly training the operators.
- The owner/operator is solely responsible for the operation of this machine and prevention of accidents or injuries occurring to him/herself, other people, or property.
- Do not allow operation or service by children or untrained personnel. Local regulations may restrict the age of the operator.
- Before operating this machine, read the operator's manual and understand its contents.
- If the operator of the machine cannot understand this manual, then it is the responsibility of this machine's owner to fully explain the material within this manual to the operator.
- Learn and understand the use of all controls.
- Know how to stop the power unit and all attachments quickly in the event of an emergency.



Personal Protective Equipment Requirements

It is the responsibility of the owner to be sure that the operators use the proper personal protective equipment while operating the machine. Required personal protective equipment includes, but is not limited to, the following list.



- Wear a certified ear protection device to prevent loss of hearing.
- Prevent eye injury by wearing safety glasses while operating the machine.
- Closed toe shoes must be worn at all times.
- Long pants must be worn at all times.
- When operating in dusty conditions, it is recommended that a dust mask be worn.

Operation Safety

- Inspect machine before operation. Repair or replace any damaged, worn, or missing parts. Be sure guards and shields are in proper working condition and are secured in place. Make all necessary adjustments before operating machine.
- Some pictures in this manual may show shields or covers opened or removed in order to clearly illustrate any instructions. Under no circumstance should the machine be operated without these devices in place.
- Alterations or modifications to this machine can reduce safety and could cause damage to the machine. Do not alter safety devices or operate with shields or covers removed.
- Before each use, verify that all controls function properly and inspect all safety devices. Do not operate if controls or safety devices are not in proper working condition.
- Check parking brake function before operating. Repair or adjust parking brake if necessary.
- Observe and follow all safety decals.
- All controls are to be operated from the operator's station only.
- Always wear a seat belt if the machine has a roll cage/bar installed and in upright position.
- Ensure the attachment or accessory is locked or fastened securely to the power unit before operating.
- Ensure that all bystanders are clear of the power unit and attachment before operating. Stop machine if someone enters your work area.
- Always be alert to what is happening around you, but do not lose focus on the task you are performing. Always look in the direction the machine is moving.
- Look behind and down before backing up to be sure of a clear path.
- If you hit an object, stop and inspect the machine. Make all necessary repairs before operating machine again.
- Stop operation immediately at any sign of equipment failure. An unusual noise can be a warning of equipment failure or a sign that maintenance is required. Make all necessary repairs before operating machine again.

SAFETY



General Safety Procedures for Ventrac Power Units, Attachments, & Accessories



Operation Safety (continued)

- If equipped with a high/low range feature, never shift between high and low range while on a slope. Always move the machine to level ground and engage the parking brake before shifting range.
- Do not leave machine unattended while it is running.
- Always park the machine on level ground.
- Always shut off engine when connecting attachment drive belt to the power unit.
- Never leave the operator's station without lowering the attachment to the ground, setting the parking brake, shutting off the engine, and removing the ignition key. Make sure all moving parts have come to a complete stop before dismounting.
- Never leave equipment unattended without lowering the attachment to the ground, setting the parking brake, shutting off the engine, and removing the ignition key.
- Only operate in well-lit conditions.
- Do not operate when there is a risk of lightning.
- Never direct the discharge of any attachment in the direction of people, buildings, animals, vehicles, or other objects of value.
- Never discharge material against a wall or obstruction. Material may ricochet back towards the operator.
- Use extra caution when approaching blind corners, shrubs, trees, or other objects that may obscure vision.
- Do not run the engine in a building without adequate ventilation.
- Do not touch the engine or the muffler while the engine is running or immediately after stopping the engine. These areas may be hot enough to cause a burn.
- Do not change the engine governor settings or over-speed the engine. Operating engine at excessive speed may increase the hazard of personal injury.
- To reduce the hazard of fire, keep the battery compartment, engine, and muffler areas free of grass, leaves, excessive grease, and other flammable materials.

Preventing Accidents



- Clear working area of objects that might be hit or thrown from machine.
- Keep people and pets out of working area.
- Know the work area well before operation. Do not operate where traction or stability is questionable.
- Reduce speed when you are operating over rough ground.
- Equipment can cause serious injury and/or death when improperly used. Before operating, know and understand the operation and safety of the power unit and the attachment being used.

- Do not operate machine if you are not in good physical and mental health, if you will be distracted by personal devices, or are under the influence of any substance which might impair decision, dexterity, or judgment.
- Children are attracted to machine activity. Be aware of children and do not allow them in the working area. Turn off the machine if a child enters the work area.

Keep Riders Off

- Only allow the operator on the power unit. Keep riders off.
- Never allow riders on any attachment or accessory.



SAFETY



General Safety Procedures for Ventrac Power Units, Attachments, & Accessories



Operating On Slopes

- Slopes can cause loss-of-control and tip-over accidents, which can result in severe injury or death. Be familiar with the emergency parking brake, along with the power unit controls and their functions.
- If power unit is equipped with a fold down roll bar, it must be locked in the upright position when operating on any slope.
- Use low range (if equipped) when operating on slopes greater than 15 degrees.
- Do not stop or start suddenly when operating on slopes.
- Never shift between high and low range while on a slope. Always move the power unit to level ground and engage the parking brake before shifting range or placing the power unit in neutral.
- Variables such as wet surface and loose ground will reduce the degree of safety. Do not drive where machine could lose traction or tip over.
- Keep alert for hidden hazards in the terrain.
- Stay away from drop-offs, ditches, and embankments.
- Sharp turns should be avoided when operating on slopes.
- Pulling loads on hills decreases safety. It is the responsibility of the owner/operator to determine loads that can safely be controlled on slopes.
- Transport machine with attachment lowered or close to the ground to improve stability.
- While operating on slopes, drive in an up and down direction when possible. If turning is necessary while driving across slopes, reduce speed and turn slowly in the downhill direction.
- Assure a sufficient supply of fuel for continuous operation. A minimum of one-half tank of fuel is recommended.

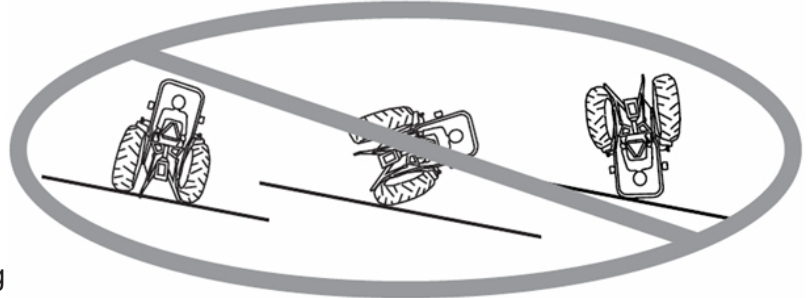

Roadway Safety

- Operate with safety lights when operating on or near roadways.
- Obey all state and local laws concerning operation on roadways.
- Slow down and be careful of traffic when operating near or crossing roadways. Stop before crossing roads or sidewalks. Use care when approaching areas or objects that may obscure vision.
- If there is doubt of safety conditions, discontinue machine operation until a time when operation can be performed safely.
- When operating near or on roadways, have a Slow Moving Vehicle Emblem clearly displayed.

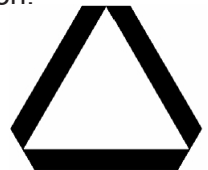

Truck Or Trailer Transport

- Use care when loading or unloading machine into a truck or trailer.
- Use full width ramps for loading machine into a truck or trailer.
- The parking brake is not sufficient to lock the machine during transport. Always secure the power unit and/or attachment to the transporting vehicle securely using straps, chains, cable, or ropes. Both front and rear straps should be directed down and outward from the machine.
- Shut off fuel supply to power unit during transport on truck or trailer.
- If equipped, turn the battery disconnect switch to the Off position to shut off electrical power.

SAFETY



General Safety Procedures for Ventrac Power Units, Attachments, & Accessories



Maintenance

- Keep all safety decals legible. Remove all grease dirt, and debris from safety decals and instructional labels.
- If any decals are faded, illegible, or missing, contact your dealer promptly for replacements.
- When new components are installed, be sure that current safety decals are affixed to the replacement components.
- If any component requires replacement, use only original Ventrac replacement parts.
- Always turn the battery disconnect to the Off position or disconnect the battery before performing any repairs. Disconnect the negative terminal first and the positive terminal last. Reconnect the positive terminal first and the negative terminal last.
- Keep all bolts, nuts, screws, and other fasteners properly tightened.
- Always lower the attachment to the ground, engage parking brake, shut off engine, and remove the ignition key. Make sure all moving parts have come to a complete stop before cleaning, inspection, adjusting or repairing.
- If the power unit, attachment, or accessory requires repairs or adjustments not instructed in the operator's manual, the power unit, attachment, or accessory must be taken to an authorized Ventrac dealer for service.
- Never perform maintenance on the power unit and/or attachment if someone is in the operator's station.
- Always use protective glasses when handling the battery.
- Check all fuel lines for tightness and wear on a regular basis. Tighten or repair them as needed.
- To reduce the hazard of fire, keep the battery compartment, engine, and muffler areas free of grass, leaves, and excessive grease.
- Do not touch the engine, the muffler, or other exhaust components while the engine is running or immediately after stopping the engine. These areas may be hot enough to cause a burn.
- Allow the engine to cool before storing and do not store near an open flame.
- Do not change the engine governor settings or over-speed the engine. Operating engine at excessive speed may increase the hazard of personal injury.
- Springs may contain stored energy. Use caution when disengaging or removing springs and/or spring loaded components.
- An obstruction or blockage in a drive system or moving/rotating parts may cause a buildup of stored energy. When the obstruction or blockage is removed, the drive system or moving/rotating parts may move suddenly. Do not attempt to remove an obstruction or blockage with your hands. Keep hands, feet, and clothing away from all power-driven parts.
- Dispose of all fluids in accordance with local laws.

Fuel Safety



- To avoid personal injury or property damage, use extreme care in handling gasoline. Gasoline is extremely flammable and the vapors are explosive.
- Do not refuel machine while smoking or at a location near flames or sparks.
- Always refuel the machine outdoors.
- Do not store machine or fuel container indoors where fumes or fuel can reach an open flame, spark, or pilot light.
- Only store fuel in an approved container. Keep out of reach of children.
- Never fill containers inside a vehicle or on a truck or trailer bed with a plastic liner. Always place containers on the ground away from your vehicle before filling.
- Remove machine from the truck or trailer and refuel it on the ground. If this is not possible, refuel the machine using a portable container, rather than from a fuel dispenser nozzle.
- Never remove fuel cap or add fuel with the engine running. Allow engine to cool before refueling.
- Never remove fuel cap while on a slope. Only remove when parked on a level surface.
- Replace all fuel tank and container caps securely.

SAFETY



General Safety Procedures for Ventrac Power Units, Attachments, & Accessories



Fuel Safety (continued)

- Do not overfill fuel tank. Only fill to bottom of fuel neck, do not fill fuel neck full. Overfilling of fuel tank could result in engine flooding, fuel leakage from the tank, and/or damage to the emissions control system.
- If fuel is spilled, do not attempt to start the engine. Move the power unit away from the fuel spill and avoid creating any source of ignition until fuel vapors have dissipated.
- If the fuel tank must be drained, it should be drained outdoors into an approved container.
- Dispose of all fluids in accordance with local laws.
- Check all fuel lines for tightness and wear on a regular basis. Tighten or repair them as needed.
- The fuel system is equipped with a shut-off valve. Shut off the fuel when transporting the machine to and from the job, when parking the machine indoors, or when servicing the fuel system.

Hydraulic Safety

- Make sure all hydraulic connections are tight and all hydraulic hoses and tubes are in good condition. Repair any leaks and replace any damaged or deteriorated hoses or tubes before starting the machine.
- Hydraulic leaks can occur under high pressure. Hydraulic leaks require special care and attention.
- Use a piece of cardboard and a magnifying glass to locate suspected hydraulic leaks.



- Keep body and hands away from pinhole leaks or nozzles that eject high pressure hydraulic fluid. Hydraulic fluid escaping under high pressure can penetrate the skin causing serious injury, leading to severe complications and/or secondary infections if left untreated. If hydraulic fluid is injected into the skin, seek immediate medical attention no matter how minor the injury appears.

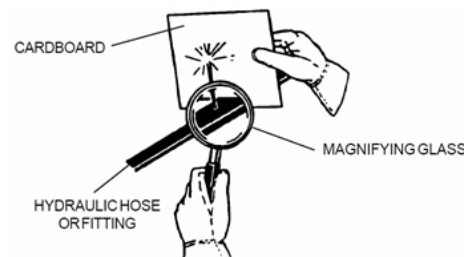

- Hydraulic system may contain stored energy. Before performing maintenance or repairs on the hydraulic system, remove attachments, engage parking brake, disengage weight transfer system (if equipped), shut off engine, and remove ignition key. To relieve pressure on the auxiliary hydraulic system, shut off the power unit engine and move the hydraulic control lever left and right before disconnecting the auxiliary hydraulic quick couplers.
- Dispose of all fluids in accordance with local laws.

SAFETY



KX523 Snow Blower Safety Procedures



- This snow blower is capable of amputating hands and feet and throwing objects. Failure to observe the following safety instructions could result in serious injury.
- Read and understand the KX523 snow blower operator's manual before operating the snow blower.
- Before making repairs or adjustments to the snow blower, engage the power unit's parking brake, lower the snow blower to the ground, shut off the power unit's engine, and remove the ignition key.
- Always block up the snow blower securely when adjusting the skid shoes.
- The snow blower housing is open in the front due to its functionality, thus exposing the auger. When operating, EXTREME care should be used when approaching a stationary object such as a tree or a pole.
- Do not put hands or feet near or under rotating parts. Keep clear of the discharge opening at all times.
- Never direct the snow blower discharge chute in the direction of people, buildings, animals, vehicles, or other objects of value. Debris can be thrown from the chute causing damage, serious injury, or death.
- Never operate the snow blower when people are in the area. Frozen snow, ice, gravel, and other objects can be thrown at lethal velocity.
- Operators should be familiar with the area they are clearing and make preparations ahead of time. Place guide stakes appropriately and remove stones, markers, or other debris that may be hidden after a snowfall. Curbs, offsets, steps, man hole covers, broken or raised pavement, etc. should be noted. Operators should map areas to be cleared before the winter season so they can review potential hazards prior to clearing snow in the area.
- If an area is to be cleared that is unfamiliar to the operator, travel slowly and use EXTREME CAUTION. Inquire of anyone who might know of potential hazards.
- Discharge snow with the wind direction as much as possible. Discharging into the wind reduces blowing distance and visibility.
- The operator should never proceed if visibility is poor. If the tractor is equipped with a cab, the windshield must be kept clean.
- Use caution when operating around objects that can obstruct your vision.
- Never travel at speeds that would cause injury to the operator or damage to the machine if the machine were to be stopped suddenly by an unseen, immovable object.
- Never operate at high transport speeds on slippery surfaces.
- No one other than the operator should ever attempt to clear the discharge opening in the event of a blockage. Lower the snow blower to the ground, set the power unit's parking brake, shut off the power unit's engine, and remove the ignition key before any attempt is made to clear the blockage.
- Hand contact with the rotating fan inside the discharge chute is the most common cause of injury associated with snow blowers. Never use your hand to clean out the discharge chute. Use the provided chute cleaning tool to clear blockages.
- If the chute guard has been opened to clear a blockage, it must be closed and fastened before resuming operation.
- Do not operate the equipment without wearing adequate winter garments. Avoid loose fitting clothing that can get caught in moving parts. Wear footwear that will improve footing on slippery surfaces.
- Shut off the power unit's PTO when not blowing snow.
- Always shut off the power unit's PTO and engage the parking brake before dismounting to change the angle of the discharge chute deflector.
- Attachment hydraulic system may contain stored energy. Before performing maintenance or repairs on the hydraulic system, the attachment's auxiliary hydraulic hoses must be disconnected from the power unit. Lower the attachment to the ground, shut off power unit engine, move the secondary S.D.L.A. lever left and right to relieve auxiliary hydraulic pressure, and disconnect the auxiliary hydraulic quick couplers.

OPERATIONAL CONTROLS

Operational Control Locations

Use the following images to help identify the locations of operational controls. The letter next to each control can be referenced to the list that follows these images.

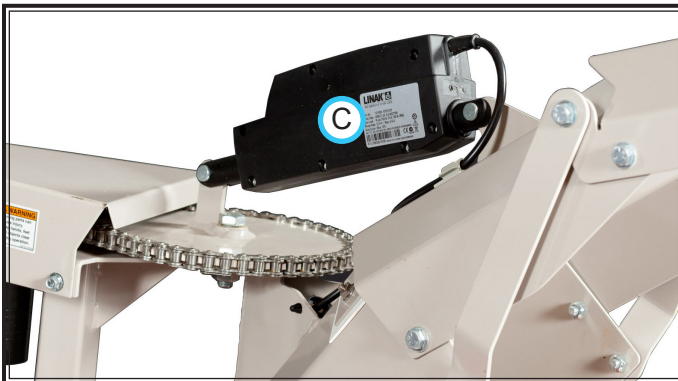
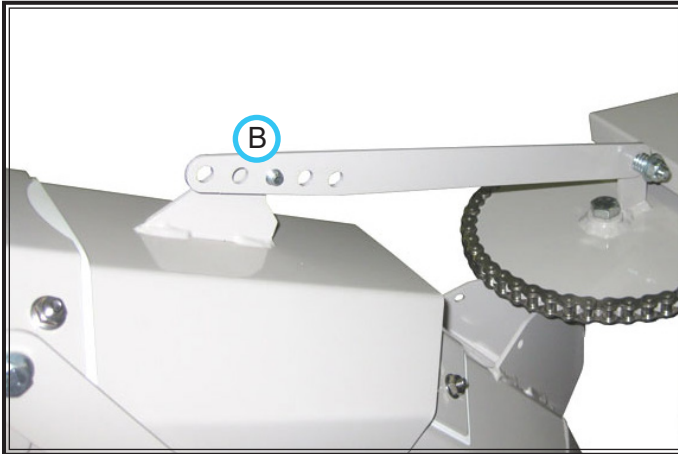
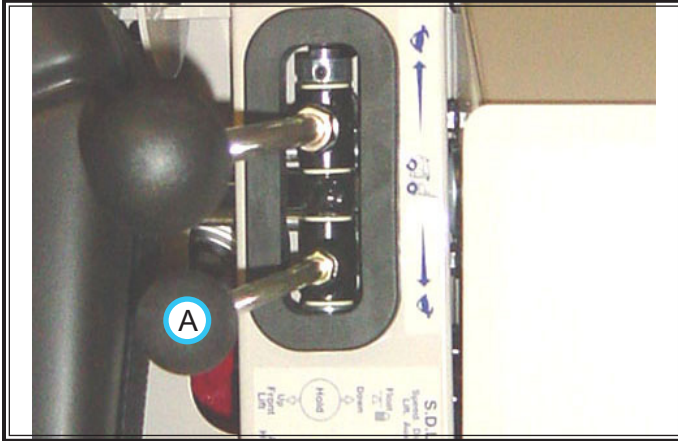

- A. Discharge Chute Rotation (Secondary S.D.L.A. Lever)
- B. Discharge Chute Adjustment Link
- C. Optional Discharge Chute Deflector Actuator Control

Discharge Chute Rotation (A) (Secondary S.D.L.A. Lever)

The secondary S.D.L.A. lever on the power unit controls the hydraulic rotation of the discharge chute. The discharge chute can be angled from left to right (180 degrees of rotation) to discharge snow in the desired direction.

Discharge Chute Adjustment Link (B)

The discharge chute adjustment link controls the angle of the discharge chute deflector. The angle of the discharge chute deflector determines the distance that snow is thrown.

Optional Discharge Chute Deflector Actuator Control (C)

This optional actuator replaces the discharge chute adjustment link on the snow blower. It couples with a 12 volt switch on the power unit, allowing the operator to control the angle of the discharge chute deflector from the operator's seat.

The actuator is controlled with an optional dash mounted momentary on toggle switch (D) on KT4100 and KT4200 models.



The actuator is controlled by momentary on switches (E) on the optional 12V front SDLA handle on KN4500 models.



GENERAL OPERATION

Daily Inspection

⚠ WARNING

Always set the parking brake, shut off power unit engine, remove the ignition key, and ensure all moving parts have come to a complete stop before inspecting components, or attempting any repair or adjustment.

1. Park machine on a level surface, with the engine shut off and all fluids cold.
2. Perform a visual inspection of both the power unit and the snow blower. Look for loose or missing hardware, damaged components, or signs of wear. Inspect hydraulic hoses, hydraulic fittings, and fuel lines to ensure tight, leak free connections. Inspect drive belts. Belts should be in good condition.
3. Refer to the power unit operator's manual. Check the power unit's engine oil, hydraulic oil, cooling system, tire pressure, and fuel level. Add fluid or service as required.
4. Inspect the cutting edge and skid shoes for wear and service as required.
5. Test the power unit's operator safety interlock system*.

Attaching

1. Drive the power unit slowly forward into the hitch arms of the snow blower. Align the lift arms of the power unit with the snow blower hitch arms by raising or lowering the front hitch and complete the engagement.
2. Once completely engaged, close the attachment hitch lock*.
3. Engage the parking brake* and shut off the power unit engine.
4. Place the attachment belt over the outside groove of the PTO drive pulley on the power unit. Ensure the belt is properly seated in each pulley.
5. Engage the PTO spring tension lever* on the power unit.
6. Wipe hose ends clean, and connect to the power unit's hydraulic quick couplers. Connect the hoses and quick couplers so the red indicators are paired together and the yellow indicators are paired together (if equipped).
7. Connect electric plug (if equipped).
8. Raise the snow blower to the highest position, then shut off power unit engine.
9. Engage the weight transfer system* (if equipped).

Detaching

1. Park the power unit on a level surface and set the parking brake*.
2. Raise the snow blower to the highest position, then shut off power unit engine.
3. Disengage the weight transfer system*.
4. Lower the snow blower to the ground.
5. Disengage the PTO spring tension lever*.
6. Remove the attachment belt from the PTO drive pulley of the power unit.
7. Move the secondary S.D.L.A. lever* left and right to release pressure from the auxiliary hydraulic circuit. Disconnect the hydraulic quick couplers from the power unit and lay the hoses across the fan belt cover. Do not allow couplers to lay in dirt or snow.
8. Disconnect the electric plug (if equipped).
9. Disengage the attachment hitch lock*.
10. Restart the power unit and back slowly away from the snow blower.

Snow Blower Operating Procedure

Before operation, perform daily inspection, verify weight transfer is set properly, and verify the skid shoes are set at the desired height. Note: Operating with the weight transfer at the maximum setting will increase traction and reduce skid shoe wear.

Move the machine into position to start blowing. Rotate the discharge chute to the desired direction and adjust the discharge chute deflector to the desired angle. Always direct the discharged snow into open areas. Whenever possible, blow snow with the wind direction.

With the power unit's engine running between 2,000 and 2,500 RPM, engage the PTO switch. Adjust the throttle to the desired engine RPM.

Lower the snow blower to the ground and place the power unit's primary S.D.L.A lever in the float position by pushing it to the right until the detent engages. The lever will stay in this position until intentionally removed.

Drive forward slowly while keeping a close watch for potential hazards. Adjust the discharge chute rotation and the discharge chute deflector angle as necessary to keep the discharged snow directed to open areas.

* Refer to power unit owner's manual for operation of power unit controls.

GENERAL OPERATION

Transport of Snow Blower

Transport the snow blower with the power unit front hitch and snowblower raised to reduce wear of the equipment. Travel slowly when transporting over undulating or rough surfaces to maintain control of power unit and to reduce the shock to the machine. Travel slowly when transporting on slippery surfaces. Always disengage the PTO before transporting the snow blower.

Discharge Chute Rotation

Move the secondary S.D.L.A. lever to the left or right and hold in position to rotate the discharge chute. When the discharge chute is pointed in the desired direction, release the secondary S.D.L.A. lever to stop chute rotation.

Discharge Chute Deflector Adjustment (Manual)

Release the discharge chute adjustment link by pulling to the side. Adjust the discharge chute deflector to the desired angle. Engage the discharge chute adjustment link to lock in place.

Discharge Chute Deflector Adjustment (Optional Actuator Control)

Use the power unit's momentary switch(es) to adjust the angle of the discharge chute deflector. Hold the switch until the discharge chute deflector reaches the desired angle, then release the switch.

Rear Skid Shoe Adjustment

Skid shoes are provided to keep the cutting edge off the surface to be cleaned, especially when clearing snow from gravel driveways or roadways.

The rear skid shoe height is determined by the placement of spacer washers between the skid shoe and the skid shoe mount. Extra spacer washers are stored on top of the skid shoe mount.

Determine the number of spacer washers that need to be moved to reach the desired skid shoe height.

⚠ WARNING

When making adjustments with the snow blower in the raised position, the snow blower must be supported securely with blocks or jack stands. Hydraulic drift or accidental release of hydraulic pressure could allow the snow blower to lower and trap a person or appendage, if the snow blower is not securely supported.

Raise the snow blower to the highest position and

support securely with blocks or jack stands.

Remove the lynch pin (A) and the spacer washers (B) from the top of the skid shoe mount.



Remove the skid shoe from the bottom of the skid shoe mount. Add or remove spacer washers to reach the desired skid shoe height and insert the skid shoe into the skid shoe mount. Place any extra spacer washers on top of the skid shoe mount and fasten skid shoe in place with the lynch pin. Both the right and left skid shoes should be set at the same height. Remove the blocks or jack stands and lower the snow blower to the ground.

Front Skid Shoe Adjustment



With the power unit and snow blower parked on a level surface and the rear skid shoes set at the correct height, lower the snow blower until the rear skid shoes are resting on the ground. Set the front skid shoes at the desired position.

GENERAL OPERATION

Clearing a Blockage

⚠ WARNING

Always set the parking brake, shut off power unit engine, remove the ignition key, and ensure all moving parts have come to a complete stop before attempting to clear a blockage.

Never attempt to clear a blockage with your hands. Use the provided chute cleaning tool to remove blockages.

Keep hands, feet, and clothing away from all power driven parts when loosening and removing a blockage.

If a blockage occurs in the snow blower, immediately shut off the PTO and stop the power unit. Set the parking brake, shut off the engine, and remove the ignition key.

Use the chute cleaning tool (A) to remove blockages in the discharge chute and fan throat area.

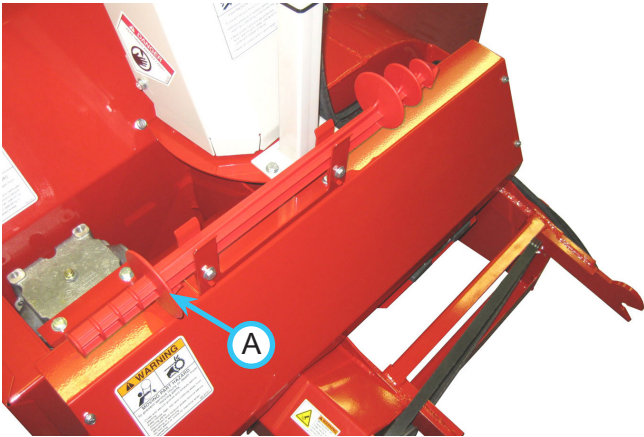

The discharge chute guard (B) can be unfastened at the top and rotated out of the way to allow access to the blockage.

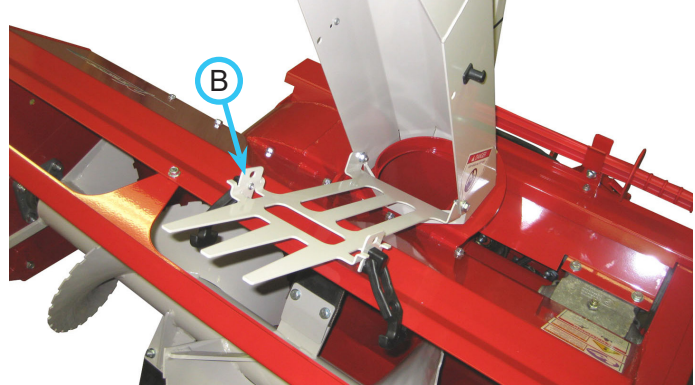

Use the cleaning tool to break up and pry apart the blockage. When the blockage has been completely cleared, fasten the discharge chute guard back in place.

⚠ WARNING

Never operate the snow blower without the discharge chute guard in place and securely fastened.

SERVICE



Attention

If any component requires replacement, use only original Ventrac replacement parts.

Cleaning & General Maintenance

For best results, and to maintain the finish of the KX523, clean or wash the snow blower to remove dirt, gravel, and salt deposits. Remove any ice or snow accumulations from the auger, fan, fan housing, and discharge chute.



Attention

To maintain the finish of the power unit and attachment, thoroughly wash the equipment after each use to remove any corrosive agents (e.g., salt). Failure to clean the equipment may result in corrosion of (including but not limited to) steel, aluminum, and electrical components. Equipment that will experience repeated exposure to corrosive agents should be pretreated with a corrosion preventative.

Cutting Edge Reversal/Replacement

If the cutting edge wears down near the snow blower frame structure, remove the cutting edge and flip over so the unworn top edge is now on the bottom. Reinstall the cutting edge onto the snow blower. When both sides of the cutting edge have been worn down, the cutting edge will need to be replaced.

Skid Shoe Replacement

Skid shoes should be replaced when wear surface is less than 1/8" (32. mm) thick.

Vertical Cutting Edge Adjustment

The vertical cutting edges can be adjusted to provide either a 52" (132 cm) or 54" (137 cm) cutting width. If the short flanges are mounted to the snow blower, the cutting width is 52" (132 cm). If the long flanges are mounted to the snow blower, the cutting width is 54" (137 cm). To switch from one cutting width to the other, rotate the cutting edges 180 degrees. Do not switch cutting edges to opposite sides of the snow blower.

Belt Inspection/Replacement

Inspecting the drive belts of the snow blower can prevent sudden belt failure by finding problems before they cause a belt to break.

Typical wear on a drive belt may result in the conditions shown in the diagram. If any of these conditions occur, the drive belt will require replacement.



Glazing



Streaked Sidewalls



Cracks



Tensile Break



Separation

Belt Size	Venture Part #	
PTO Drive Belt (power unit to snow blower)	B50	81.B050
Gearbox Drive Belt	B35	81.B035
Auger Drive Belt	B50	81.B050
Fan Drive Belt	B55	81.B055
Top Auger Drive Belt (optional deep snow kit)	B40	81.B040

Fan Drive Belt Replacement

⚠ WARNING

Always set the parking brake, shut off power unit engine, remove the ignition key, and ensure all moving parts have come to a complete stop before inspecting components, or attempting any repair or adjustment.

1. Remove the gearbox/fan belt cover from the snow blower.

⚠ CAUTION

Spring may be under high tension. Use caution when releasing spring, as pinching may occur.

2. Release the fan drive belt tensioning spring (A) and the gearbox drive belt tensioning spring (B).

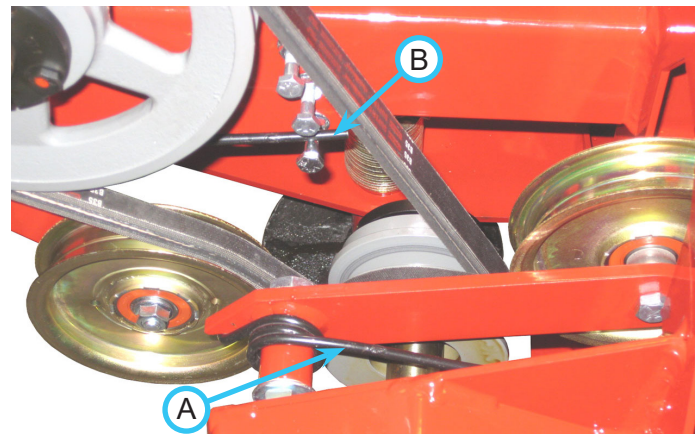

SERVICE

3. Remove the four bolts (C) from the bracket that holds the rear blower shaft bearing.

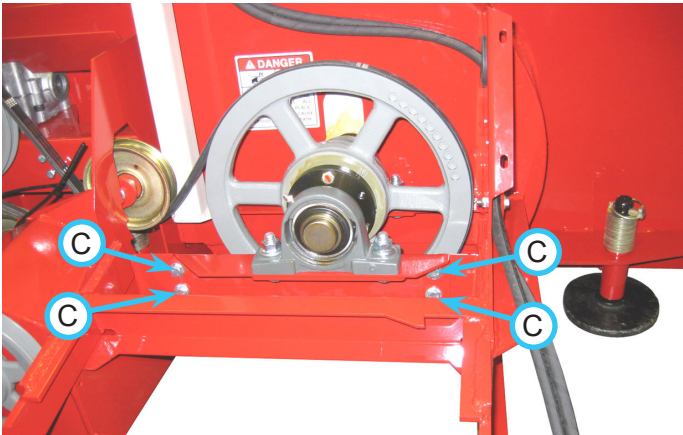

4. Rotate the bracket (D) as shown to allow the fan drive belt to be removed.

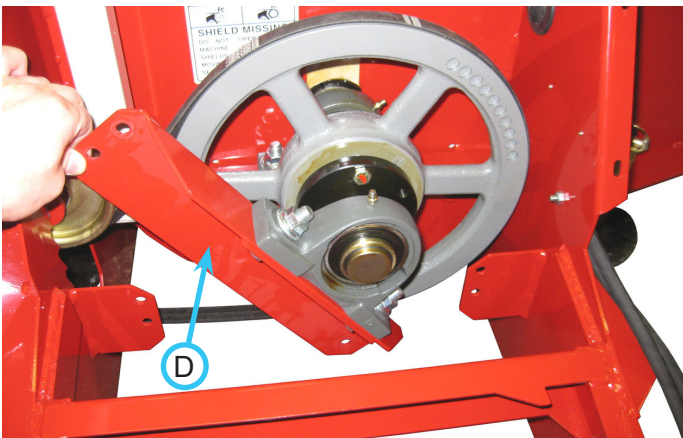

5. Remove the gearbox drive belt.
6. Remove the old fan drive belt and install the new belt onto the pulleys.
7. Reinstall the gearbox drive belt.
8. Rotate the bracket back into place and install the four bolts.
9. Engage the fan drive belt tensioning spring and the gearbox drive belt tensioning spring.
10. Reinstall the gearbox/fan belt cover.

Gearbox Drive Belt Replacement

1. Remove the gearbox/fan belt cover from the snow blower.

⚠ CAUTION

Spring may be under high tension. Use caution when releasing spring, as pinching may occur.

2. Release the gearbox drive belt tensioning spring.
3. Remove the old gearbox drive belt and install a

new drive belt onto the pulleys.

4. Engage the gearbox drive belt tensioning spring.
5. Reinstall the gearbox/fan belt cover.

Auger Drive Belt Replacement

1. Remove the auger drive belt cover.

⚠ CAUTION

Spring may be under high tension. Use caution when releasing spring, as pinching may occur.

2. Release the auger belt tension spring.
3. Remove the old auger drive belts and install the new drive belts onto the pulleys.
4. Engage the auger belt tensioning spring.
5. Reinstall the auger drive belt cover.

Deep Snow Auger Drive Belt Replacement

1. Remove the top auger drive belt cover from the snow blower.

⚠ CAUTION

Spring may be under high tension. Use caution when releasing spring, as pinching may occur.

2. Release the top auger drive belt tensioning spring.
3. Remove the old top auger drive belt and install a new drive belt onto the pulleys.
4. Engage the top auger drive belt tensioning spring.
5. Reinstall the top auger drive belt cover.

Belt Tension Adjustment

The belt spring tension is adjustable. The belt tension is factory set with the least amount of tension. This allows some belt slippage to protect the gearbox and drive components in the event an immovable object stops the auger or fan. If excessive belt slippage occurs in normal operating conditions, belt tension may be increased by moving the spring arm to a different belt tightener notch or bolt.

SERVICE

Lubrication Locations

Lubrication is required at the following locations using a lithium complex NLGI #2 grease. Refer to the maintenance schedule for service intervals. Use only one pump of grease.

Main Auger Bearings
Deep Snow Top Auger Bearings (if equipped)

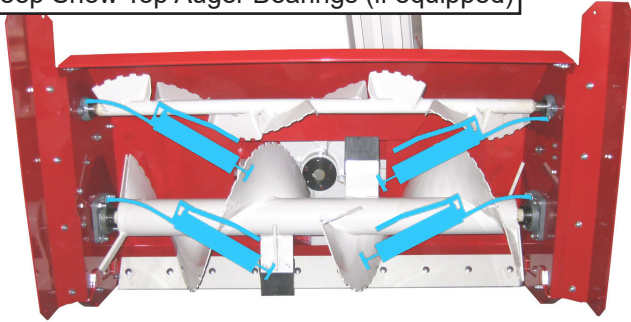

Fan Shaft Bearings

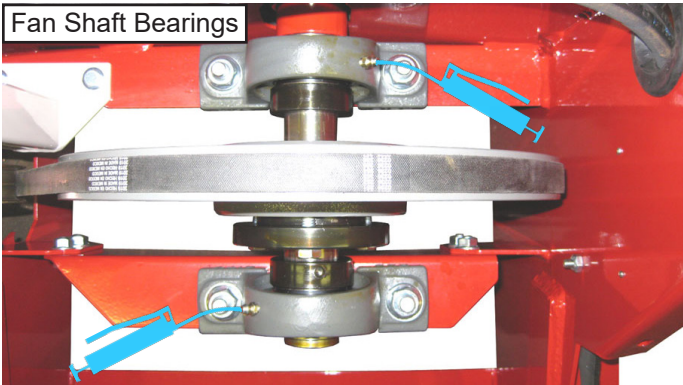

Drive Shaft Bearings

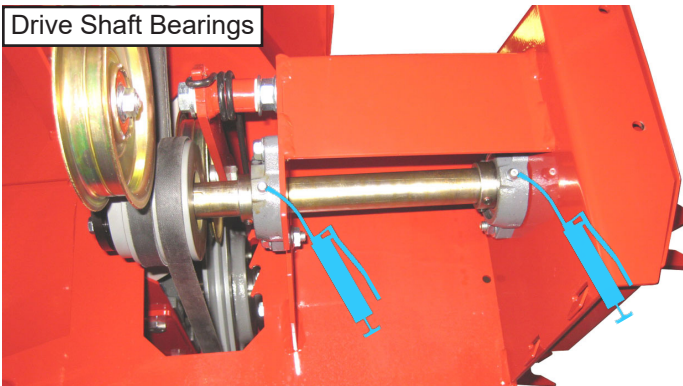

Discharge Chute Rotation Chain

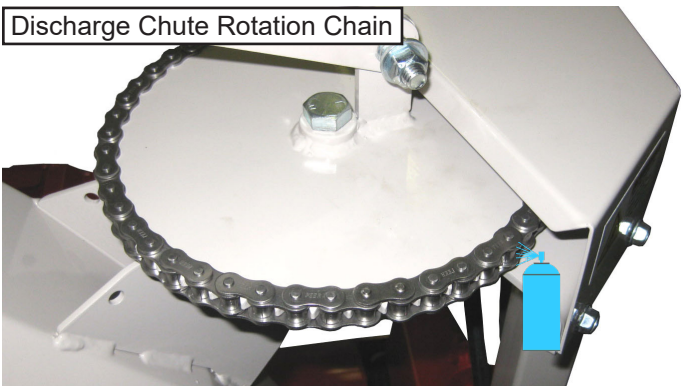

Checking Gearbox Oil Level

1. Detach the snow blower from the power unit.
2. Clean the top of the gearbox and remove the breather plug from the top port.
3. Check the oil level in the gearbox. The oil level should be maintained at approximately half full. If oil level is low, add 80-90 synthetic gear oil until the proper level is reached.
4. Reinstall the breather plug into the top port of the gearbox.

Changing Gearbox Oil

1. Detach the snow blower from the power unit.
2. Clean the top and bottom of the gearbox.
3. Remove the breather plug from the top port of the gearbox.
4. Place a drain pan beneath the gearbox.
5. Remove the pipe plug from the bottom port of the gearbox and allow the gear oil to drain.
6. Reinstall the pipe plug into the bottom port of the gearbox.
7. Add 80-90 synthetic gear oil until the proper level is reached.
8. Reinstall the breather plug into the top port of the gearbox.

SERVICE

Storage

Preparing the Snow Blower for Storage

1. Clean the snow blower.



Attention

To maintain the finish of the power unit and attachment, thoroughly wash the equipment to remove any corrosive agents (e.g., salt). Failure to clean the equipment may result in corrosion of (including but not limited to) steel, aluminum, and electrical components.

2. Inspect for loose or missing hardware, damaged components, or signs of wear.
3. Inspect safety decals, Replace any safety decals that are faded, illegible, or missing.
4. Inspect hydraulic hoses and fittings to ensure tight, leak free connections. Repair or replace any damaged or worn components.
5. Inspect belts for signs of damage or wear and replace as required.
6. Inspect cutting edge and skid shoes for wear and service as required.
7. Service all lubrication points and inspect gearbox oil level.
8. Wipe off all excess grease or oil.

Removing the Snow Blower from Storage

1. Clean the snow blower to remove any accumulated dust or debris.
2. Inspect the snow blower as instructed in the daily inspection section of this manual.
3. Test the snow blower to ensure all components are working properly.

SERVICE

Maintenance Schedule

KX523 Snow Blower

Maintenance Schedule			Grease & Lubrication: See Lubrication Section																									
			# of Locations	# of Pumps	AS NEEDED	Daily	At 50 Hours	At 100 Hours	At 150 Hours	At 200 Hours	At 250 Hours	At 300 Hours	At 350 Hours	At 400 Hours	At 450 Hours	At 500 Hours	At 550 Hours	At 600 Hours	At 650 Hours	At 700 Hours	At 750 Hours	At 800 Hours	At 850 Hours	At 900 Hours	At 950 Hours	At 1000 Hours	Yearly	
Auger Shaft Bearing	2	1	**	✓	✓	✓	✓	✓	✓	✓	✓	✓	✓	✓	✓	✓	✓	✓	✓	✓	✓	✓	✓	✓	✓	✓	✓	
Drive Shaft Bearing	2	1	**	✓	✓	✓	✓	✓	✓	✓	✓	✓	✓	✓	✓	✓	✓	✓	✓	✓	✓	✓	✓	✓	✓	✓	✓	
Fan Shaft Bearing	2	1	**	✓	✓	✓	✓	✓	✓	✓	✓	✓	✓	✓	✓	✓	✓	✓	✓	✓	✓	✓	✓	✓	✓	✓	✓	
Optional Top Auger Shaft Bearing	2	1	**	✓	✓	✓	✓	✓	✓	✓	✓	✓	✓	✓	✓	✓	✓	✓	✓	✓	✓	✓	✓	✓	✓	✓	✓	
Chute Rotation Roller Chain	1		✓	✓	✓	✓	✓	✓	✓	✓	✓	✓	✓	✓	✓	✓	✓	✓	✓	✓	✓	✓	✓	✓	✓	✓	✓	
Check Gearbox Oil Level				✓		✓			✓			✓			✓			✓			✓			✓			✓	
Change Gearbox Oil. Replace w/ 80-90 Synthetic gear oil				✓											✓												✓	
Inspection																												
Inspect for Loose, Missing, or Worn Components.			✓																									
Inspect Drive Belts, Pulleys, Cutting Edge, Skid Shoes, Fittings, and Hydraulic Hoses			✓																									
Inspect Safety Decals			✓																									

** Operation in severe conditions may require more frequent service intervals.

Maintenance Checklist

KX523 Snow Blower

Maintenance Checklist			Grease & Lubrication: See Lubrication Section																									
			# of Locations	# of Pumps	At 50 Hours	At 100 Hours	At 150 Hours	At 200 Hours	At 250 Hours	At 300 Hours	At 350 Hours	At 400 Hours	At 450 Hours	At 500 Hours	At 550 Hours	At 600 Hours	At 650 Hours	At 700 Hours	At 750 Hours	At 800 Hours	At 850 Hours	At 900 Hours	At 950 Hours	At 1000 Hours	Yearly			
Auger Shaft Bearing	2	1																										
Drive Shaft Bearing	2	1																										
Fan Shaft Bearing	2	1																										
Optional Top Auger Shaft Bearing	2	1																										
Chute Rotation Roller Chain	1																											
Check Gearbox Oil Level																												
Change Gearbox Oil. Replace w/ 80-90 Synthetic gear oil																												
Inspection																												
Inspect for Loose, Missing, or Worn Components.																												
Inspect Drive Belts, Pulleys, Cutting Edge, Skid Shoes, Fittings, and Hydraulic Hoses																												
Inspect Safety Decals																												

** Operation in severe conditions may require more frequent service intervals.

SPECIFICATIONS

Dimensions

Overall Height	56.5 inches (143.5 cm)
Overall Length	49 inches (124.5 cm)
. with KT 4000 series power unit -	116.75 inches (296.5 cm)
Overall Width	52 inches (132.1 cm)
Auger Opening Width	48 inches (121.9 cm)
Weight	515 pounds (233.6 kg)
Main Auger Diameter	16 inches (40.6 cm)
Main Auger Speed	197 RPM*
Auxiliary Auger Diameter	8 inches (20.3 cm)
Auxiliary Auger Speed	105 RPM*
Fan Diameter	19.5 inches (49.5 cm)
Fan Shaft Speed.	790 RPM*
Chute Rotation.	180 degrees
Blowing Distance	Approximately 35-40 feet (10.7-12.2 m)
Snow Capacity**	4,500 lbs/minute (2041.2 kg/minute)

*Based on engine speed of 3,200 RPM

**Capacity is dependent upon conditions.

Features

- 2 Stage Snow Blower
- Vertical Discharge Chute Adjustment (Manual)
- Hydraulically Controlled Direction Discharge Chute, Left to Right
- Extra Heavy Duty Shaft and Bearings
- Adjustable Skid Shoes

SPECIFICATIONS

Noise Emissions¹

Measured Sound Power Level, dB(A)	95.6
Sound Power Uncertainty, dB(A)	2.0
Sound Pressure Level at Operator's Ear, dB(A)	77.5
Sound Pressure Uncertainty, dB(A)	2.0

Note 1: Specifications subject to change without notice.

EC Declaration of Conformity Ventrac KX523

Manufacturer	Venture Products, Inc. 500 Venture Drive Orrville, OH 44667 USA
Authorized Representative (also authorized to compile the technical file)	Lars Persson LAPAB MASKIN AB Box 46, S-734 22 Hallstahammar Flädervägen 5, 734 38 Hallstahammar SWEDEN
Technical File Keeper	Ryan Steiner Venture Products, Inc. 500 Venture Drive Orrville, OH 44667 USA
Description	52 inch snow blower attachment
Model Name	Ventrac KX523 Snow Blower
Model Number	39.55427
Serial Number	KX523-Axxxxx
This Product Conforms to Directives	2006/42/EC
Ryan Steiner Director of Engineering 	23-July-2015 Orrville, Ohio USA

PARTS

ILLUSTRATED DRAWING Main Frame & Auger

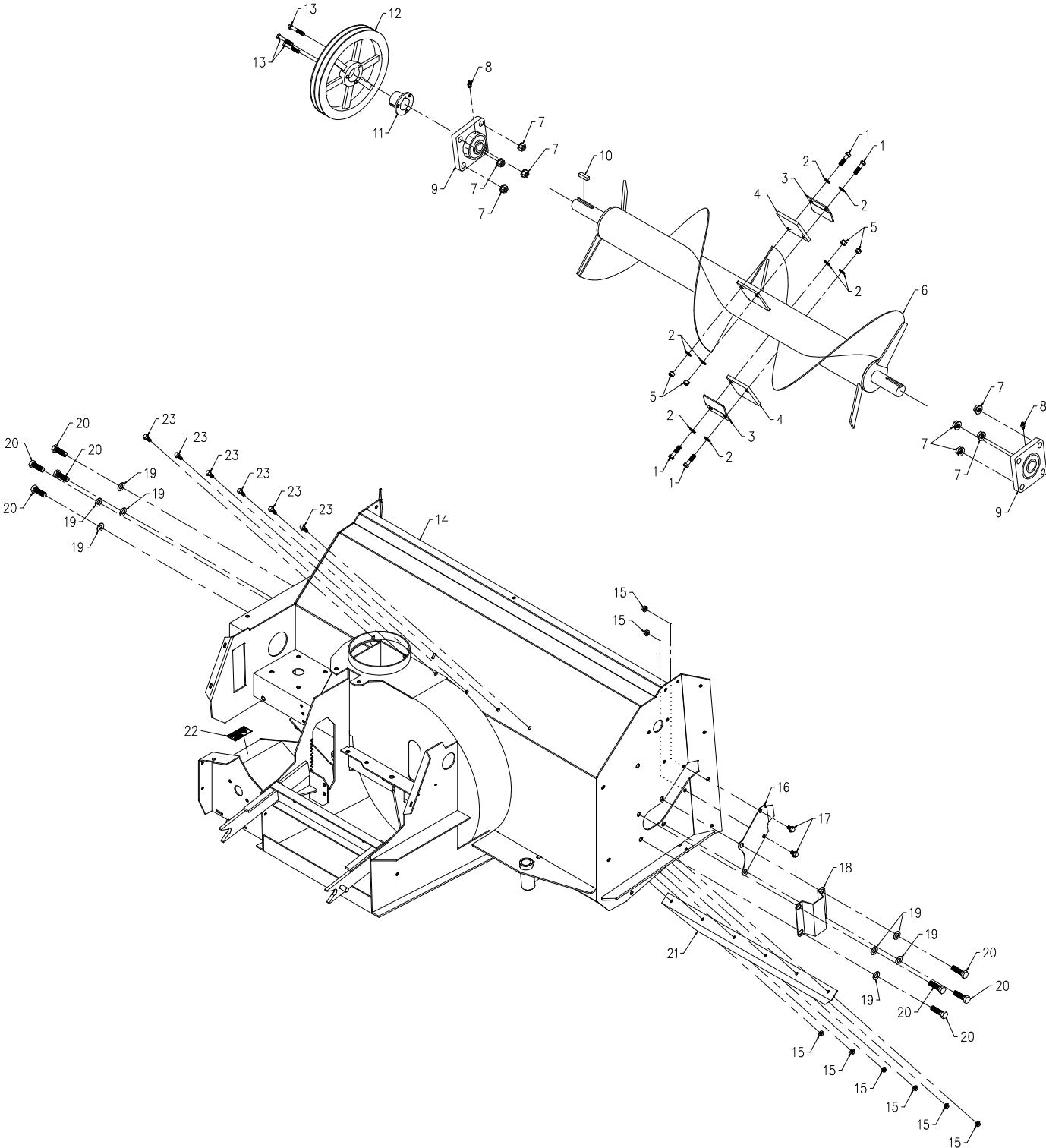

PARTS

Main Frame & Auger

REF.	PART NO.	DESCRIPTION	QTY.
1	90.0612	.BOLT, 3/8-16 USS X 1 1/2	4
2	95.06	.WASHER, FLAT 3/8 SAE	8
3	64.1088	.CLAMP, RUBBER AUGER PADDLES	2
4	44.0181	.PADDLE, 1/2" 3 PLY 3/8 X 1/16	2
5	99.A06N	.LOCKNUT, NYLON 3/8-16	4
6	80.0369	.AUGER, SNOWBLOWER	1
7	99.SF08	.NUT, SRF 1/2-13 USS	8
8	29.GF0001	.GREASE FTG, 1/4 SAE ST	2
9	55.FB22023	.BEARING, FLANGE BLOCK 1-7/16"	2
10	85.K0610	.KEY, 3/8 X 1 1/4	1
11	83.SK23	.BUSHING, 1 7/16" SK	1
12	83.2B110SK	.PULLEY, 2 B 11" 2-GROOVE	1
13	90.0516	.BOLT, 5/16-18 USS X 2	3
14	62.1324	.FRAME, MAIN BLOWER	1
15	99.SF05	.NUT, SRF 5/16-18 USS	8
16	64.1283	.BRACKET, AUGER INSTALL ACCESS	1
17	99.SF0504	.BOLT, SRF 5/16-18USS X 1/2	2
18	60.0982	.SHIELD, AUGER SHAFT END RH	1
19	95.08	.WASHER, FLAT 1/2 SAE	8
20	90.0814	.BOLT, 1/2-13 USS X 1 3/4	8
21	60.0873	.PLATE, FAN DISCHARGE GUIDE	1
22	00.0216	.DECAL, WARNING MOVING PARTS	1
23	99.SF0506	.BOLT, SRF 5/16-18 USS X 3/4	6

PARTS

ILLUSTRATED DRAWING PTO Drive & Gearbox Drive

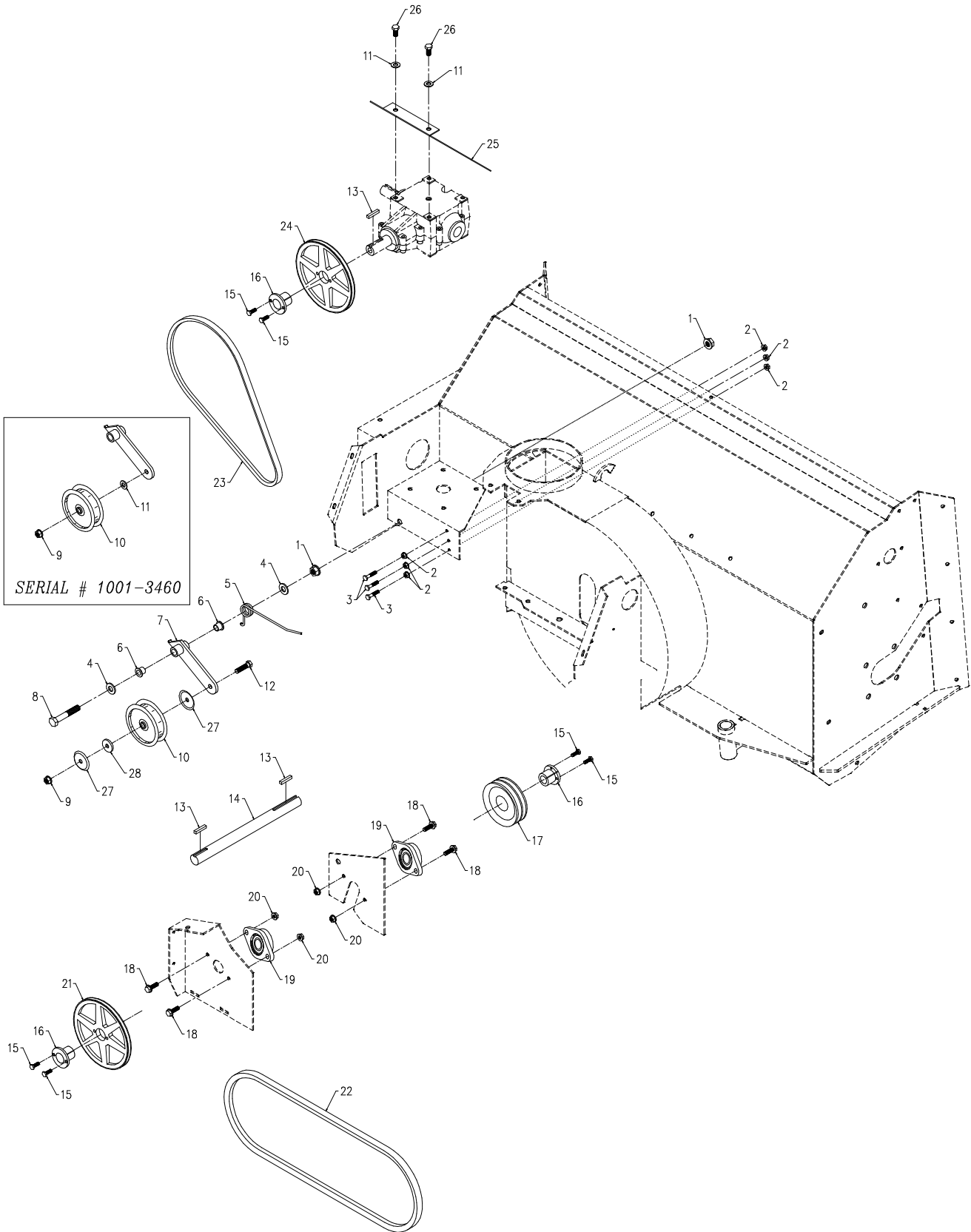

PARTS

PTO Drive & Gearbox Drive

REF.	PART NO.	DESCRIPTION	QTY.
1	99.SF08	NUT, SRF 1/2-13 USS	2
2	99.SF04	NUT, SRF 1/4-20 USS	6
3	90.0410	BOLT, 1/4-20 USS X 1 1/4	3
4	95.08	WASHER, FLAT 1/2 SAE	2
5	41.0066	SPRING, SINGLE TORSION LH	1
6	85.B0027	BUSHING, 1/2 ID X 5/8 OD X 5/8	2
7	40.0312	ARM, GEAR BOX BELT IDLER	1
8	90.0824	BOLT, 1/2-13 USS X 3	1
9	99.SF06	NUT, SRF 3/8-16 USS	1
10	83.0037	PULLEY, IDLER FLAT 4" X 3/8	1
11	95.06	WASHER, FLAT 3/8 SAE	3
12	90.0612	BOLT, 3/8-16 USS X 1 1/2	1
13	85.K0408	KEY, 1/4 X 1	3
14	80.0345	SHAFT, TGP 1" X 13-3/4L	1
15	90.0406	BOLT, 1/4-20 USS X 3/4	6
16	83.H16S	BUSHING, 1" SPLIT 1/4" KEY	3
17	83.2BK32H	PULLEY, 2BK 3.2" H-BUSH	1
18	99.SF0508	BOLT, SRF 5/16-18 USS X 1	4
19	55.FB16016-1	BEARING, FLANGE BLOCK 1"	2
20	99.SF05	NUT, SRF 5/16-18 USS	4
21	83.BK75H	PULLEY, 7.5"	1
22	81.B050	BELT, B50	1
23	81.B035	BELT, B35	1
24	83.BK80H	PULLEY, 8" H-BUSH	1
25	60.0870	SHIELD, GEARBOX FINAL DRIVE	1
26	90.0606	BOLT, 3/8-16 USS X 3/4	2
27	60.1056	COVER, PULLEY (Serial # 3461-)	2
28	99.G0014	WASHER, 3/8 USS FW .165 THK (Serial # 3461-4299)	1

PARTS

ILLUSTRATED DRAWING Gearbox & Auger Drive

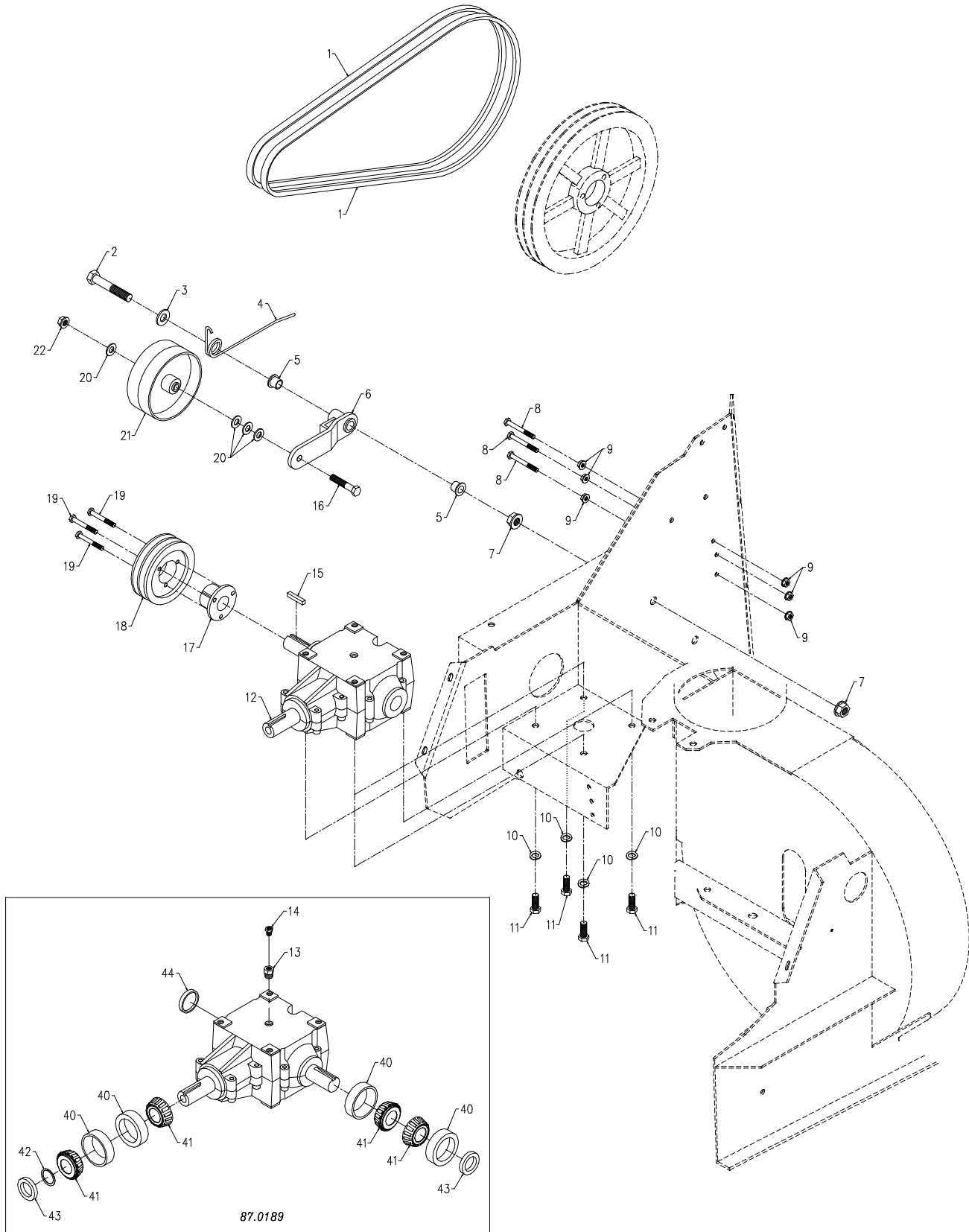

PARTS

Gearbox & Auger Drive

REF.	PART NO.	DESCRIPTION	QTY.
1	81.B050	.BELT, B50	2
2	90.0824	.BOLT, 1/2-13 USS X 3	1
3	95.08	.WASHER, FLAT 1/2 SAE	1
4	41.0066	.SPRING, SINGLE TORSION LH	1
5	85.B0027	.BUSHING, 1/2 ID X 5/8 OD X 5/8	2
6	40.0314	.ARM, AUGER DRIVE BELT IDLER	1
7	99.SF08	.NUT, SRF 1/2-13 USS	2
8	90.0418	.BOLT, 1/4-20 USS X 2 1/4	3
9	99.SF04	.NUT, SRF 1/4-20 USS	6
10	96.06	.WASHER, LOCK 3/8	4
11	90.0608	.BOLT, 3/8-16 USS X 1	4
12	87.0189	.GEARBOX, 1" SHAFT 2:1 CW/CCW	1
13	29.B0204G	.PIPE, BUSHING 1/8 X 1/4 GALV	1
14	29.0090	.PIPE, BREATHER PLUG 1/8	1
15	85.K0408	.KEY, 1/4 X 1	1
16	90.0616	.BOLT, 3/8-16 USS X 2	1
17	83.SH16	.BUSHING, 1" SH	1
18	83.2B36SH	.PULLEY, 2 B 3.6" 2-GROOVE	1
19	90.0416	.BOLT, 1/4-20 USS X 2	3
20	95.06	.WASHER, FLAT 3/8 SAE	A/R
21	83.0040	.PULLEY, IDLER FLAT 5" PLAIN	1
22	99.SF06	.NUT, SRF 3/8-16 USS	1
40	55.0076	.BEARING, CUP 1.980	4
41	55.0075	.BEARING, CONE 1.000	4
42	04.0026	.RETAINING RING, EXT 1.000 SHFT.	1
43	89.0075	.SEAL, OIL	2
44	89.0081	.SEAL, END CAP 1.50-25	1

PARTS

ILLUSTRATED DRAWING Fan & Fan Shaft

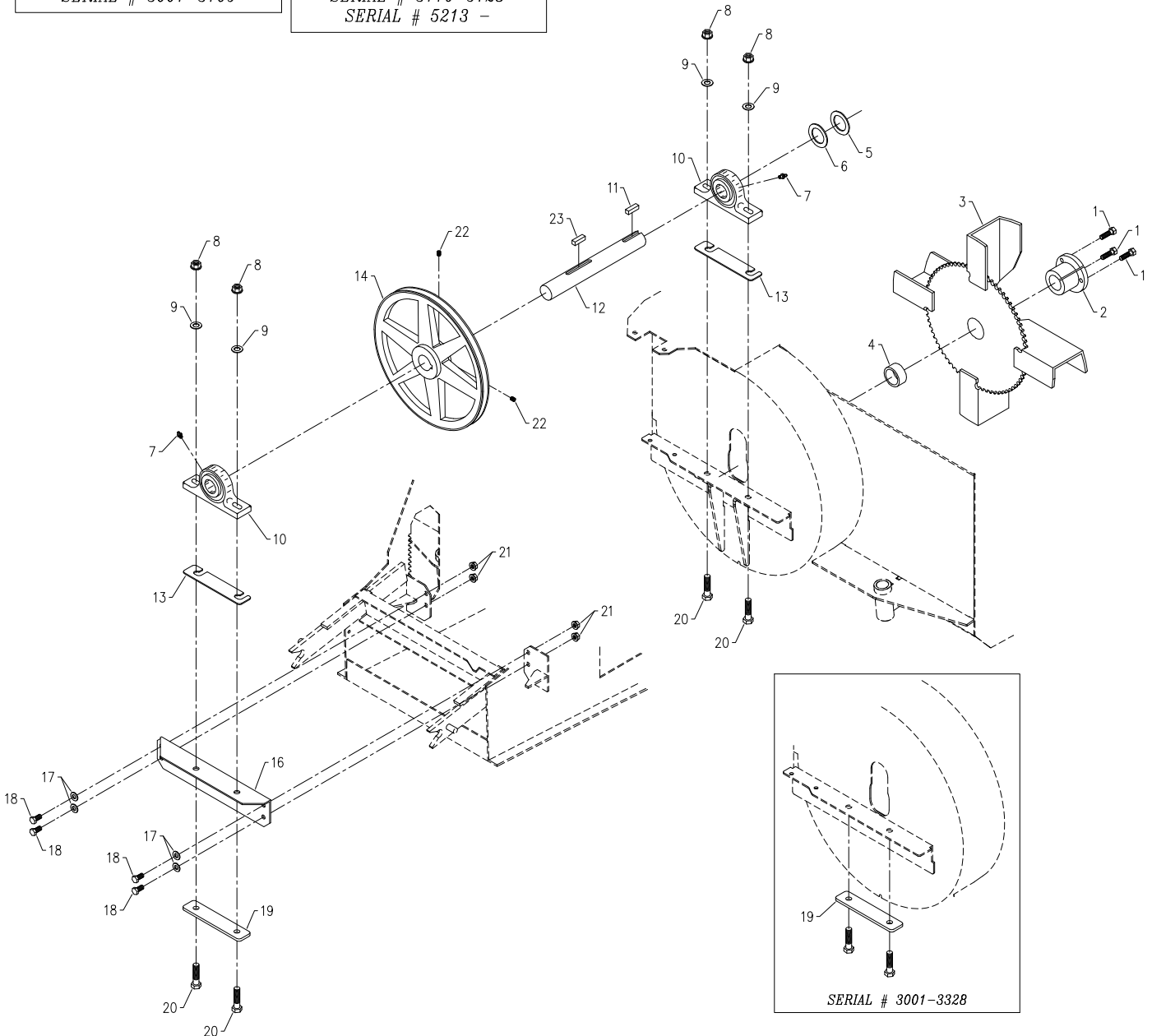
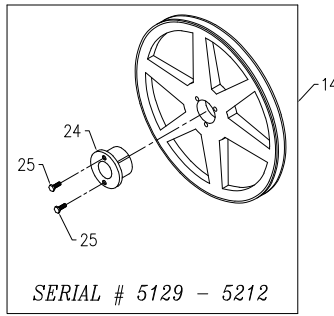
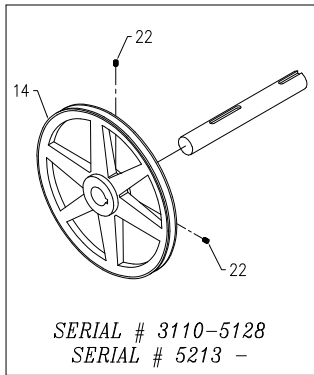
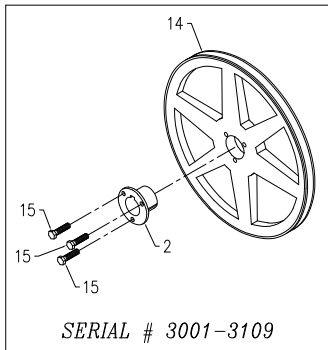

PARTS

Fan & Fan Shaft

REF.	PART NO.	DESCRIPTION	QTY.
1	90.0610	.BOLT, 3/8-16 USS X 1 1/4	3
2	83.Q123	.BUSHING, 1 7/16" Q1 (Serial # 3001-3109)	2
2	83.Q123	.BUSHING, 1 7/16" Q1 (Serial # 3110-)	1
3	80.0344	.BLOWER, FAN	1
4	64.1100	.BUSHING, 1-1/2 X 2 X 7/8L	1
5	99.B0031	.WASHER, MACH 1 1/2 14GA.	A/R
6	99.B0054	.WASHER, MACH 1 1/2 10GA.	A/R
7	29.GF0001	.GREASE FTG, 1/4 SAE ST	2
8	99.SF08	.NUT, SRF 1/2-13 USS.	4
9	95.08	.WASHER, FLAT 1/2 SAE	4
10	55.PB22023	.BEARING, PILLOW BLOCK 1 7/16	2
11	85.K0610	.KEY, 3/8 X 1 1/4	1
12	80.0346	.SHAFT, TGP 1-7/16 X 11-3/4L	1
13	64.1249	.SHIM, 12GA FAN BEARING	A/R
14	83.TB124	.PULLEY (Serial # 3001-3109)	1
14	83.BK13023	.PULLEY, 13" 1-7/16" BORE (Serial # 3110-5128)	1
14	70.8197	.KIT, FAN SHAFT PULLEY (Serial # 5129-5212)	1
14	83.BK13023	.PULLEY, 13" 1-7/16" BORE (Serial # 5213-)	1
15	90.0612	.BOLT, 3/8-16 USS X 1 1/2 (Serial # 3001-3109)	3
16	64.1085	.MOUNT, REAR ROTOR BEARING (Serial # 3001-3328)	1
16	64.1671	.MOUNT, REAR ROTOR BEARING (Serial # 3329-)	1
17	95.06	.WASHER, FLAT 3/8 SAE	4
18	90.0606	.BOLT, 3/8-16 USS X 3/4 (Serial # 3001-3328)	4
18	90.0608	.BOLT, 3/8-16 USS X 1 (Serial # 3329-)	4
19	64.1099	.PLATE, BEARING REINFORCEMENT (Serial # 3001-3328)	2
19	64.1099	.PLATE, BEARING REINFORCEMENT (Serial # 3329-)	1
20	90.0816	.BOLT, 1/2-13 USS X 2	4
21	99.SF06	.NUT, SRF 3/8-16 USS.	4
22	85.SS09	.SET SCREW, 5/16" X 3/8" (Serial # 3110-5128) (Serial # 5213-)	2
23	85.K0610	.KEY, 3/8 X 1 1/4 (Serial # 3110-5128)	1
23	85.K060410	.KEY, 3/8 X 1/4 X 1-1/4 (Serial # 5129-5212)	1
23	85.K0610	.KEY, 3/8 X 1 1/4 (Serial # 5213-)	1
24	83.H23	.BUSHING, 1 7/16" H (Serial # 5129-)	1
25	90.0406	.BOLT, 1/4-20 USS X 3/4 (Serial # 5129-)	2

PARTS

ILLUSTRATED DRAWING Fan Drive

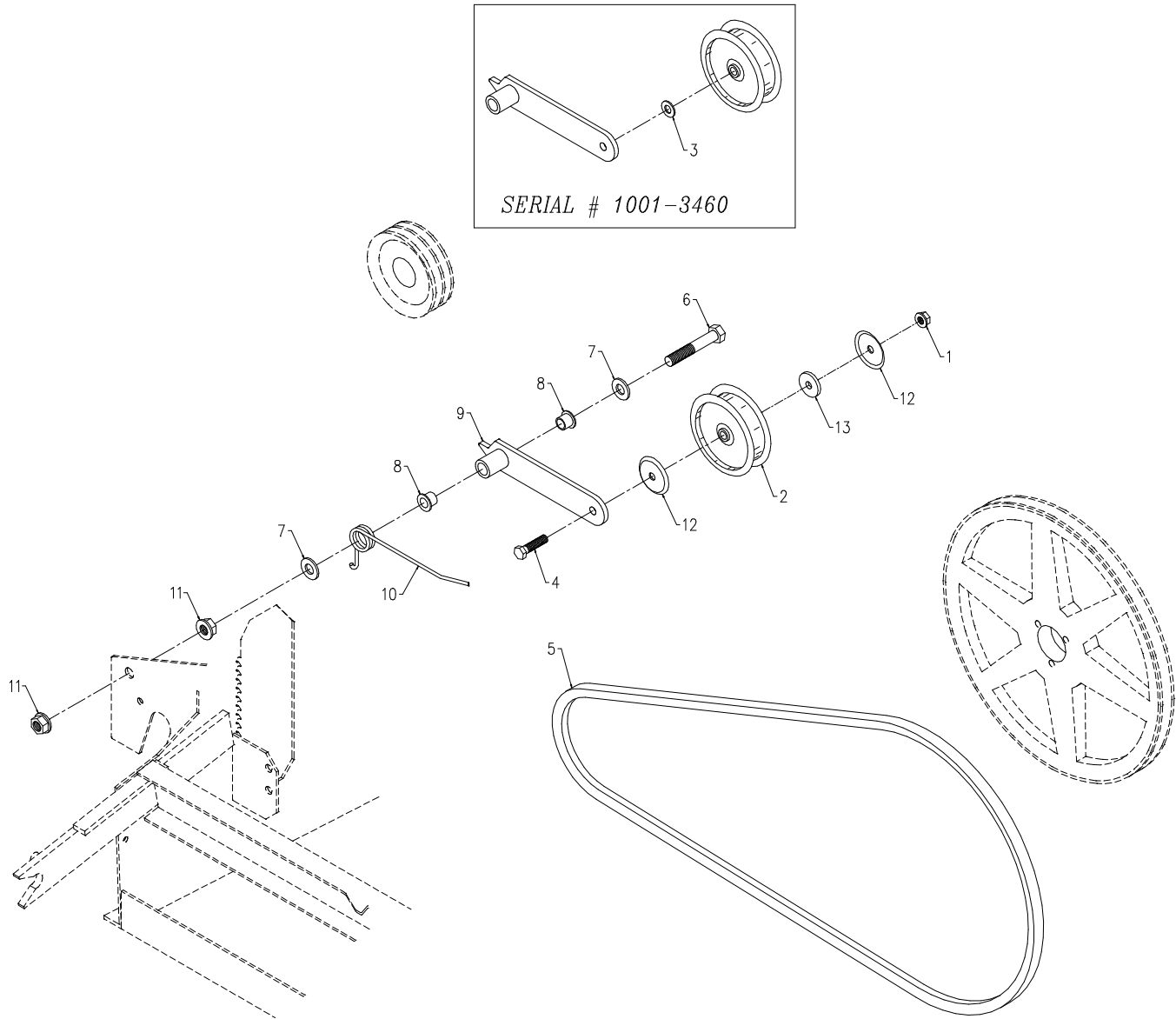

PARTS

Fan Drive

REF.	PART NO.	DESCRIPTION	QTY.
1	99.SF06	.NUT, SRF 3/8-16 USS.	1
2	83.0037	.PULLEY, IDLER FLAT 4" X 3/8.	1
3	95.06	.WASHER, FLAT 3/8 SAE (Serial # 1001-3460)	1
4	90.0612	.BOLT, 3/8-16 USS X 1 1/2.	1
5	81.0157	.BELT, BX55	1
6	90.0824	.BOLT, 1/2-13 USS X 3.	1
7	95.08	.WASHER, FLAT 1/2 SAE	2
8	85.B0027	.BUSHING, 1/2 ID X 5/8 OD X 5/8.	2
9	40.0313	.ARM, FAN DRIVE IDLER	1
10	41.0066	.SPRING, SINGLE TORSION LH	1
11	99.SF08	.NUT, SRF 1/2-13 USS.	2
12	60.1056	.COVER, PULLEY (Serial # 3461-)	2
13	99.G0014	.WASHER, 3/8 USS FW .165 THK (Serial # 3461-4299)	1

PARTS

ILLUSTRATED DRAWING Discharge Chute

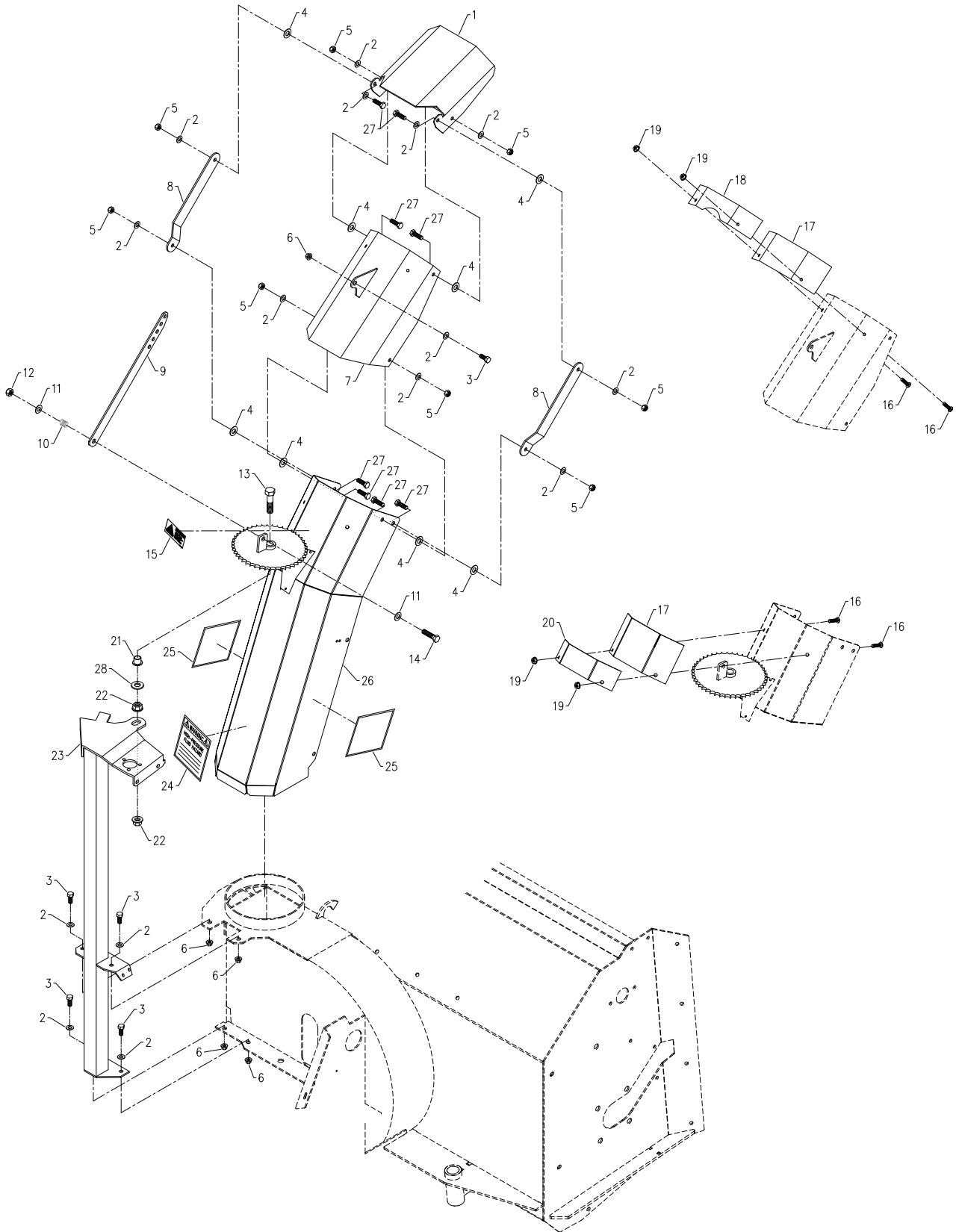

PARTS

Discharge Chute

REF.	PART NO.	DESCRIPTION	QTY.
1	62.0992	.CHUTE, FINAL EXTENSION	1
2	95.05	.WASHER, FLAT 5/16 SAE	15
3	90.0506	.BOLT, 5/16-18 USS X 3/4	5
4	05.0055	.WASHER, NYLON .34 X .74 X .062	8
5	99.A05	.LOCKNUT, STOVER 5/16-18 USS	8
6	99.SF05	.NUT, SRF 5/16-18 USS	5
7	62.0991	.CHUTE, MID DISCHARGE SECTION	1
8	42.0461	.LINK, CHUTE DEFLECTOR CONTROL	2
9	42.0462	.LINK, CHUTE DEFLECTOR ADJUST	1
10	41.0039	.SPRING, COMP. 9/16 OD X 5/8	1
11	95.06	.WASHER, FLAT 3/8 SAE	2
12	99.A06	.LOCKNUT, STOVER 3/8-16 USS	1
13	90.0816	.BOLT, 1/2-13 USS X 2	1
14	90.0612	.BOLT, 3/8-16 USS X 1 1/2	1
15	00.0218	.DECAL, WARNING PINCH POINT	1
16	99.K0069	.BOLT, BUT HD SOCK SS 1/4 X 5/8	4
17	44.0272	.PLASTIC, CHUTE LINER	2
18	64.1485	.CLAMP, CHUTE LINER UPPER	1
19	99.SF04SS	.NUT, SRF 1/4-20 USS STAINLESS	4
20	64.1484	.CLAMP, CHUTE LINER MAIN	1
21	85.B0027	.BUSHING, 1/2 ID X 5/8 OD X 5/8	1
22	99.SF08	.NUT, SRF 1/2-13 USS	2
23	62.0993	.POST, DISCHARGE CHUTE MT (Serial # 3001-3152)	1
23	62.1280	.POST, CHUTE MOUNT (Serial # 3153-)	1
24	00.0103	.DECAL, HAZARD-HIGH PRESS.FLUID	1
25	00.0123	.DECAL, KEEP HAND AND FEET AWAY (Serial # 3001-3904)	2
25	00.0409	.DECAL, DISCHARGE CHUTE SAFETY (Serial # 3905-)	2
26	62.0990	.CHUTE, MAIN BLOWER DISCHARGE	1
27	90.0508	.BOLT, 5/16-18 USS X 1	8
28	95.08	.WASHER, FLAT 1/2 SAE	1

PARTS

ILLUSTRATED DRAWING Discharge Chute Rotation Drive

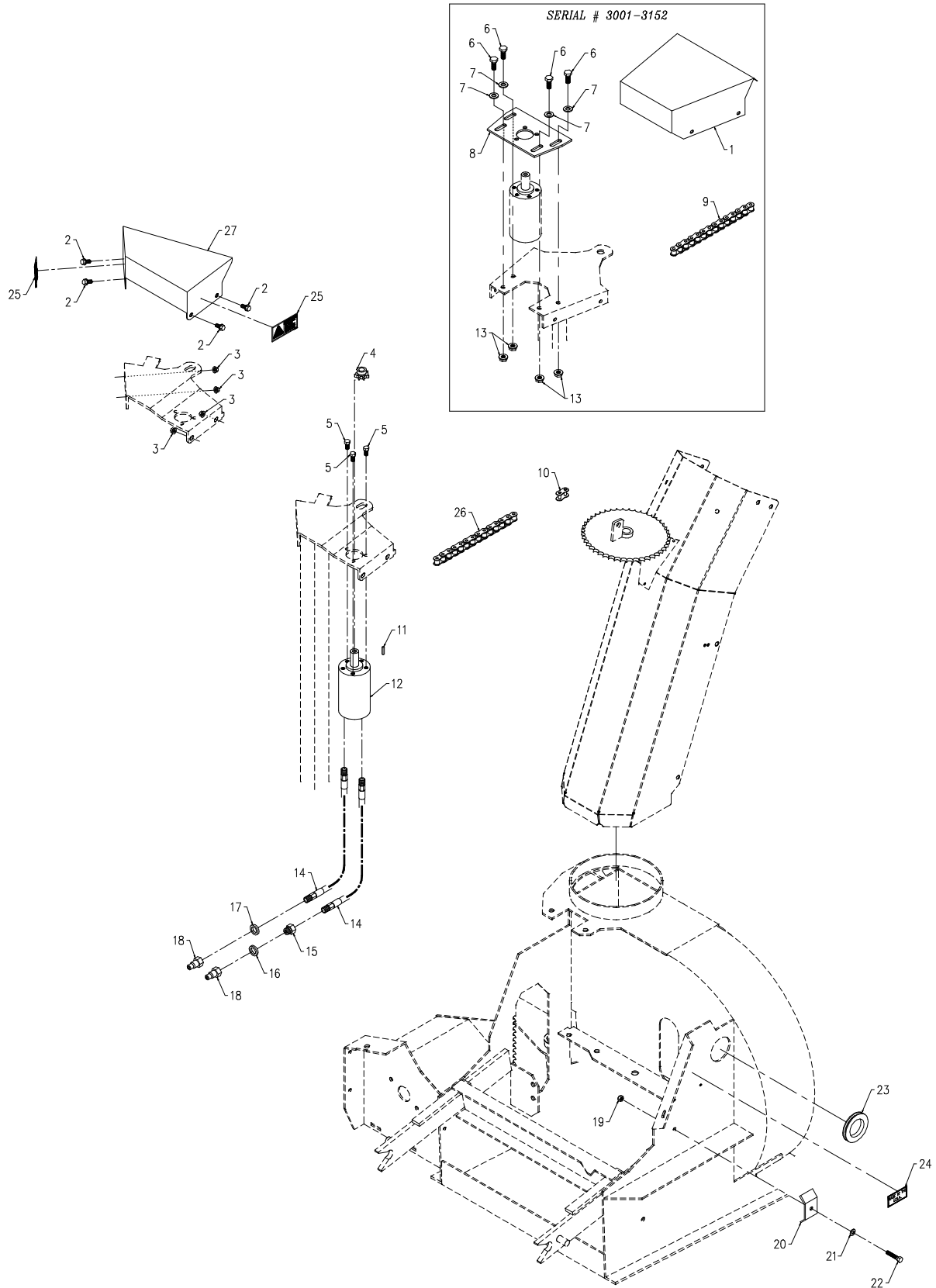

PARTS

Discharge Chute Rotation Drive

REF.	PART NO.	DESCRIPTION	QTY.
1	60.0872	.SHIELD, ROTATOR CHAIN COVER (Serial # 3001-3152)	1
2	99.SF0404-1	.BOLT, SRF 1/4-20 X 1/2 W/RUBBR	4
3	99.SF04	.NUT, SRF 1/4-20 USS	4
4	83.H409	.SPROCKET, #40 9-T HRD 5/8 BORE	1
5	91.0404	.BOLT, 1/4-28 SAE X 1/2	3
6	90.0506	.BOLT, 5/16-18 USS X 3/4 (Serial # 3001-3152)	4
7	95.05	.WASHER, FLAT 5/16 SAE (Serial # 3001-3152)	4
8	62.1000	.PLATE, HYDRA MOTOR MT (Serial # 3001-3152)	1
9	81.0147	.CHAIN, ROLLER #40 X 30-7/8 SS (Serial # 3001-3152)	1
10	81.0056-1	.LINK, CONN. #40 SS	1
11	85.K0307	.KEY, 3/16 X 5/8	1
12	21.0113	.MOTOR, HYD 1.93 CU.IN	1
13	99.SF05	.NUT, SRF 5/16-18 USS (Serial # 3001-3152)	4
14	20.0210	.HOSE, ASM C 1/4 X 78"-2750	2
15	29.0092	.FITTING, .025 ORIFICE 1/4 PIPE	1
16	05.0116	.WASHER, .544ID X .817 X.14 RED	1
17	05.0117	.WASHER, .544ID X .817 X.14 YEL	1
18	23.0104	.COUPLER, HYD. QUICK MALE 1/4	2
19	99.A04	.LOCKNUT, STOVER 1/4-20 USS	1
20	64.0673	.CLAMP, HYDRAULIC HOSE	1
21	95.04	.WASHER, FLAT 1/4 SAE	1
22	90.0410	.BOLT, 1/4-20 USS X 1 1/4	1
23	05.0040	.GROMMET, 1 1/2ID, 2-3/8OD, 3/32T	1
24	00.0100	.DECAL, MADE IN USA	1
25	00.0216	.DECAL, WARNING MOVING PARTS	2
26	81.0153	.CHAIN, ROLLER #40 X 28" SS (Serial # 3153-)	1
27	60.1013	.SHIELD, CHUTE ROTATION MOTOR (Serial # 3153-)	1

PARTS

ILLUSTRATED DRAWING Discharge Chute Guard & Cleaning Tool

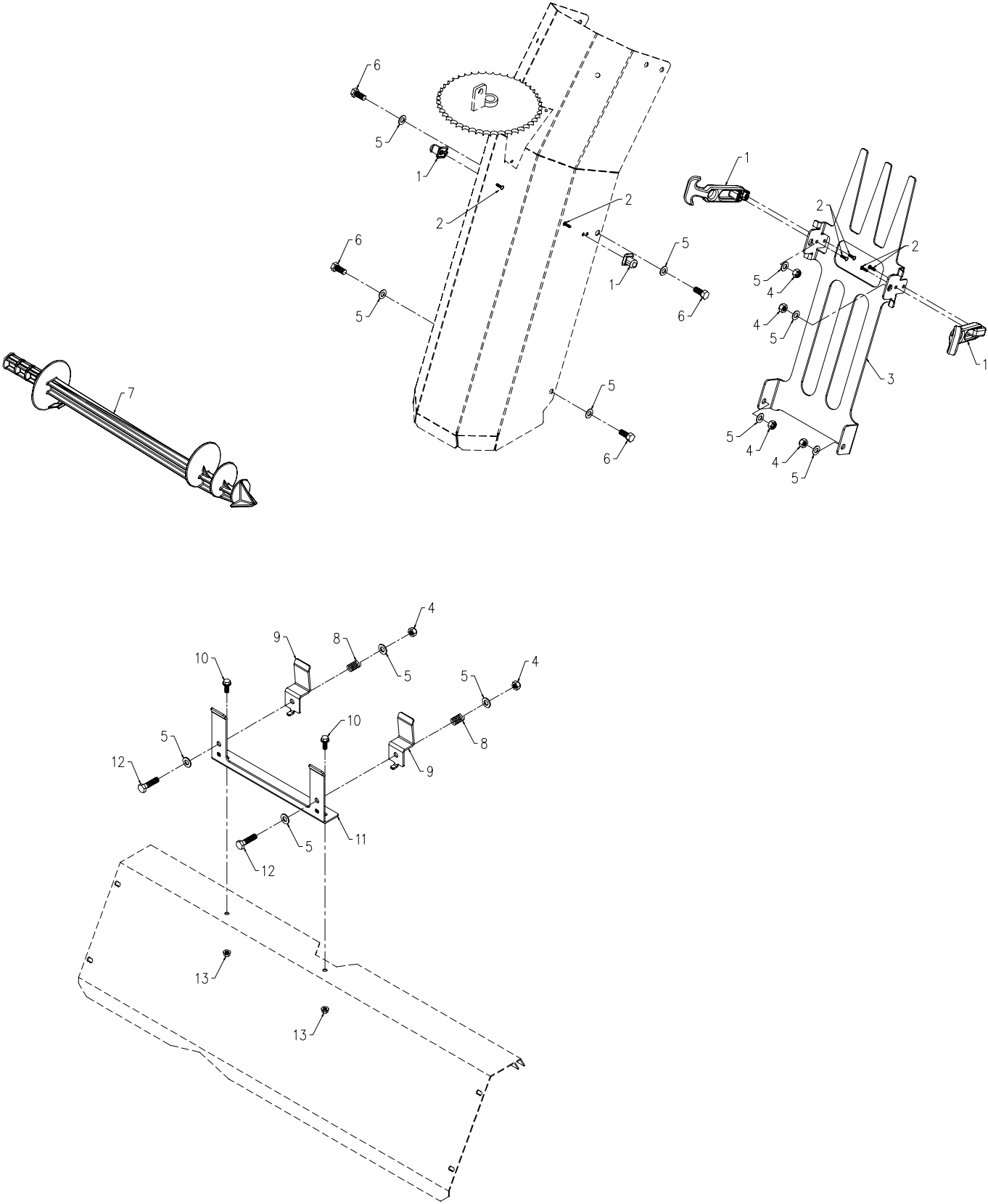

PARTS

Discharge Chute Guard & Cleaning Tool

REF.	PART NO.	DESCRIPTION	QTY.
1	47.0127	.LATCH, RUBBER DRAW T-HANDLE	2
2	99.K0072	.MACHINE SCREW, 10-24 X 1/2 ZP	6
3	60.1060	.GUARD, CHUTE DISCHARGE	1
4	99.A05	.LOCKNUT, STOVER 5/16-18 USS	6
5	95.05	.WASHER, FLAT 5/16 SAE	12
6	90.0506	.BOLT, 5/16-18 USS X 3/4	4
7	72.0023	.TOOL, CHUTE CLEANING	1
8	41.0039	.SPRING, COMP. 9/16 OD X 5/8	2
9	64.1482	.BRACKET, SNO-STIK DETENT	2
10	99.SF0405-1	.BOLT, SMF 1/4-20 X 5/8	2
11	64.1481	.BRACKET, SNO-STIK MOUNT	1
12	90.0510	.BOLT, 5/16-18 USS X 1 1/4	2
13	99.SF04	.NUT, SRF 1/4-20 USS	2

PARTS

ILLUSTRATED DRAWING Drive Shields

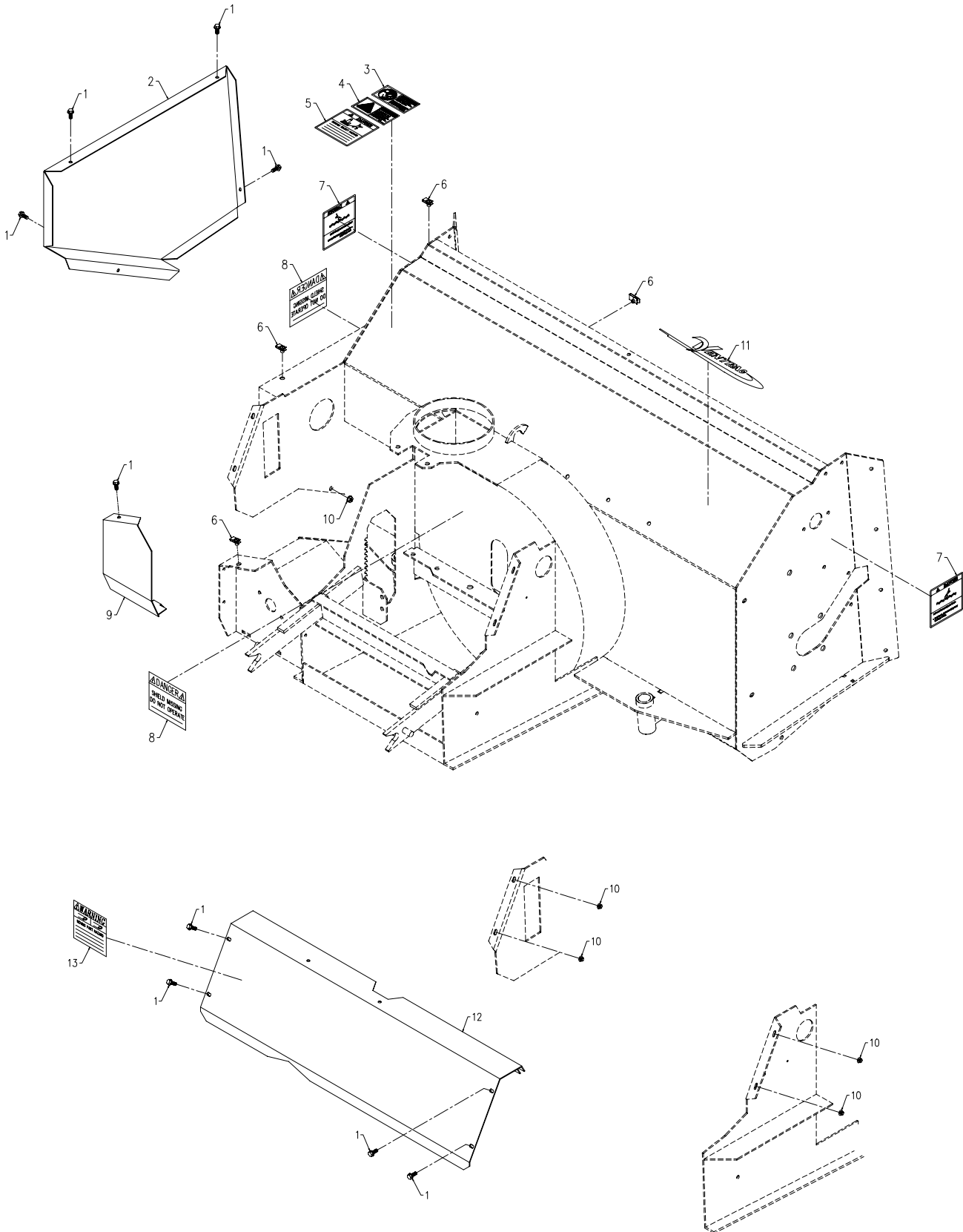

PARTS

Drive Shields

REF.	PART NO.	DESCRIPTION	QTY.
1	99.SF0405-1	.BOLT, SMF 1/4-20 X 5/8	9
2	60.0868	.SHIELD, AUGER DRIVE BELT	1
3	00.0217	.DECAL, WARNING READ OWNERS MAN	1
4	00.0220	.DECAL, GENERAL SAFETY	1
5	00.0122	.DECAL, THROWN OBJECT HAZARD	1
6	99.E0046	.NUT, "U" 1/4-20 EXTRUDED	3
7	00.0208	.DECAL, DANGER AUGER HAZARD	2
8	00.0062	.DECAL, DANGER SHIELD MISSING	2
9	60.0869	.SHIELD, DRIVE PULLEY COVER	1
10	99.SF04	.NUT, SRF 1/4-20 USS.	5
11	00.0189	.DECAL, VENTRAC ORBITAL	1
12	60.0871	.SHIELD, MAIN DRIVE COVER	1
13	00.0101	.DECAL, HAZARD-MOVING PART	1

PARTS

ILLUSTRATED DRAWING Skid Shoes, Cutting Edge, & Crossbar Guard

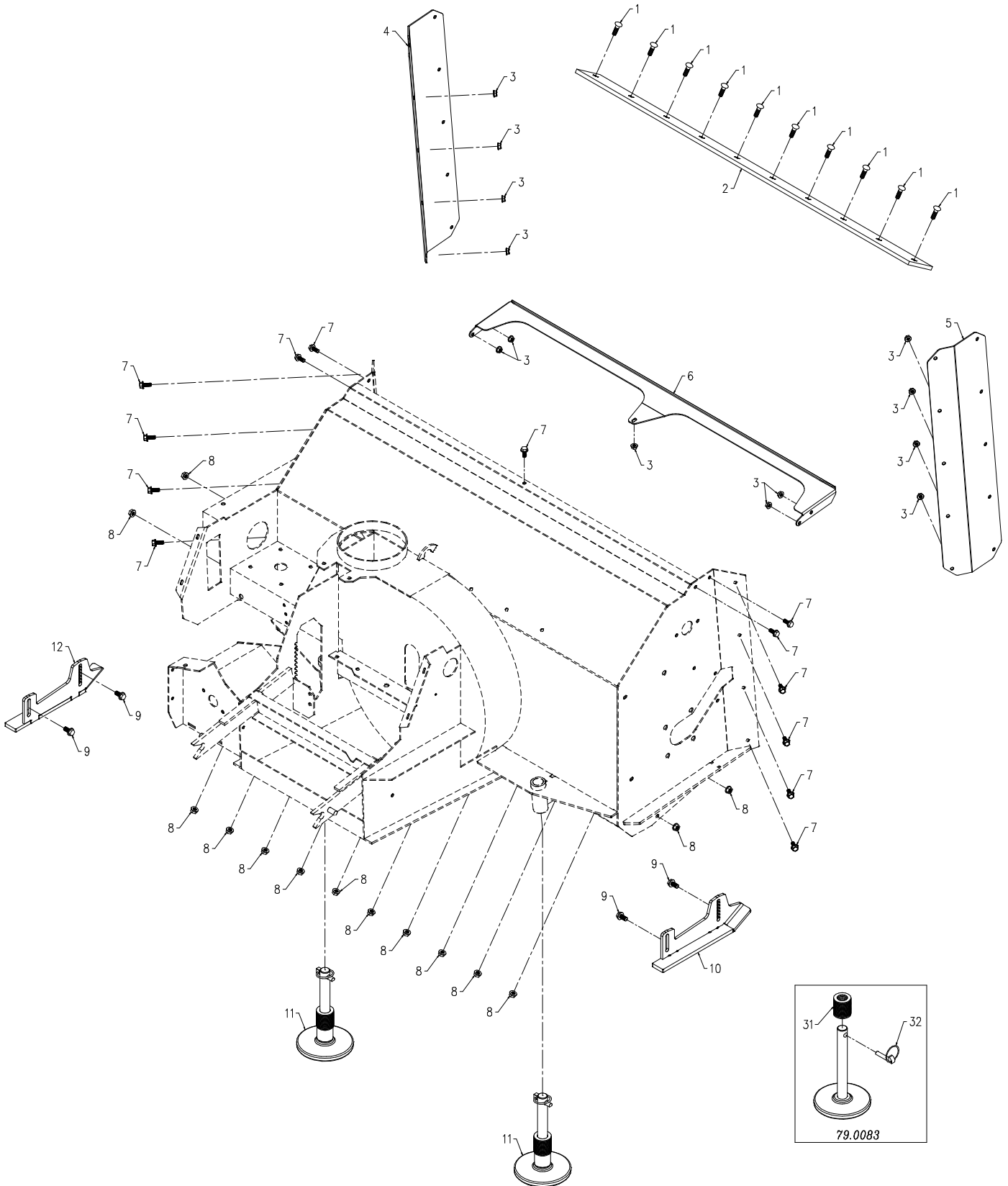

PARTS

Skid Shoes, Cutting Edge, & Crossbar Guard

REF.	PART NO.	DESCRIPTION	QTY.
1	97.0608	.BOLT, CARRIAGE 3/8 X 1	10
2	78.0054	.CUTTING EDGE, 47" THRU HARD	1
3	99.SF05	.NUT, SRF 5/16-18 USS	13
4	60.0878	.CUTTING EDGE, VERTICAL LEFT	1
5	60.0983	.CUTTING EDGE, VERTICAL RIGHT	1
6	60.1059	.GUARD, AUGER HSG CROSSBAR	1
7	99.SF0506	.BOLT, SRF 5/16-18 USS X 3/4	13
8	99.SF06	.NUT, SRF 3/8-16 USS	14
9	99.SF0606	.BOLT, SRF 3/8-16 USS X 3/4	4
10	64.1471	.SHOE, SKID FRONT RIGHT	1
11	79.0083	.SHOE, SKID ROUND ASM	2
12	64.1470	.SHOE, SKID FRONT LEFT	1
31	03.0005	.PIN, LYNCH	1
32	95.16	.WASHER, FLAT 1 SAE	19

PARTS

ILLUSTRATED DRAWING 70.8025 12 Volt Actuator

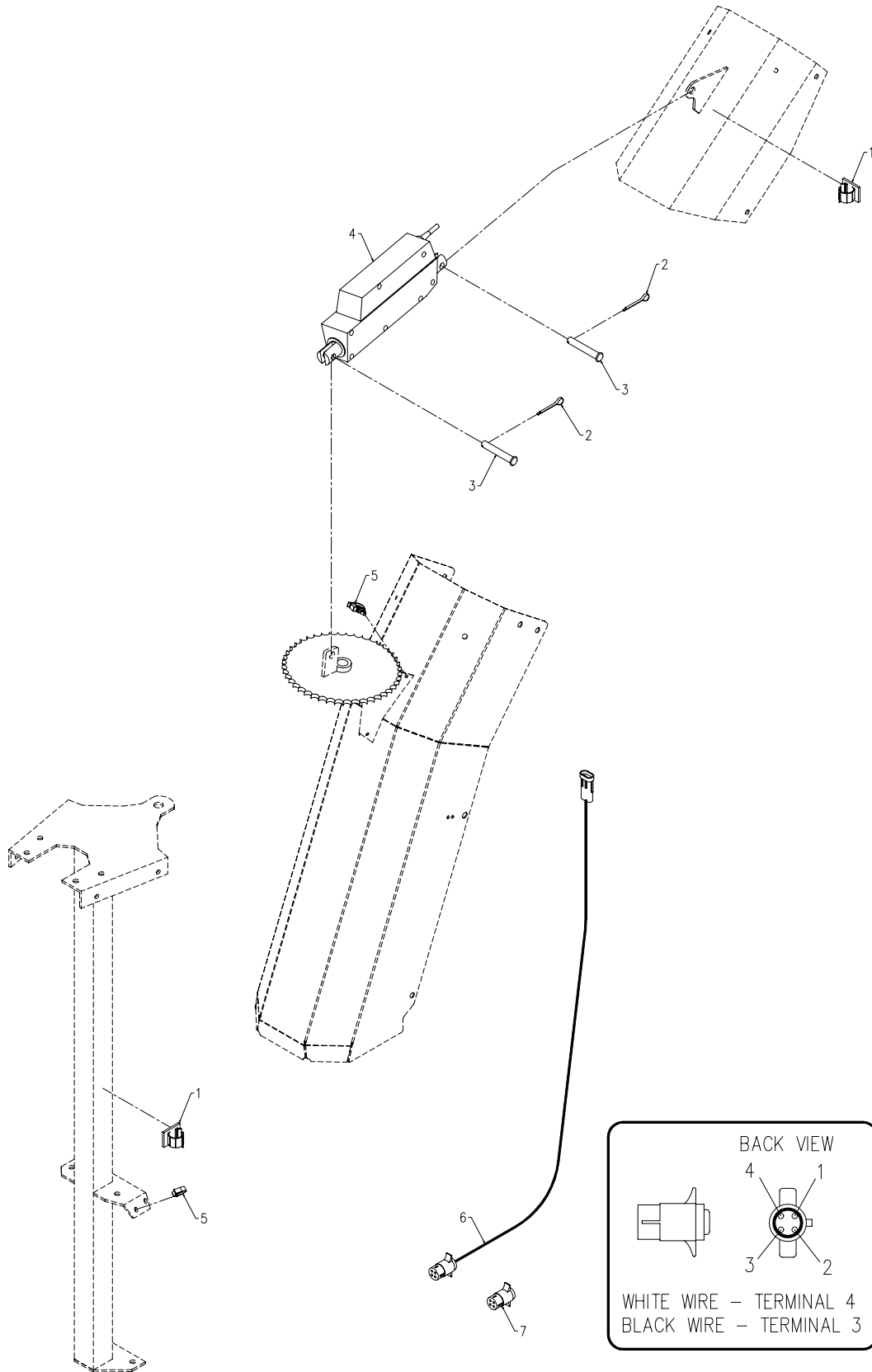

PARTS

70.8025 12 Volt Actuator

REF.	PART NO.	DESCRIPTION	QTY.
1	30.0226	.CLAMP, WIRE MT ADH. 3/8 GRAY	2
2	02.CP0306	.COTTER PIN, 3/32 X 3/4	2
3	03.0610	.CLEVIS PIN, 3/8 X 1 1/4 ZP	2
4	70.8025	.KIT, 12V ACTUATOR, HB/KX	1
5	30.0135	.CLAMP, LOOM 3/8 ROSEBUD MOUNT	2
6	32.0074	.HARNESS, 12 V ACTUATOR HB/KX	1
7	30.0218	.PLUG, TRAILER 4-PIN MALE	1

PARTS

ILLUSTRATED DRAWING 70.8072 Deep Snow Auger Kit

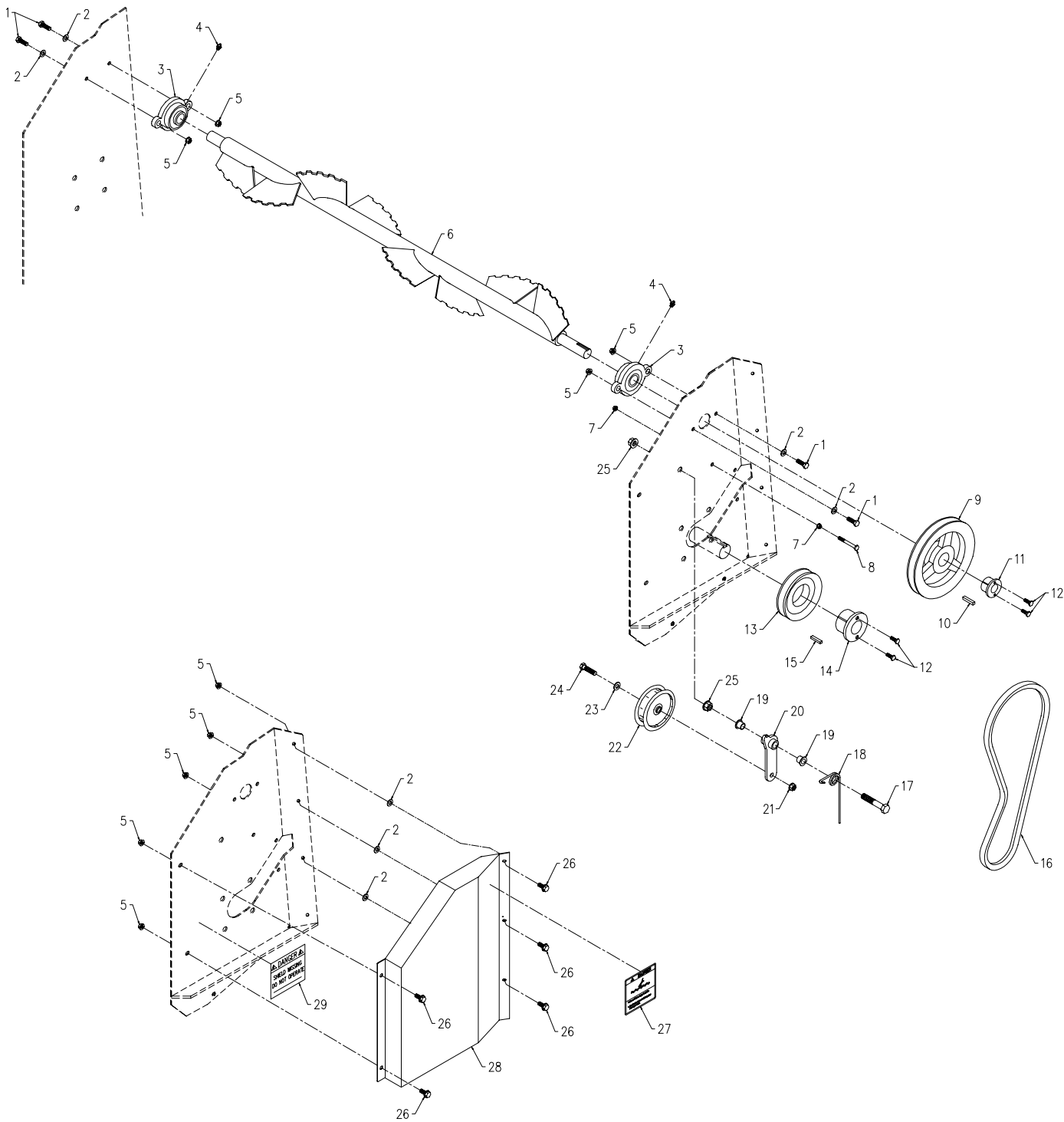

PARTS

70.8072 Deep Snow Auger Kit

REF.	PART NO.	DESCRIPTION	QTY.
1	90.0508	.BOLT, 5/16-18 USS X 1	4
2	95.05	.WASHER, FLAT 5/16 SAE	7
3	55.FB16016-1	.BEARING, FLANGE BLOCK 1"	2
4	29.GF0001	.GREASE FTG, 1/4 SAE ST	2
5	99.SF05	.NUT, SRF 5/16-18 USS	10
6	80.0370	.AUGER, TOP KX522	1
7	99.SF04	.NUT, SRF 1/4-20 USS	2
8	90.0418	.BOLT, 1/4-20 USS X 2 1/4	1
9	83.BK70H	.PULLEY, 7" H-BUSH	1
10	85.K0408	.KEY, 1/4 X 1	1
11	83.H16S	.BUSHING, 1" SPLIT 1/4" KEY	1
12	90.0406	.BOLT, 1/4-20 USS X 3/4	4
13	83.BK36H	.PULLEY, 3.6" H-BUSH	1
14	83.H23	.BUSHING, 1 7/16" H	1
15	85.K030410	.KEY, 3/16 X 1/4 X 1-1/4	1
16	81.B040	.BELT, B40	1
17	90.0822	.BOLT, 1/2-13 USS X 2 3/4	1
18	41.0083	.SPRING, TORSION RH 1-3/16 IDX7	1
19	85.B0027	.BUSHING, 1/2 ID X 5/8 OD X 5/8	2
20	40.0348	.ARM, TOP AUGER DRIVE BLT IDLER	1
21	99.SF06	.NUT, SRF 3/8-16 USS	1
22	83.0037	.PULLEY, IDLER FLAT 4" X 3/8	1
23	95.06	.WASHER, FLAT 3/8 SAE	1
24	90.0612	.BOLT, 3/8-16 USS X 1 1/2	1
25	99.SF08	.NUT, SRF 1/2-13 USS	2
26	99.SF0506	.BOLT, SRF 5/16-18 USS X 3/4	5
27	00.0208	.DECAL, DANGER AUGER HAZARD	1
28	60.0990	.SHIELD, TOP AUGER DRIVE BELT	1
29	00.0062	.DECAL, DANGER SHIELD MISSING	1

WARRANTY



LIMITED WARRANTY - VENTRAC COMMERCIAL EQUIPMENT

Venture Products, Inc., (henceforth referred to as V.P.I.) warrants on the terms and conditions herein, that it will repair, replace, or adjust any part manufactured by Venture Products Inc., and found by Venture Products, Inc., to be defective in material and/or workmanship during the applicable warranty term.

All Ventrac commercial equipment purchased and registered on or after January 1, 2019 will carry a 2-year commercial warranty. The warranty period begins on the date of original customer purchase:

Ventrac Commercial Equipment	Warranty Term
2100 SSV & Attachments	2-year
3000 Series Tractors & Attachments	2-year
4000 Series Tractors & Attachments	2-year

All Ventrac add-on kits and accessories such as: 3-point hitch, 12V front & rear power outlets, foot pedal, dual wheel kit, etc., will be covered under the above warranty periods provided they are installed by an Authorized Ventrac Dealer. This warranty may be transferred and will carry the remainder of the warranty starting from the original purchase/registration date with the dealership and/or V.P.I.

The engine warranty is covered by its respective engine manufacturer. Please refer to the engine manufacturer's warranty statement that is included in the owner's manual.

For warranty consideration on Ventrac commercial equipment, including any defective part, must be returned to an Authorized Ventrac Dealer within the warranty period. The warranty shall extend to the cost to repair or replace (as determined by V.P.I.) the defective part. The expense of pickup and delivery of equipment, service call drive time or any transportation expense incurred for warranty repair is the sole responsibility of the owner and is not covered under warranty by Ventrac and/or V.P.I. Ventrac and V.P.I.'s responsibility in respect to claims is limited to making the required repairs or replacements, and no claim of breach of warranty shall be cause for cancellation or rescission of the contract of sale of any Ventrac equipment. Proof of purchase may be required by the dealer to substantiate any warranty claim. Only warranty work performed and submitted by an Authorized Ventrac Dealer may be eligible for warranty credit.

This warranty extends only to Ventrac commercial equipment operated under normal conditions and properly serviced and maintained. The warranty expressly does NOT cover: (a) any defects, damage or deterioration due to normal use, wear and tear, or exposure; (b) normal maintenance services, such as cleaning, lubrication, oil change; (c) replacement of service items, such as oil, lubricants, spark plugs, belts, rubber hoses, bearings or other items subject to normal service replacement; (d) damage or defects arising out of, or relating to abuse, misuse, neglect, alteration, negligence or accident; (e) repair or replacement arising from operation of, or use of the equipment which is not in accordance with operating instructions as specified in the operator's manual or other operational instructions provided by V.P.I.; (f) repair or replacement arising as a result of any operation from Ventrac equipment that has been altered or modified so as to, in the determination of V.P.I., adversely affect the operation, performance or durability of the equipment or that has altered, modified or affected the equipment so as to change the intended use of the product; (g) repair or replacement necessitated by the use of parts, accessories or supplies, including gasoline, oil or lubricants, incompatible with the equipment or other than as recommended in the operator's manual or other operational instructions provided by V.P.I.; (h) repairs or replacements resulting from parts or accessories which have adversely affected the operation, performance or durability of the equipment; or (i) damage or defects due to or arising out of repair of Ventrac equipment by person or persons other than an authorized Ventrac service dealer or the installation of parts other than genuine Ventrac parts or Ventrac recommended parts.

WARRANTY



LIMITED WARRANTY - VENTRAC COMMERCIAL EQUIPMENT

The sole liability of V.P.I. with respect to this warranty shall be the repair and replacement as set forth herein. V.P.I. shall have no liability for any other cost, loss, or damage. In particular V.P.I. shall have no liability or responsibility for: (i) expenses relating to gasoline, oil, lubricants; (ii) loss, cost or expense relating to transportation or delivery of turf equipment from the location of owner or location where used by owner to or from any Authorized Ventrac Dealer; (iii) travel time, overtime, after hours' time or other extraordinary repair charges or charge relating to repairs or replacements outside of normal business hours at the place of business of an Authorized Ventrac Dealer; (iv) rental of like or similar replacement equipment during the period of any warranty repair or replacement work; (v) any telephone or telegram charges; (vi) loss or damage to person or property other than that covered by the terms of this warranty; (vii) any claims for lost revenue, lost profit or additional cost or expense incurred as a result of a claim of breach of warranty; or (viii) attorney's fees.

The remedies of buyer set forth herein are exclusive and are in lieu of all other remedies. The liability of V.P.I., whether in contract, tort, under any warranty, or otherwise, shall not extend beyond its obligation as set forth herein. V.P.I. shall not be liable for cost of removal or installation nor shall V.P.I. be responsible for any direct, indirect, special or consequential damages of any nature. In no event shall V.P.I. be liable for any sum in excess of the price received for the goods for which liability is claimed.

There are no representations or warranties which have been authorized to the buyer of the Ventrac commercial equipment other than set forth in this warranty. Any and all statements or representations made by any seller of this equipment, including those set forth in any sales literature or made orally by any sales representative, are superseded by the terms of this warranty. Any affirmation of fact or promise made by V.P.I. or any of its representatives to the buyer which relates to the goods that are the subject to this warranty shall not be regarded as part of the basis of the bargain and shall not be deemed to create any express warranty that such goods shall conform to the affirmation or promise.

No employee, distributor, or representative is authorized to change the foregoing warranties in any way or grant any other warranty on behalf of V.P.I.

Some states do not allow limitations on how long an implied warranty lasts or allow the exclusion on limitation of incidental or consequential damages, so the above limitation or exclusion may not apply to you.

This warranty gives you specific legal rights, and you may also have other rights which vary from state to state.

This warranty applies to all Ventrac commercial equipment sold by Venture Products Inc.