

Parts Manual

# KG540

Power Rake





500 Venture Drive  
Orrville Oh 44667  
www.ventrac.com

[View all manuals](#)



Visit [ventrac.com/manuals](http://ventrac.com/manuals) for the latest version of this parts manual. A downloadable operator's manual is also available.

### Serial Number Description

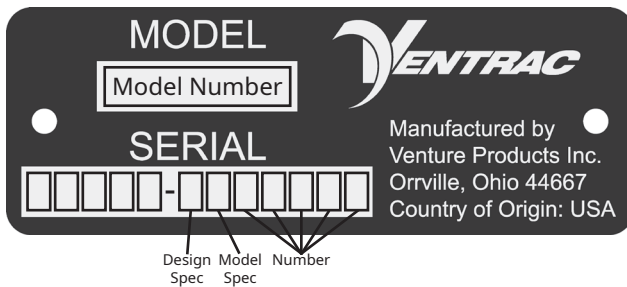

Serial Plate Location



### Notes

- If any component requires replacement, use only original Ventrac replacement parts.
- When ordering new components, be sure to order all required safety decals. All current safety decals must be affixed to the replacement components prior to installation of the component.

# TABLE OF CONTENTS

---

<b>PARTS</b>	<b>PAGE 4</b>
Main Frame .....	4
Carrier Frame and Wheels.....	6
Rotor Frame and Rotor .....	8
Hydraulic Rotor Drive.....	10
Hydraulic Pump Actuator .....	12
Rotor Pivot Frames.....	14
Rotor Height Adjustment .....	16
Rotor Angle Adjustment .....	18
Side Wings and Dirt Containment Flap.....	20

# PARTS

## ILLUSTRATED DRAWING Main Frame

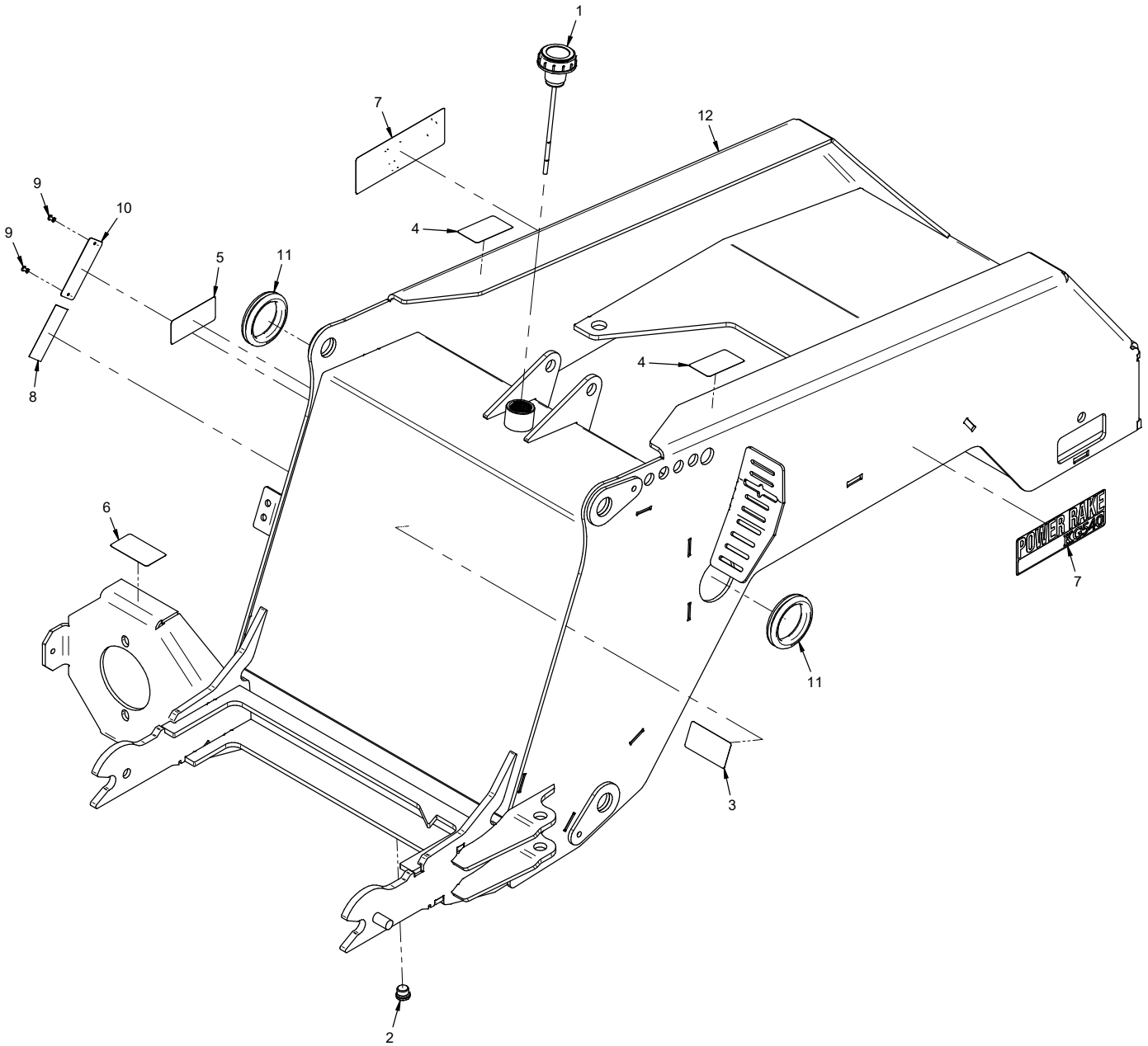

# PARTS

## Main Frame

REF.	PART NO.	DESCRIPTION	QTY.
1	23.0175	Dipstick, Asm 5-1/4	1
2	25.6408-H-06	Fitting, -06 MB x Hollow Allen	1
3	00.0374	Decal, Hot Surface	1
4	00.0364	Decal, Warning Pinch Point	2
5	00.0621	Decal, High Pressure Fluid Hazard	1
6	00.0631	Decal, Finger/Hand Entanglement	1
7	00.0673	Decal, KG540	2
8	00.0100	Decal, Built in the USA	1
9	04.0003	Rivet, Pop 1/8 X 3/8 SS	2
10	N/A	Plate, Ventrac Serial Number	1
11	05.0073	Grommet, 2 ID, 2-3/4 OD 9/16 T	2
12	KG-6003	Frame, Hitch / Hydraulic Tank	1

# PARTS

## ILLUSTRATED DRAWING Carrier Frame and Wheels

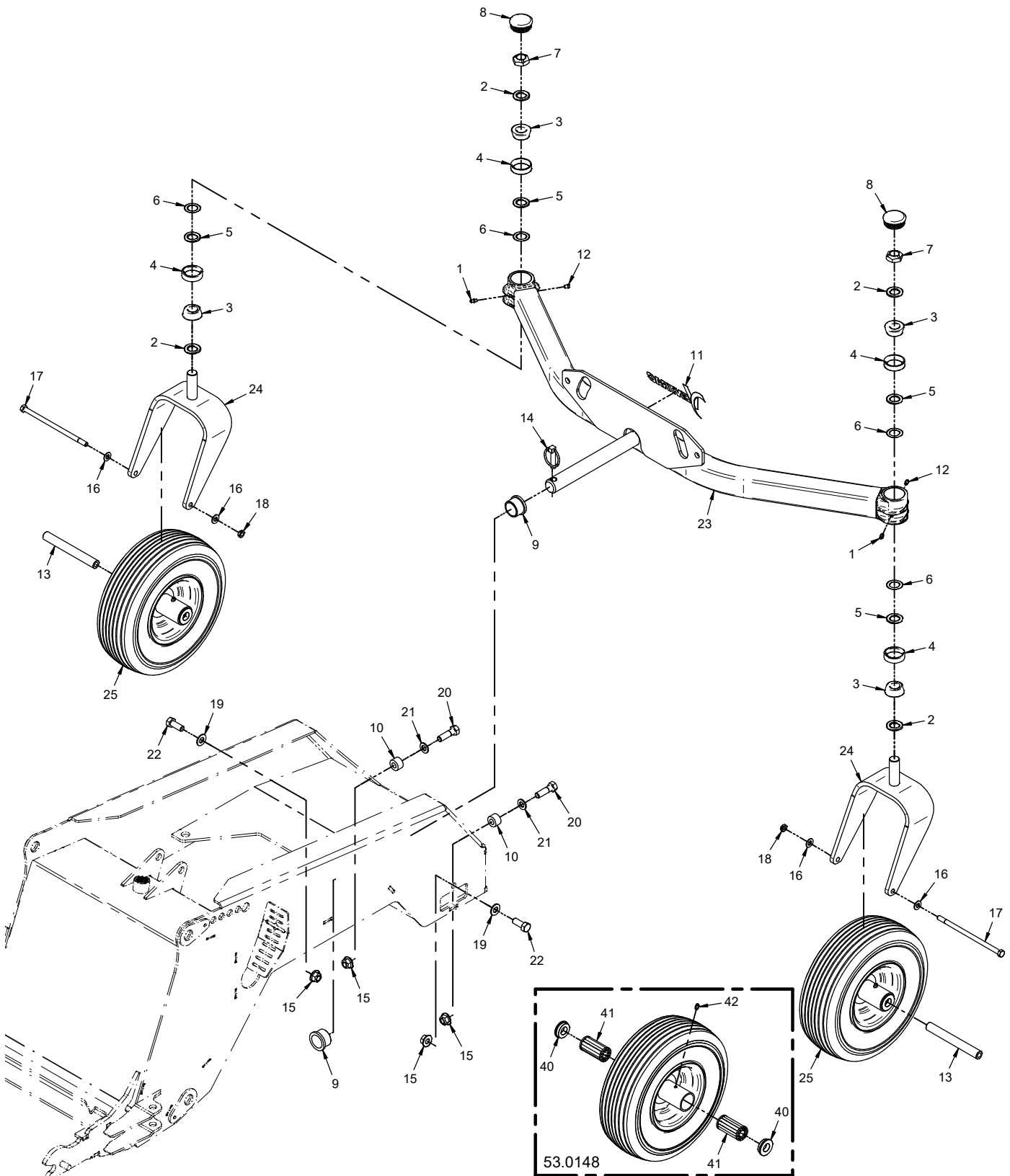

# PARTS

## Carrier Frame and Wheels

REF.	PART NO.	DESCRIPTION	QTY.
1	29.GF0001	.Grease Ftg, 1/4 SAE ST	2
2	99.B0119	.Washer, Mach 7/8 x 1-3/8 x 10 GA	4
3	55.LM12749LA2	.Bearing, Taper Roller Cone	4
4	55.LM12710	.Bearing, Cup	4
5	85.B0099	.Bushing, .875ID x 1.375OD x .120T	4
6	85.B0101	.Bushing, .005 Spacer	4
7	99.M0047	.Locknut, Stover M22 X 1.5 ZP	2
8	05.0172	.Plug, Ribbed Black LDPE	2
9	85.B0060	.Bushing, 1-1/4 ID x 1-1/2 OD 1	2
10	KG-1112	.Bushing, Wheel Frame Stop	2
11	00.0672	.Decal, Ventrac Black	1
12	29.GF0011	.Grease Ftg, Plug 1/4-28	2
13	50.0050	.Tube, Swivel Axle	2
14	03.0005	.Pin, Linch	1
15	99.E0103	.Nut, Locking Flange 1/2-13	4
16	95.06	.Washer, Flat 3/8 SAE	4
17	90.0660	.Bolt, 3/8-16 USS x 7-1/2	2
18	99.A06C	.Locknut, Center 3/8-16	2
19	95.08	.Washer, Flat 1/2 SAE	2
20	90.0814	.Bolt, 1/2-13 USS x 1-3/4	2
21	99.M0072	.Washer, Flat M12	2
22	90.0810	.Bolt, 1/2-13 USS x 1-1/4	2
23	KG-6008	.Frame, Carrier	1
24	50.0195	.Yoke, Caster 13" Wheel	2
25	53.0148	.Wheel, Asm 13x5x6 Rib Flatfree	2
40	55.0072	.Bearing, Retainer 3/4"	2
41	55.0088	.Bearing, Roller Replacement	2
42	29.GF0001	.Grease Ftg, 1/4 SAE ST	1

# PARTS

## ILLUSTRATED DRAWING Rotor Frame and Rotor

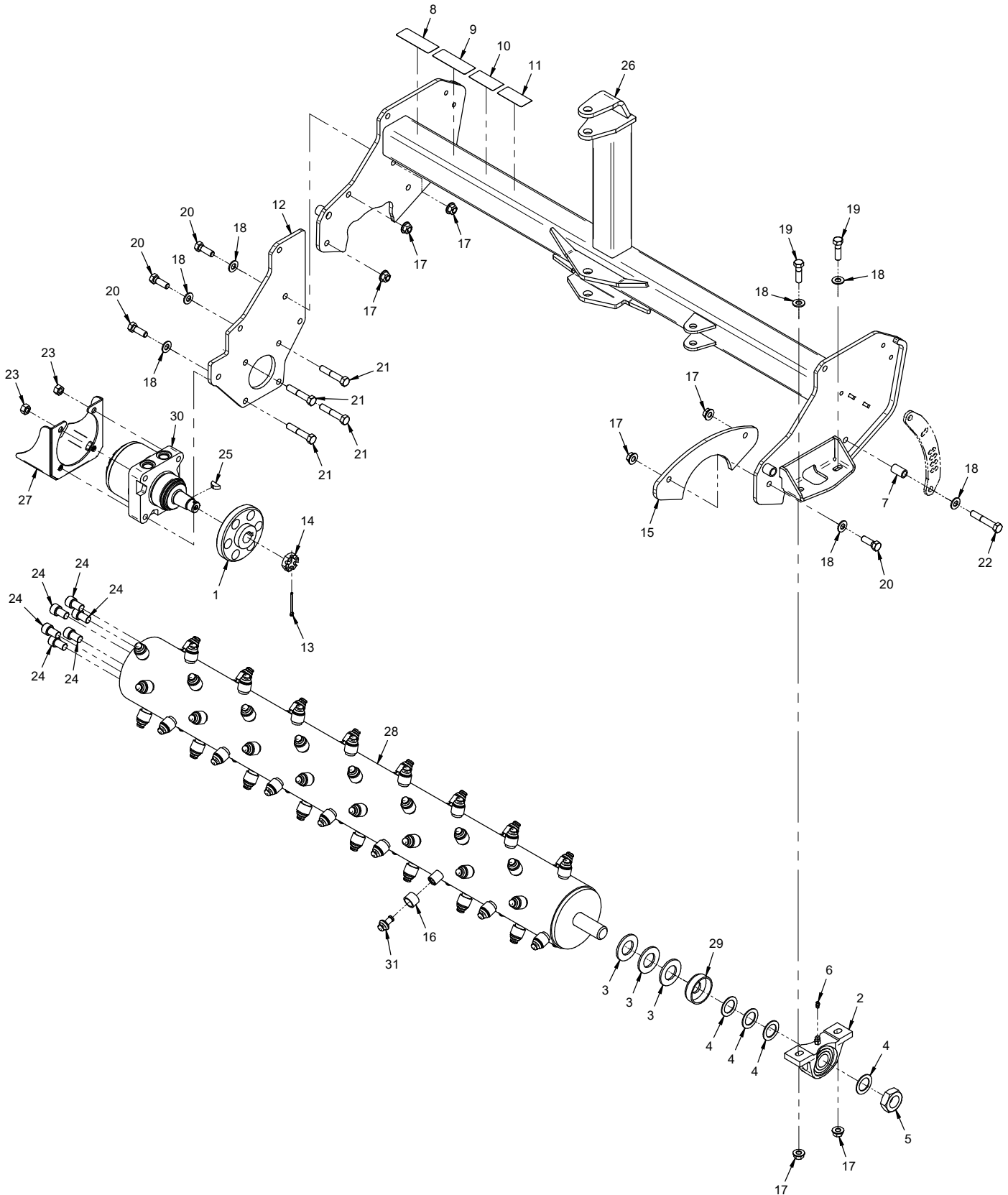



# PARTS

## Rotor Frame and Rotor

REF.	PART NO.	DESCRIPTION	QTY.
1	KG-1108	Hub, Rotor Drive	1
2	55.PB25020	Bearing, Pillow Block, 1-1/4	1
3	95.20	Washer, Flat 1-1/4 SAE	3
4	99.B0078	Washer, Mach, 1 1/4 , 14 GA	4
5	99.E0152	Nut, Jam 1-1/4 - 12 USS	1
6	29.GF0001	Grease Ftg, 1/4 SAE ST	1
7	KG-1068	Spacer, Wing Guide Right.	1
8	00.0620	Decal, Pinching or Crushing Hazard.	1
9	00.0675	Decal, Entanglement Hazard.	1
10	00.0674	Decal, Thrown Objects	1
11	00.0619	Decal, Read Operator's Manual.	1
12	KG-1083	Plate, Hyd Motor Mount.	1
13	02.CP0516	Cotter Pin, 5/32 x 2	1
14	99.E0069	Nut, Castle 1"-20 UNEF	1
15	KG-1024	Plate, Rotor End Cover	1
16	64.1999	Sleeve, Protective	72
17	99.E0103	Nut, Locking Flange 1/2-13	7
18	95.08	Washer, Flat 1/2 SAE	7
19	90.0814	Bolt, 1/2-13 USS x 1-3/4	2
20	90.0812	Bolt, 1/2-13 USS x 1-1/2	4
21	90.0822	Bolt, 1/2-13 USS x 2-3/4	4
22	90.0824	Bolt, 1/2-13 USS x 3	1
23	92.08	Nut, 1/2-13 USS	2
24	99.K0088	Bolt, SHCS 5/8-18 x 1 Grade 8	6
25	85.W0508	Key, Woodruff 5/16 x 1	1
26	KG-6004	Frame, Rotor Mount	1
27	KG-6017	Guard, Hyd Motor	1
28	KG-6019	Rotor, Drum	1
29	64.1014	Shield, Bearing Dirt Cover	1
30	21.0125	Motor, Hyd. Parker 238CC	1
31	79.0052	Tooth, Carbide 8620 Case Hard.	72

# PARTS

## ILLUSTRATED DRAWING Hydraulic Rotor Drive

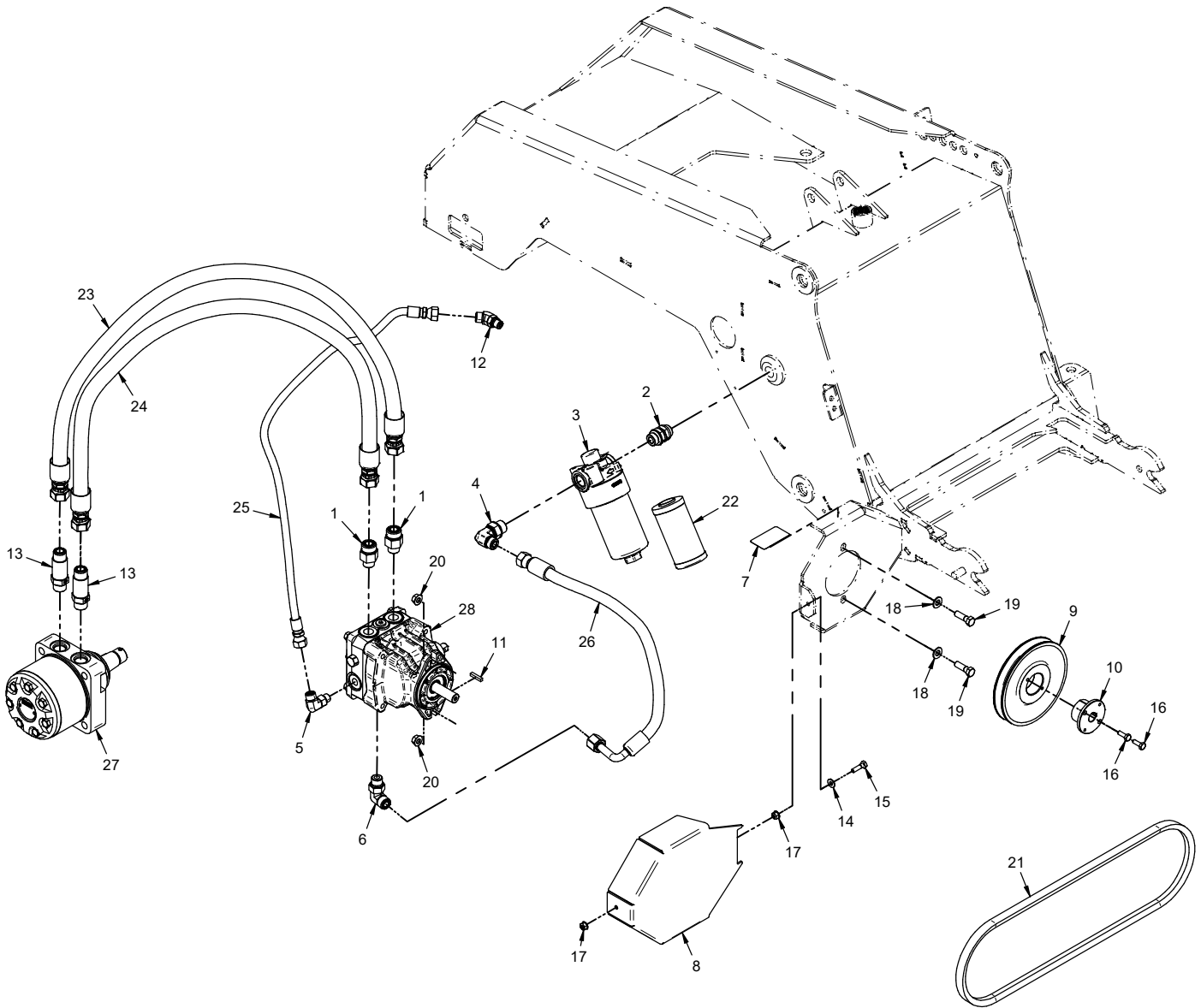

# PARTS

## Hydraulic Rotor Drive

REF.	PART NO.	DESCRIPTION	QTY.
1	25.FF6400-10-08	Fitting, Connector -10MF x -08MB	2
2	25.6407-10-10	Fitting, M. Adapter -10 X -10	1
3	21.0137	Filter, HYD ASM 25 Micron	1
4	25.FF6801-08-10	Fitting, 90 Elbow 08MFF x 10MB	1
5	25.FF6801-06-06	Fitting, 90 Elbow - 6MFF X 6MB	1
6	25.FF6801-08-08	Fitting, 90 Elbow 8MFF x 8MB	1
7	00.0631	Decal, Finger/Hand Entanglement	1
8	KG-1089	Cover, Drive Pulley	1
9	83.BK65H	Pulley, 6.5" H-Bushing	1
10	83.H17M	Bushing, 17mm H	1
11	85.K508	Key, 5mm Sq x 1"	1
12	25.FF6802-06-06	Fitting, 45 Elbow - 6Mff X 6Mb	1
13	25.FF6400-L-10-10	Fitting, Connector Long -10MF x -10MB	2
14	95.04	Washer, Flat 1/4 SAE	1
15	90.0408	Bolt, 1/4-20 USS x 1	1
16	90.0406	Bolt, 1/4-20 USS x 3/4"	2
17	99.E0101	Nut, Locking Flange 1/4-20	2
18	95.06	Washer, Flat 3/8 SAE	2
19	90.0610	Bolt, 3/8-16 USS x 1-1/4	2
20	99.SF06	Nut, SRF 3/8-16 USS	2
21	81.B052	Belt, B52R	1
22	21.0138	Filter, Hyd Element 25 Micron	1
23	20.0407	Hose, 3/4x34.00 SAE 100R17AR	1
24	20.0407	Hose, 3/4x34.00 SAE 100R17AR	1
25	20.0411	Hose, 1/4x38.00 SAE 100R17AR	1
26	20.0412	Hose, 1/2x21.00 SAE 100R17AR	1
27	21.0125	Motor, Hyd. Parker 238CC	1
28	21.0145	Pump, Hyd. Hydrogear	1

# PARTS

## ILLUSTRATED DRAWING Hydraulic Pump Actuator

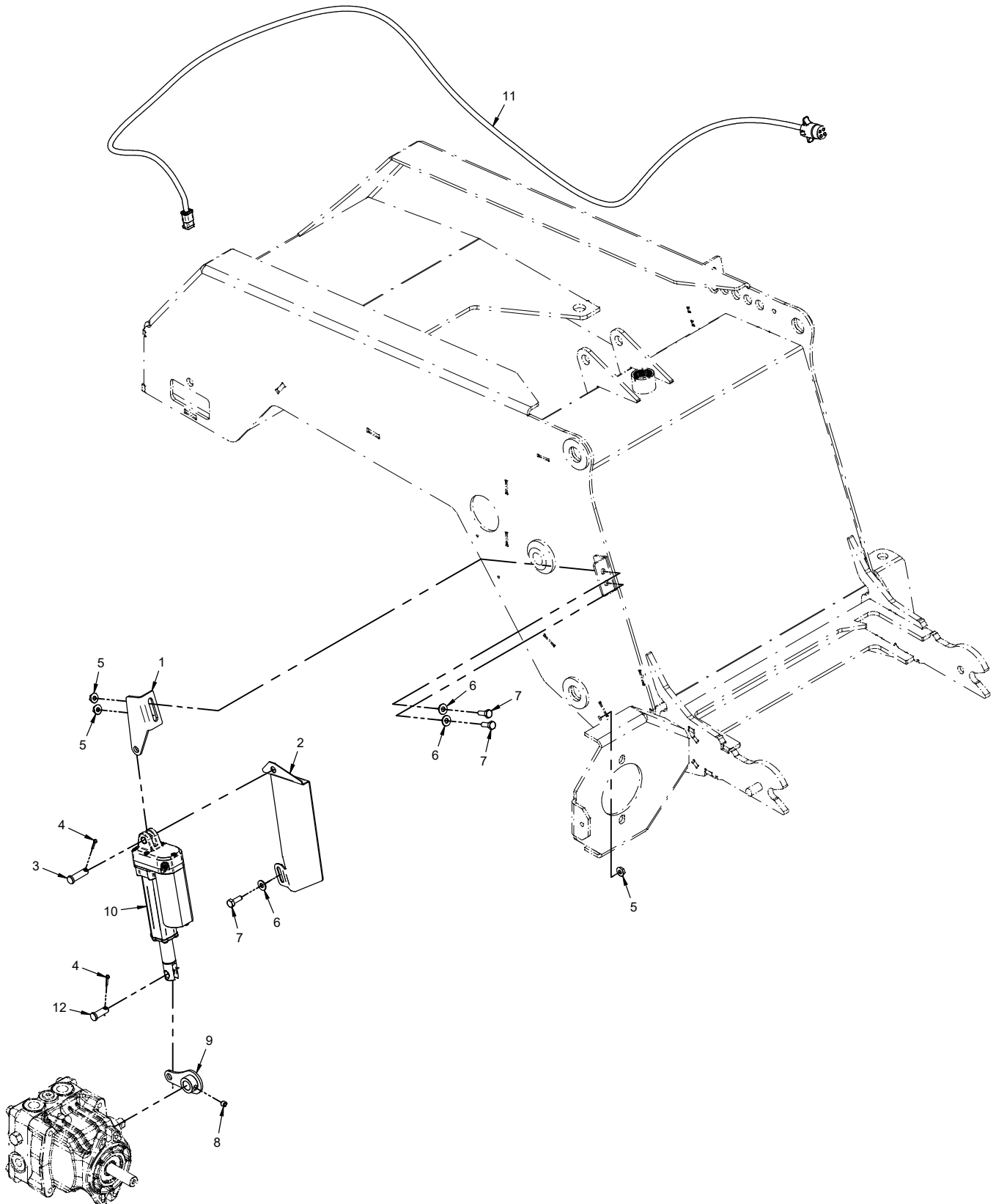

# PARTS

## Hydraulic Pump Actuator

REF.	PART NO.	DESCRIPTION	QTY.
1	KG-1094	Mount, Pump Actuator	1
2	KG-1121	Shield, Actuator Heat	1
3	03.0610	Clevis Pin, 3/8 X 1 1/4 Zp	1
4	02.CP0306	Cotter Pin, 3/32 X 3/4	2
5	99.SF04	Nut, SRF 1/4-20 USS	3
6	95.04	Washer, Flat 1/4 SAE	3
7	90.0406	Bolt, 1/4-20 USS x 3/4"	3
8	85.SS29	Set Screw, 5/16-24 x 1/4" SS	1
9	KG-6018	Lever, Pump Control	1
10	37.0070	Actuator, 12V 35mm Stroke	1
11	32.0211	Harness, Wire Actuator	1
12	03.0608	Clevis Pin, 3/8 x 1	1

# PARTS

## ILLUSTRATED DRAWING Rotor Pivot Frames

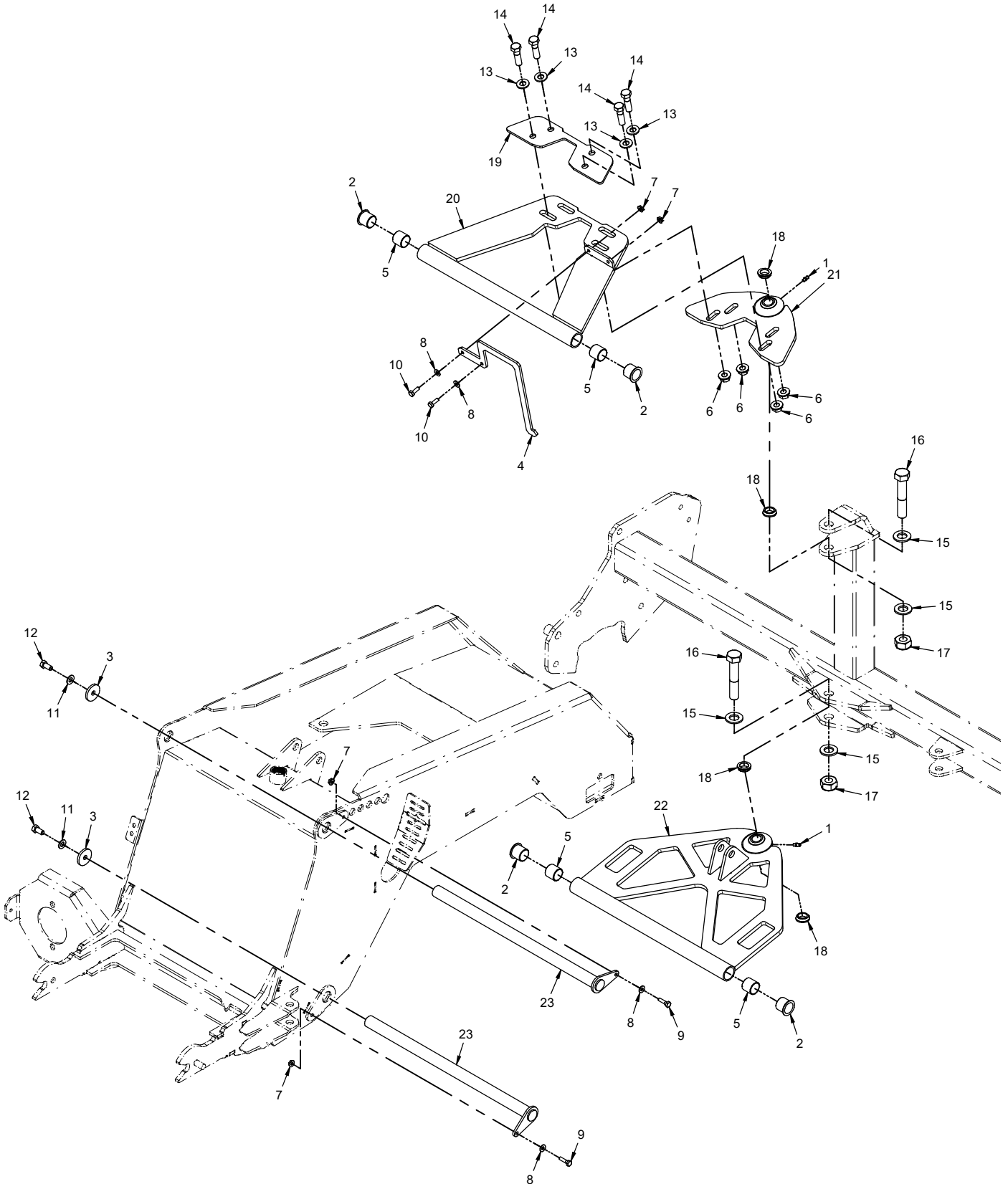

# PARTS

## Rotor Pivot Frames

REF.	PART NO.	DESCRIPTION	QTY.
1	29.GF0001	.Grease Ftg, 1/4 SAE ST	2
2	85.B0102	.Bushing, 1.000 ID x 1.125 OD x 1 L	4
3	KG-1098	.Washer, Pivot Rod Retainer	2
4	KG-1095	.Arm, Height Indicator	1
5	85.B0104	.Bushing, 1.000 ID x 1.125 OD x 1 L	4
6	99.E0103	.Nut, Locking Flange 1/2-13	4
7	99.SF04	.Nut, SRF 1/4-20 USS	4
8	95.04	.Washer, Flat 1/4 SAE	4
9	90.0408	.Bolt, 1/4-20 USS x 1	2
10	90.0406	.Bolt, 1/4-20 USS x 3/4"	2
11	95.06	.Washer, Flat 3/8 SAE	2
12	90.0606	.Bolt, 3/8-16 USS x 3/4	2
13	95.08	.Washer, Flat 1/2 SAE	4
14	90.0814	.Bolt, 1/2-13 USS x 1-3/4	4
15	95.12	.Washer, Flat 3/4 SAE	4
16	90.1232	.Bolt, 3/4-10 USS x 4	2
17	99.E0115	.Nut, Jam 3/4-10 Nylon Lock Wid	2
18	43.SP12-1WS	.Spacer. Rod End 3/4" Washer Style	4
19	KG-1122	.Plate, Upper Rotor Pivot	1
20	KG-6006	.Frame, Upper Rotor Pivot	1
21	KG-6012	.Mount, Upper Swivel	1
22	KG-6002	.Frame, Lower Rotor Pivot	1
23	KG-6011	.Pin, Pivot Anchor	2

# PARTS

## ILLUSTRATED DRAWING Rotor Height Adjustment

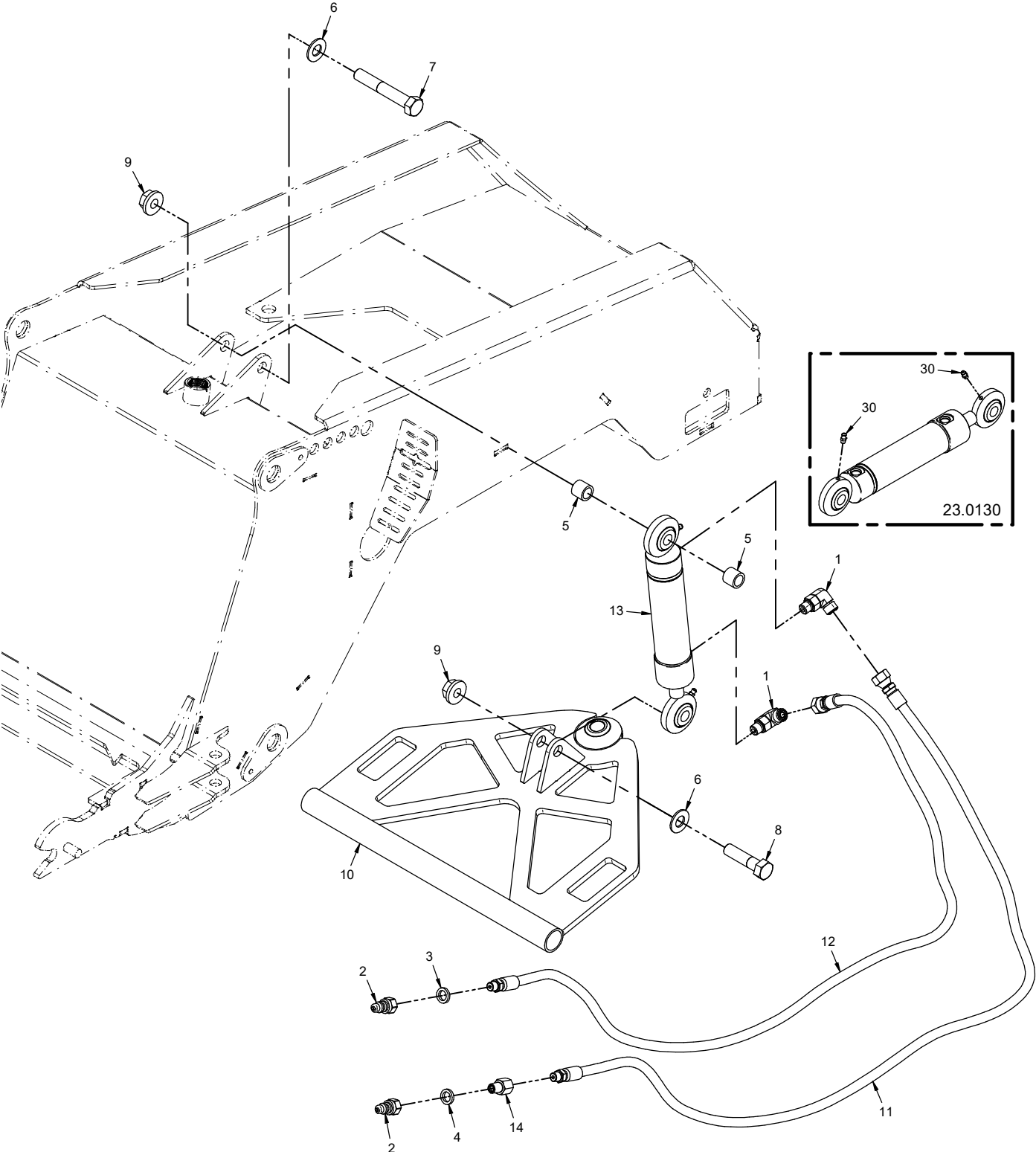



# PARTS

## Rotor Height Adjustment

REF.	PART NO.	DESCRIPTION	QTY.
1	25.FF6801-06-06	Fitting, 90 Elbow - 6MFF X 6MB	2
2	23.0104	Coupler, Quick Male 1/4	2
3	05.0156	Washer, .544 ID x .817 x .14 Nat	1
4	05.0157	Washer, .544 ID x .817 x .14 Blk	1
5	KG-1091	Spacer, Height Adjust Cylinder	2
6	95.10	Washer, Flat 5/8 SAE	2
7	90.1032	Bolt, 5/8-11 USS x 4	1
8	90.1020	Bolt, 5/8-11 USS x 2-1/2	1
9	99.E0094	Locknut, 5/8-11 Flanged Stover	2
10	KG-6002	Frame, Lower Rotor Pivot	1
11	20.0408	Hose, 1/4x48.00 SAE 100R17AR	1
12	20.0408	Hose, 1/4x48.00 SAE 100R17AR	1
13	23.0130	Cylinder, 1-1/2" X 5"	1
14	29.0092	Fitting, .025 Orifice 1/4 Pipe	1
30	29.GF0001	Grease Ftg, 1/4 SAE ST	2

# PARTS

## ILLUSTRATED DRAWING Rotor Angle Adjustment

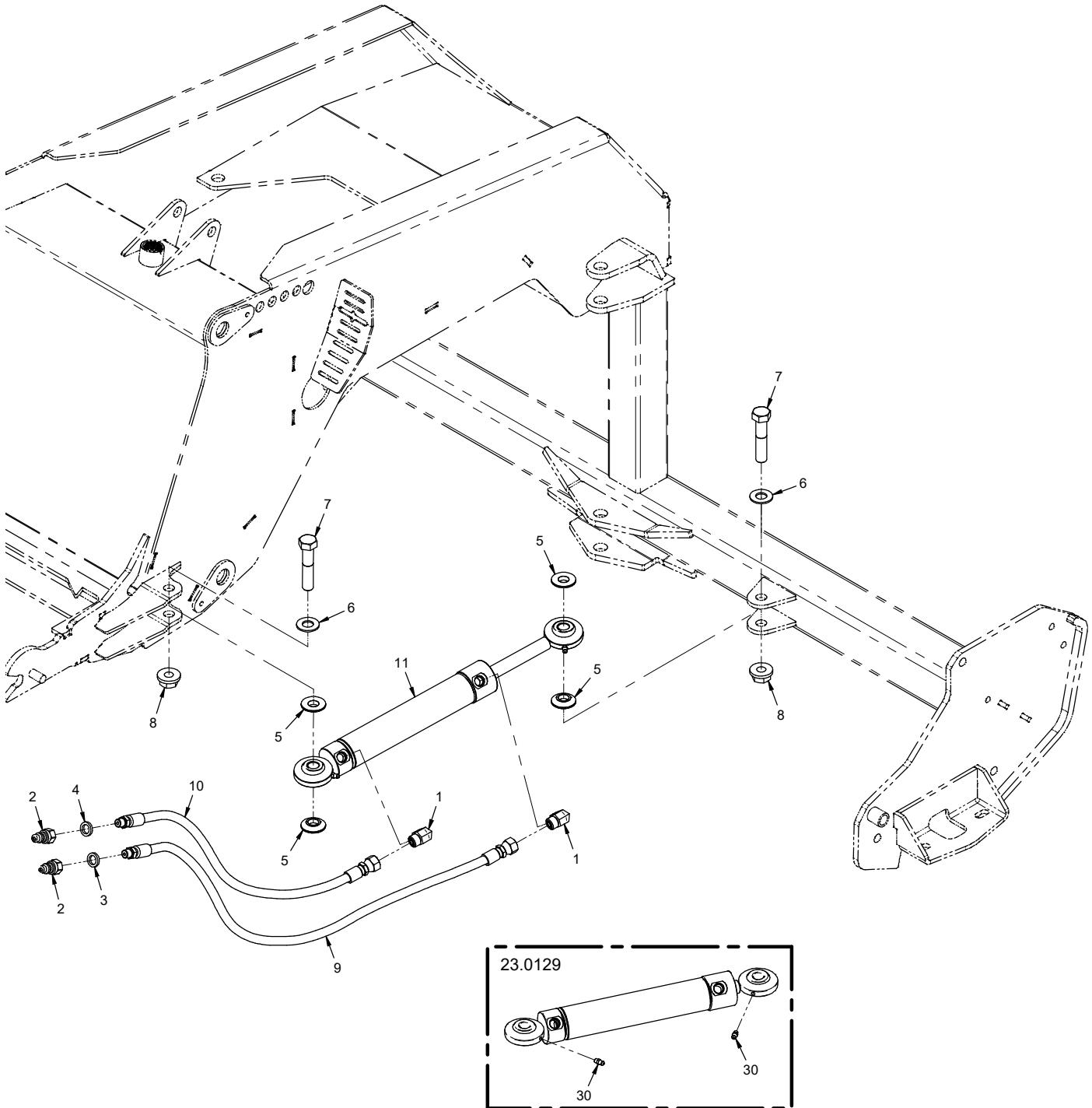

# PARTS

## Rotor Angle Adjustment

REF.	PART NO.	DESCRIPTION	QTY.
1	25.FF6801-06-06	Fitting, 90 Elbow - 6MFF X 6MB	2
2	23.0104	Coupler, Quick Male 1/4	2
3	05.0117	Washer, .544 ID x .817 x .14 Yel.	1
4	05.0116	Washer, .544 ID x .817 x .14 Red	1
5	43.SP10WS	Spacer, Rod End 5/8" Washer Style	4
6	95.10	Washer, Flat 5/8 SAE	2
7	90.1024	Bolt, 5/8-11 USS x 3	2
8	99.E0094	Locknut, 5/8-11 Flanged Stover	2
9	20.0409	Hose, 1/4x38.00 SAE 100R17AR	1
10	20.0410	Hose, 1/4x28.00 SAE 100R17AR	1
11	23.0129	Cylinder, 1-1/2" X 8" Steering	1
30	29.GF0001	Grease Ftg, 1/4 SAE ST	2

# PARTS

## ILLUSTRATED DRAWING Side Wings and Dirt Containment Flap

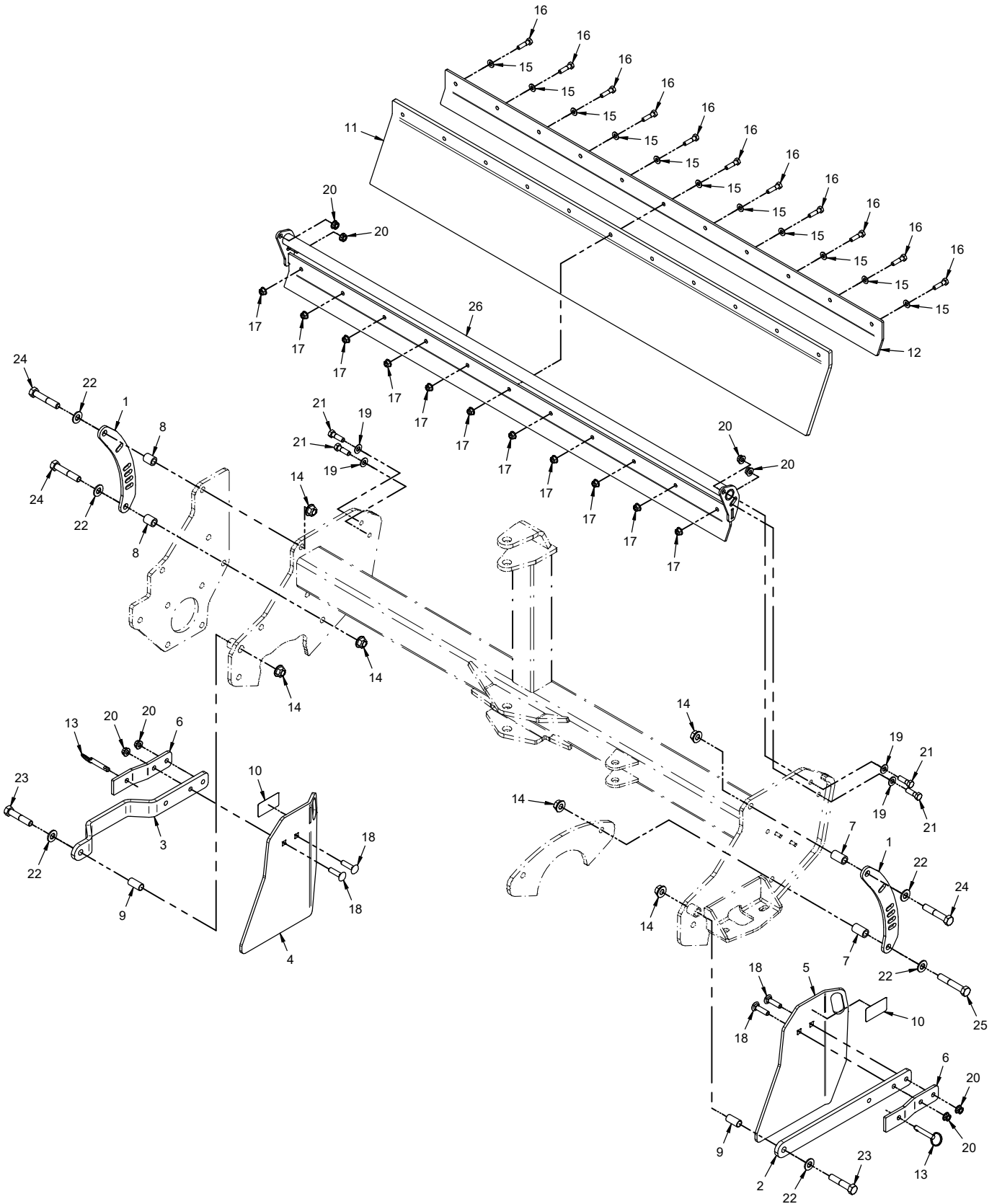

# PARTS

## Side Wings and Dirt Containment Flap

REF.	PART NO.	DESCRIPTION	QTY.
1	KG-1064	Guide, Side Wing	2
2	KG-1069	Arm, Right Side Wing	1
3	KG-1065	Arm, Left Side Wing	1
4	KG-1018	Wing, Left Side	1
5	KG-1019	Wing, Right Side	1
6	KG-1066	Plate, Side Wing Lock	2
7	KG-1068	Spacer, Wing Guide Right	2
8	KG-1114	Spacer, Wing Guide Left	2
9	KG-1067	Bushing, Wing Arm Pivot	2
10	00.0364	Decal, Warning Pinch Point	2
11	KG-1072	Flap, Front Dirt	1
12	KG-1071	Clamp, Front Belting	1
13	03.0010	Pin, Ball 3/8 X 1-1/2	2
14	99.E0103	Nut, Locking Flange 1/2-13	6
15	95.05	Washer, Flat 5/16 SAE	11
16	90.0510	Bolt, 5/16-18 USS x 1-1/4	11
17	99.E0102	Nut, Locking Flange 5/16-18	11
18	97.0612	Bolt, Carriage 3/8-16 x 1 1/2	4
19	95.06	Washer, Flat 3/8 SAE	4
20	99.E0082	Nut, Locking Flange 3/8-16	8
21	90.0610	Bolt, 3/8-16 USS x 1-1/4	4
22	95.08	Washer, Flat 1/2 SAE	6
23	90.0820	Bolt, 1/2-13 USS x 2-1/2	2
24	90.0822	Bolt, 1/2-13 USS x 2-3/4	3
25	90.0824	Bolt, 1/2-13 USS x 3	1
26	KG-6016	Frame, Front Dirt Flap	1