



*Operator's Manual
& Parts Drawings*

DG550

Ballpark Renovator

Europe C€





500 Venture Drive
Orrville Oh 44667
www.ventrac.com

View all manuals



Visit ventrac.com/manuals for the latest version of this operator's manual.

A downloadable parts manual is also available.

To the Owner Contact Information and Product Identification

If you need to contact an authorized Ventrac dealer for information on servicing your product, always provide the product model and serial numbers.

Please fill in the following information for future reference. See the picture(s) below to find the location of the identification numbers. Record them in the spaces provided.

Date of Purchase: _____

Dealer: _____

Dealer Address: _____

Dealer Phone Number: _____

Dealer Fax Number: _____

Model # (A): _____ Serial # (B): _____ <p style="text-align: center;">Affix Part/Serial Number label here.</p>
--

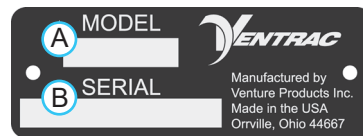

Venture Products Inc. reserves the right to make changes in design or specifications without obligation to make like changes on previously manufactured products.

TABLE OF CONTENTS

INTRODUCTION	PAGE 5
Product Description.....	5
Why Do I Need an Operator’s Manual?	5
Using Your Manual	6
Manual Glossary	6
SAFETY	PAGE 7
Safety Decals	7
General Safety Procedures.....	8
Training Required.....	8
Personal Protective Equipment Requirements	8
Operation Safety	8
Preventing Accidents.....	9
Keep Riders Off.....	9
Operating On Slopes.....	10
Roadway Safety	10
Truck Or Trailer Transport	10
Maintenance.....	11
Fuel Safety	11
Hydraulic Safety	12
OPERATIONAL CONTROLS	PAGE 14
Renovator Blades.....	14
Scarifier Spring Tines	14
Leveling Bar	14
GENERAL OPERATION	PAGE 15
Daily Inspection.....	15
Attaching	15
Detaching	15
Operating Procedures and Tips	15
SERVICE	PAGE 18
Cleaning and General Maintenance.....	18
Tire Pressure.....	18
Scarifier Spring Tine Replacement.....	18
Renovator Blade Replacement	18
Lubrication Locations	18
Storage.....	19
Maintenance Schedule.....	20
Maintenance Checklist.....	20
SPECIFICATIONS	PAGE 21
Dimensions	21
Features	21
EC Declaration of Conformity.....	21

TABLE OF CONTENTS

PARTS	PAGE 22
Main Frame & Front Wheels	22
Renovator Blades.....	24
Hydraulic Height Adjust.....	26
Scarifier Tines	28
Leveling Bar	30
70.4137 Mid Weight Bar 4500 Kit	32
WARRANTY	PAGE 34

INTRODUCTION



Venture Products Inc. is pleased to provide you with your new Ventrac DG550 ballpark renovator! We hope that Ventrac equipment will provide you with a ONE Tractor Solution.

Listed below are just some of the items that can provide you *versatility* as you use your DG550 ballpark renovator. Please visit our website, or contact your authorized Ventrac dealer for a complete list of items available for your new ballpark renovator.

Scan the QR code or visit <http://ventrac.com/QR/groomer> for an operation overview video of the ballpark groomer and renovator.



Accessories	Item Description	Part Number
	Mid Weight Bar 4500 Kit	70.4137

Product Description

The Ventrac DG550 ballpark renovator is designed solely for the purposes of renovating and maintaining ballpark infields. The DG550 includes features for weed management, edge line shaping, scarifying, and field leveling. When used with the three point hitch mounted Ventrac DR540 ballpark groomer, the Ventrac ballpark system can provide complete care for infield renovation, maintenance, and grooming.

The DG550 ballpark renovator can be used with any Ventrac 4000 series power unit.

Why Do I Need an Operator's Manual?

This manual has been created to help you gain the important knowledge of what is needed to safely operate, maintain, and service your machine. It is divided into sections for convenient reference of the appropriate section.

You must read and understand the operator's manual for each piece of Ventrac equipment you own. Reading the operator's manual will help you become familiar with each specific piece of equipment. Understanding the operator's manual will help you, as well as others, avoid personal injury and/or damage to the equipment. Keep this manual with the machine at all times. The manual should remain with the machine even if it is sold. If this manual becomes damaged or unreadable, it should be replaced immediately. Contact your local Ventrac dealer for a replacement.

When using a Ventrac attachment, be sure to read and follow the safety and operating instructions of both the power unit and the attachment being used to ensure the safest operation possible.

The information in this manual provides the operator with the safest procedures to operate the machine while getting the maximum use out of the unit. Failure to follow the safety precautions listed in this manual may result in personal injury and/or damage to the equipment.

INTRODUCTION

Using Your Manual

Throughout this manual, you will encounter special messages and symbols that identify potential safety concerns to help you as well as others avoid personal injury or damage to the equipment.

SYMBOL DEFINITIONS



ATTENTION

This symbol identifies potential health and safety hazards. It marks safety precautions. Your safety and the safety of others is involved.

There are three signal words that describe the level of safety concern: Danger, Warning, and Caution. Safety should always be the #1 priority when working on or operating equipment. Accidents are more likely to occur when proper operating procedures are not followed or inexperienced operators are involved.

Note: Right-Hand and Left-Hand orientations may be referred to at different places throughout this manual. Right-Hand and Left-Hand is determined as if sitting on the power unit seat facing forward.

SIGNAL WORD DEFINITIONS

⚠ DANGER

Indicates an imminently hazardous situation which, if not avoided, will result in death or serious injury. This signal word is limited to the most extreme cases.

⚠ WARNING

Indicates a potentially hazardous situation which, if not avoided, could result in death or serious injury.

⚠ CAUTION

Indicates a potentially hazardous situation which, if not avoided, may result in minor or moderate injury and/or property damage. It may also be used to alert against unsafe practices.

Manual Glossary

Power Unit A Ventrac tractor or other Ventrac engine powered device that may be operated by itself or with an attachment or accessory.

Attachment A piece of Ventrac equipment that requires a Power Unit for operation.

Accessory A device that attaches to a Power Unit or Attachment to extend its capabilities.

Machine Describes any "Attachment" or "Accessory" that is used in conjunction with a power unit.

SAFETY

Safety Decals

The following safety decals must be maintained on your DG550 ballpark renovator.

Keep all safety decals legible. Remove all grease, dirt, and debris from safety decals and instructional labels. If any decals are faded, illegible, or missing, contact your dealer promptly for replacements.

When new components are installed, be sure that current safety decals are affixed to the replacement components.

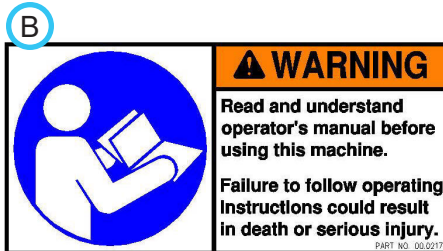
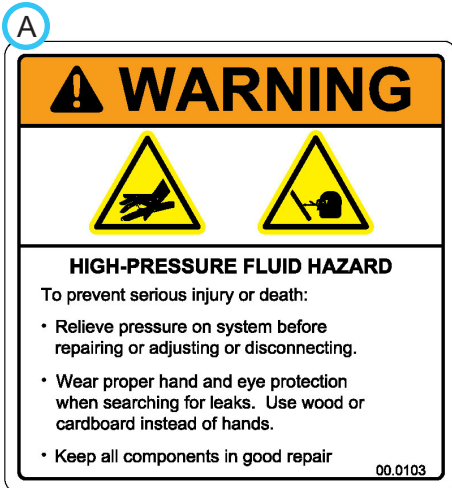
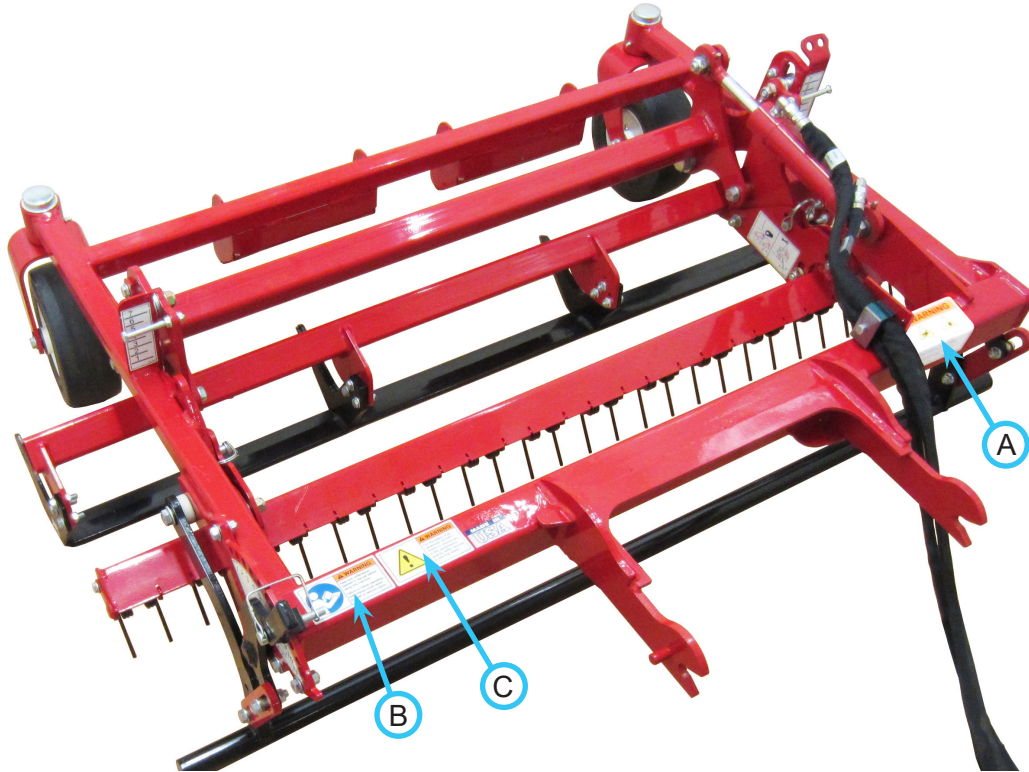

Decal	Description	Part Number	Quantity
A	Warning, High Pressure Fluid Hazard	00.0103	1
B	Warning, Read Owner's Manual	00.0217	1
C	Warning, General Safety	00.0220	1

SAFETY



General Safety Procedures for Ventrac Power Units, Attachments, & Accessories



Training Required

- The owner of this machine is solely responsible for properly training the operators.
- The owner/operator is solely responsible for the operation of this machine and prevention of accidents or injuries occurring to him/herself, other people, or property.
- Do not allow operation or service by children or untrained personnel. Local regulations may restrict the age of the operator.
- Before operating this machine, read the operator's manual and understand its contents.
- If the operator of the machine cannot understand this manual, then it is the responsibility of this machine's owner to fully explain the material within this manual to the operator.
- Learn and understand the use of all controls.
- Know how to stop the power unit and all attachments quickly in the event of an emergency.



Personal Protective Equipment Requirements

It is the responsibility of the owner to be sure that the operators use the proper personal protective equipment while operating the machine. Required personal protective equipment includes, but is not limited to, the following list.



- Wear a certified ear protection device to prevent loss of hearing.
- Prevent eye injury by wearing safety glasses while operating the machine.
- Closed toe shoes must be worn at all times.
- Long pants must be worn at all times.
- When operating in dusty conditions, it is recommended that a dust mask be worn.

Operation Safety

- Inspect machine before operation. Repair or replace any damaged, worn, or missing parts. Be sure guards and shields are in proper working condition and are secured in place. Make all necessary adjustments before operating machine.
- Some pictures in this manual may show shields or covers opened or removed in order to clearly illustrate any instructions. Under no circumstance should the machine be operated without these devices in place.
- Alterations or modifications to this machine can reduce safety and could cause damage to the machine. Do not alter safety devices or operate with shields or covers removed.
- Before each use, verify that all controls function properly and inspect all safety devices. Do not operate if controls or safety devices are not in proper working condition.
- Check parking brake function before operating. Repair or adjust parking brake if necessary.
- Observe and follow all safety decals.
- All controls are to be operated from the operator's station only.
- Always wear a seat belt if the machine has a roll cage/bar installed and in upright position.
- Ensure the attachment or accessory is locked or fastened securely to the power unit before operating.
- Ensure that all bystanders are clear of the power unit and attachment before operating. Stop machine if someone enters your work area.
- Always be alert to what is happening around you, but do not lose focus on the task you are performing. Always look in the direction the machine is moving.
- Look behind and down before backing up to be sure of a clear path.
- If you hit an object, stop and inspect the machine. Make all necessary repairs before operating machine again.
- Stop operation immediately at any sign of equipment failure. An unusual noise can be a warning of equipment failure or a sign that maintenance is required. Make all necessary repairs before operating machine again.

SAFETY



General Safety Procedures for Ventrac Power Units, Attachments, & Accessories



- If equipped with a high/low range feature, never shift between high and low range while on a slope. Always move the machine to level ground and engage the parking brake before shifting range.
- Do not leave machine unattended while it is running.
- Always park the machine on level ground.
- Always shut off engine when connecting attachment drive belt to the power unit.
- Never leave the operator's station without lowering the attachment to the ground, setting the parking brake, shutting off the engine, and removing the ignition key. Make sure all moving parts have come to a complete stop before dismounting.
- Never leave equipment unattended without lowering the attachment to the ground, setting the parking brake, shutting off the engine, and removing the ignition key.
- Only operate in well-lit conditions.
- Do not operate when there is a risk of lightning.
- Never direct the discharge of any attachment in the direction of people, buildings, animals, vehicles, or other objects of value.
- Never discharge material against a wall or obstruction. Material may ricochet back towards the operator.
- Use extra caution when approaching blind corners, shrubs, trees, or other objects that may obscure vision.
- Do not run the engine in a building without adequate ventilation.
- Do not touch the engine or the muffler while the engine is running or immediately after stopping the engine. These areas may be hot enough to cause a burn.
- Do not change the engine governor settings or over-speed the engine. Operating engine at excessive speed may increase the hazard of personal injury.
- To reduce the hazard of fire, keep the battery compartment, engine, and muffler areas free of grass, leaves, excessive grease, and other flammable materials.

Preventing Accidents



- Clear working area of objects that might be hit or thrown from machine.
 - Keep people and pets out of working area.
 - Know the work area well before operation. Do not operate where traction or stability is questionable.
 - Reduce speed when you are operating over rough ground.
 - Equipment can cause serious injury and/or death when improperly used. Before operating, know and understand the operation and safety of the power unit and the attachment being used.
- Do not operate machine if you are not in good physical and mental health, if you will be distracted by personal devices, or are under the influence of any substance which might impair decision, dexterity, or judgment.
 - Children are attracted to machine activity. Be aware of children and do not allow them in the working area. Turn off the machine if a child enters the work area.



Keep Riders Off

- Only allow the operator on the power unit. Keep riders off.
- Never allow riders on any attachment or accessory.

SAFETY



General Safety Procedures for Ventrac Power Units, Attachments, & Accessories



Operating On Slopes

- Slopes can cause loss-of-control and tip-over accidents, which can result in severe injury or death. Be familiar with the emergency parking brake, along with the power unit controls and their functions.
- If power unit is equipped with a fold down roll bar, it must be locked in the upright position when operating on any slope.
- Use low range (if equipped) when operating on slopes greater than 15 degrees.
- Do not stop or start suddenly when operating on slopes.
- Never shift between high and low range while on a slope. Always move the power unit to level ground and engage the parking brake before shifting range or placing the power unit in neutral.
- Variables such as wet surface and loose ground will reduce the degree of safety. Do not drive where machine could lose traction or tip over.
- Keep alert for hidden hazards in the terrain.
- Stay away from drop-offs, ditches, and embankments.
- Sharp turns should be avoided when operating on slopes.
- Pulling loads on hills decreases safety. It is the responsibility of the owner/operator to determine loads that can safely be controlled on slopes.
- Transport machine with attachment lowered or close to the ground to improve stability.
- While operating on slopes, drive in an up and down direction when possible. If turning is necessary while driving across slopes, reduce speed and turn slowly in the downhill direction.
- Assure a sufficient supply of fuel for continuous operation. A minimum of one-half tank of fuel is recommended.

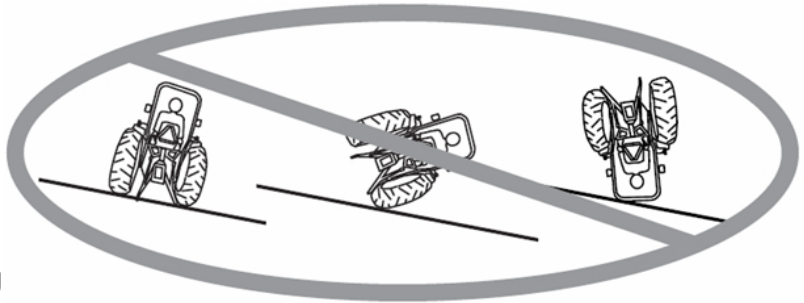

Roadway Safety

- Operate with safety lights when operating on or near roadways.
- Obey all state and local laws concerning operation on roadways.
- Slow down and be careful of traffic when operating near or crossing roadways. Stop before crossing roads or sidewalks. Use care when approaching areas or objects that may obscure vision.
- If there is doubt of safety conditions, discontinue machine operation until a time when operation can be performed safely.
- When operating near or on roadways, have a Slow Moving Vehicle Emblem clearly displayed.

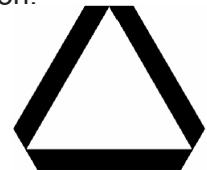

Truck Or Trailer Transport

- Use care when loading or unloading machine into a truck or trailer.
- Use full width ramps for loading machine into a truck or trailer.
- The parking brake is not sufficient to lock the machine during transport. Always secure the power unit and/or attachment to the transporting vehicle securely using straps, chains, cable, or ropes. Both front and rear straps should be directed down and outward from the machine.
- Shut off fuel supply to power unit during transport on truck or trailer.
- If equipped, turn the battery disconnect switch to the Off position to shut off electrical power.

SAFETY



General Safety Procedures for Ventrac Power Units, Attachments, & Accessories



Maintenance

- Keep all safety decals legible. Remove all grease dirt, and debris from safety decals and instructional labels.
- If any decals are faded, illegible, or missing, contact your dealer promptly for replacements.
- When new components are installed, be sure that current safety decals are affixed to the replacement components.
- If any component requires replacement, use only original Ventrac replacement parts.
- Always turn the battery disconnect to the Off position or disconnect the battery before performing any repairs. Disconnect the negative terminal first and the positive terminal last. Reconnect the positive terminal first and the negative terminal last.
- Keep all bolts, nuts, screws, and other fasteners properly tightened.
- Always lower the attachment to the ground, engage parking brake, shut off engine, and remove the ignition key. Make sure all moving parts have come to a complete stop before cleaning, inspection, adjusting or repairing.
- If the power unit, attachment, or accessory requires repairs or adjustments not instructed in the operator's manual, the power unit, attachment, or accessory must be taken to an authorized Ventrac dealer for service.
- Never perform maintenance on the power unit and/or attachment if someone is in the operator's station.
- Always use protective glasses when handling the battery.
- Check all fuel lines for tightness and wear on a regular basis. Tighten or repair them as needed.
- To reduce the hazard of fire, keep the battery compartment, engine, and muffler areas free of grass, leaves, and excessive grease.
- Do not touch the engine, the muffler, or other exhaust components while the engine is running or immediately after stopping the engine. These areas may be hot enough to cause a burn.
- Allow the engine to cool before storing and do not store near an open flame.
- Do not change the engine governor settings or over-speed the engine. Operating engine at excessive speed may increase the hazard of personal injury.
- Springs may contain stored energy. Use caution when disengaging or removing springs and/or spring loaded components.
- An obstruction or blockage in a drive system or moving/rotating parts may cause a buildup of stored energy. When the obstruction or blockage is removed, the drive system or moving/rotating parts may move suddenly. Do not attempt to remove an obstruction or blockage with your hands. Keep hands, feet, and clothing away from all power-driven parts.
- Dispose of all fluids in accordance with local laws.

Fuel Safety



- To avoid personal injury or property damage, use extreme care in handling gasoline. Gasoline is extremely flammable and the vapors are explosive.
- Do not refuel machine while smoking or at a location near flames or sparks.
- Always refuel the machine outdoors.
- Do not store machine or fuel container indoors where fumes or fuel can reach an open flame, spark, or pilot light.
- Only store fuel in an approved container. Keep out of reach of children.
- Never fill containers inside a vehicle or on a truck or trailer bed with a plastic liner. Always place containers on the ground away from your vehicle before filling.
- Remove machine from the truck or trailer and refuel it on the ground. If this is not possible, refuel the machine using a portable container, rather than from a fuel dispenser nozzle.
- Never remove fuel cap or add fuel with the engine running. Allow engine to cool before refueling.
- Never remove fuel cap while on a slope. Only remove when parked on a level surface.
- Replace all fuel tank and container caps securely.

SAFETY



General Safety Procedures for Ventrac Power Units, Attachments, & Accessories



Fuel Safety (continued)

- Do not overfill fuel tank. Only fill to bottom of fuel neck, do not fill fuel neck full. Overfilling of fuel tank could result in engine flooding, fuel leakage from the tank, and/or damage to the emissions control system.
- If fuel is spilled, do not attempt to start the engine. Move the power unit away from the fuel spill and avoid creating any source of ignition until fuel vapors have dissipated.
- If the fuel tank must be drained, it should be drained outdoors into an approved container.
- Dispose of all fluids in accordance with local laws.
- Check all fuel lines for tightness and wear on a regular basis. Tighten or repair them as needed.
- The fuel system is equipped with a shut-off valve. Shut off the fuel when transporting the machine to and from the job, when parking the machine indoors, or when servicing the fuel system.

Hydraulic Safety

- Make sure all hydraulic connections are tight and all hydraulic hoses and tubes are in good condition. Repair any leaks and replace any damaged or deteriorated hoses or tubes before starting the machine.
- Hydraulic leaks can occur under high pressure. Hydraulic leaks require special care and attention.
- Use a piece of cardboard and a magnifying glass to locate suspected hydraulic leaks.



- Keep body and hands away from pinhole leaks or nozzles that eject high pressure hydraulic fluid. Hydraulic fluid escaping under high pressure can penetrate the skin causing serious injury, leading to severe complications and/or secondary infections if left untreated. If hydraulic fluid is injected into the skin, seek immediate medical attention no matter how minor the injury appears.

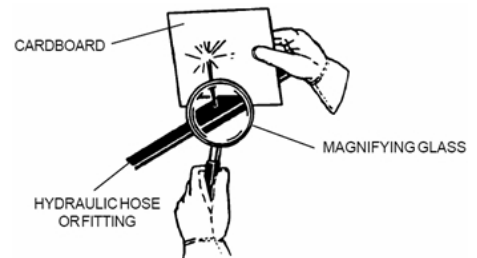

- Hydraulic system may contain stored energy. Before performing maintenance or repairs on the hydraulic system, remove attachments, engage parking brake, disengage weight transfer system (if equipped), shut off engine, and remove ignition key. To relieve pressure on the auxiliary hydraulic system, shut off the power unit engine and move the hydraulic control lever left and right before disconnecting the auxiliary hydraulic quick couplers.
- Dispose of all fluids in accordance with local laws.

SAFETY



DG550 Safety Procedures



- The ballpark renovator blades are very sharp. Wear gloves and use caution when installing, removing, adjusting, or handling the renovator blades.
- Attachment hydraulic system may contain stored energy. Before performing maintenance or repairs on the hydraulic system, the attachment's auxiliary hydraulic hoses must be disconnected from the power unit. Lower the attachment to the ground, shut off power unit engine, move the secondary S.D.L.A. lever left and right to relieve auxiliary hydraulic pressure, and disconnect the auxiliary hydraulic quick couplers.

OPERATIONAL CONTROLS

Renovator Blades



The renovator blades (A) are used to:

- Cut out weeds just below the surface for easy removal with a rake.
- Cut and maintain edge lines around the infield and warning track.
- Remove high spots and create a level profile under the surface.
- Create a loose surface to provide material for the leveling bars to distribute.
- Remove grooves left when the scarifier tines or spikes are used on a wet field.

The renovator blade depth is hydraulically controlled using the power unit's secondary SDLA lever*.

The renovator blades can be mounted in either the upper or lower set of holes. The lower set of holes provides 1-1/8" (28.5 mm) of ground clearance (fully raised) and 2-1/4" (57 mm) of cutting depth. The upper set of holes provides 1-3/4" (44.5 mm) of ground clearance (fully raised) and 1-5/8" (41 mm) of cutting depth.

Scarifier Spring Tines



The scarifier spring tines (B) are used to:

- Break up ground cut by the blades to help provide even material distribution to the leveling bars.
- Loosen and create more material flow to send to the leveling bars.
- Aid in adding surface mix or a drying agent to the field surface.

The scarifier spring tines are tied to the hydraulic adjustment for the renovator blades, but the tines can be adjusted in relation to the renovator blades.

Remove the pins (C) in the left and right scarifier adjustment plates to either rotate the scarifier spring

tines to the up position (tines do not contact the soil) or the down position (tines just above the renovator blades to break up material without leaving grooves).

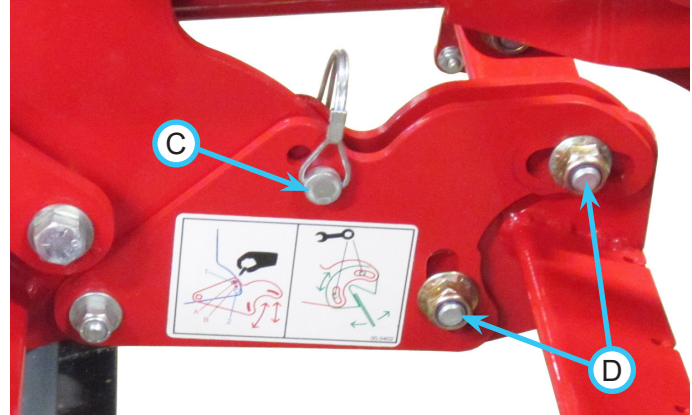

Loosening the bolts (D) that fasten the scarifier tine mount frame to the left and right scarifier adjustment plates allow the tine frame to be rotated to provide either more or less aggressive performance when the spring tines are in the down position.

Leveling Bar

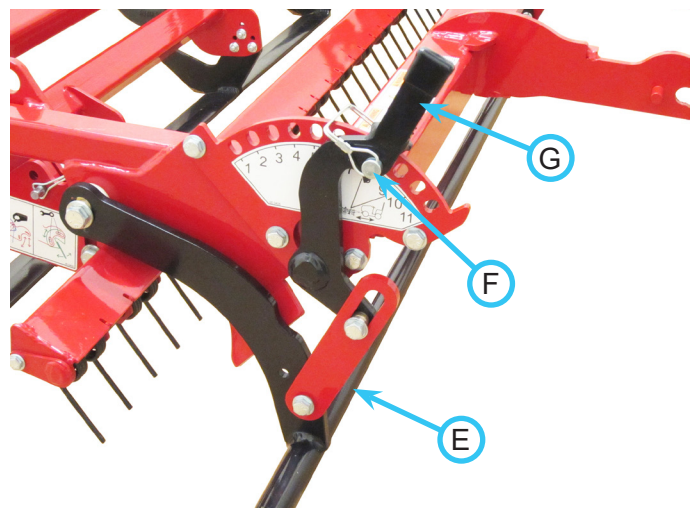

The leveling bar (E) is used to carry and distribute material to fill in low areas. The leveling bar can be allowed to float freely or can be set to a fixed height for more aggressive use.

Remove the locking pin (F) from the adjustment lever (G) to allow the leveling bar to float.

To set at a fixed height, move the lever to the desired position and insert the locking pin through the hole in the lever and the slot in the adjustment plate.

* Refer to power unit operator's manual for operation of power unit controls.

GENERAL OPERATION

Daily Inspection

⚠ WARNING

Always set the parking brake, shut off power unit engine, remove the ignition key, and ensure all moving parts have come to a complete stop before inspecting components, or attempting any repair or adjustment.

1. Park machine on a level surface, with the engine shut off and all fluids cold.
2. Perform a visual inspection of both the power unit and the ballpark renovator. Look for loose or missing hardware, damaged components, or signs of wear.
3. Inspect hydraulic hoses, hydraulic fittings, and fuel lines to ensure tight, leak free connections.
4. Refer to the power unit operator's manual. Check the power unit's engine oil, hydraulic oil, cooling system, tire pressure, and fuel level. Add fluid or service as required.
5. Test the power unit's operator safety interlock system*.

Attaching

1. Drive the power unit slowly forward into the hitch arms of the ballpark renovator. Align the lift arms of the power unit with the ballpark renovator hitch arms by raising or lowering the front hitch and complete the engagement.
2. Once completely engaged, close the front hitch locking lever.*
3. Engage the parking brake* and shut off the engine.
4. Wipe hose ends clean, and connect to the power unit's hydraulic quick couplers. If equipped, connect the hoses and quick couplers so the red indicators are paired together and the yellow indicators are paired together.

Detaching

1. Park the power unit on a level surface and set the parking brake.*
2. Lower the ballpark renovator to the ground.
3. Shut off power unit engine.
4. Lower the leveling bar to position 8 or 9 and secure with the pin.
5. Disconnect the hydraulic quick couplers from the power unit and store the hose ends in the frame holes on the ballpark renovator.
6. Disengage the front hitch locking lever.*

7. Restart power unit and slowly back away from the ballpark renovator. A side to side movement of the steering wheel may aid in disengagement.

Operating Procedures and Tips

Scan the QR code or visit <http://ventrac.com/QR/groomer> for an operation overview video of the ballpark groomer and renovator.



The renovator should be operated with the power unit's primary SDLA lever* in the float position. Shift the power unit into low range*.

Disengage the power unit's weight transfer system* (if equipped) during renovator operation, except when using the renovator blades for edging.

Check for base plugs and/or locating posts, water boxes, etc. under the field surface and mark the positions prior to using the renovator for edging, weed removal, or field leveling.

The following tables contain various field conditions along with general guidelines and tips for renovator and groomer use in each condition. For more detailed information and demonstrations, refer to the ballpark renovator and groomer operational video.

Procedure / Condition	
Wet Field - Ground is saturated	
DG550 Front Renovator	DR540 Rear Groomer
Engage scarifier tines if there is enough dry dirt available to incorporate into wet areas. If field is saturated, front renovator should be disengaged.	Roller is engaged with the 3-point hitch in the float position. Spike bar engaged. Leveling bar disengaged. Optional brush disengaged.

Use the spike bar to create more surface area on the field surface to accelerate drying times.

If only low spots contain moisture, the front scarifier tines and rear spikes will allow the operator to pull out wet material and incorporate dry material from around the wet area.

Allow the field to dry before finishing and preparing for game play.

After the field dries, the surface will likely have a crust and grooves that need to be removed. Set the renovator blades on the front renovator just below the surface to break up the crust and remove the grooves, before preparing field for use.

* Refer to power unit operator's manual for operation of power unit controls.

GENERAL OPERATION

Procedure / Condition	
Weed Management / Edge Line Shaping	
DG550 Front Renovator	DR540 Rear Groomer
Engage the renovator blades. Set blade depth below roots for edging and middle of the root for weed removal. Leveling bar disengaged. Scarifier tines disengaged.	Fully raised.

If necessary, add weights to the renovator to penetrate compacted ground.

Cutting large amounts of sod will tend to pull the unit to the side, making it difficult to maintain a straight line. It is better to make multiple passes, removing smaller portions at a time.

Add weights to the front renovator and engage the power unit's weight transfer (set to position # 2 or apply approximately half the weight transfer) to help maintain a straight line or follow the curve of the outfield grass.

To allow the renovator to get closer to the fence when edging or removing weeds from a warning track, remove the pins from the 3-point hitch arm sway bar links, push the rear groomer all the way to one side, and reinstall the pins in the sway bar links.

Remove cut sod and debris after finishing weed removal. Raking away weeds that have been cut out prior to finishing the field will result in a better finish.

Procedure / Condition	
Heavily Compacted Field - Dry, cracked, & very hard	
DG550 Front Renovator	DR540 Rear Groomer
Scarifier tines engaged if there are large brittle chunks that need to be broken up.	Roller is engaged with the 3-point hitch in the float position. Spike bar engaged. Leveling bar disengaged. Optional brush disengaged.

If necessary, add weights to the groomer to penetrate compacted ground.

Procedure / Condition	
Uneven Field / Low Spots	
DG550 Front Renovator	DR540 Rear Groomer
Renovator blades engaged and set approximately 1/4 inch (6.5 mm) deep. Scarifier tines placed just above the renovator blades to break up material. Leveling bar engaged and adjusted according to field conditions.	Roller is engaged with the 3-point hitch in the float position. Spike bar disengaged. Leveling bar engaged and adjusted according to field conditions. Optional brush disengaged.

Leveling is best accomplished in neutral conditions. If the field is wet, material will not elevate enough for the process to work. If the field is too dry, material will elevate, but will not settle enough to be effective. Working with a field that is neither saturated or dusty will yield the best results.

Add weights to the rear groomer as necessary to control packing and minimize surface ripples.

Level in straight lines making the longest passes possible. Do not make sharp turns with either the front renovator or the rear groomer engaged with the ground.

Use a slow, steady speed when moving large amounts of material.

When targeting a low spot, work the ground around and through it in all directions. Moving ground in all directions and constantly packing it on all sides will provide a longer lasting result than working from one direction only.

Field leveling is a process that will not be completed the first time. The field condition will gradually improve as the leveling process is repeated. If the field is allowed to sit without attention for prolonged periods, the field condition will regress back to much of its previous condition.

GENERAL OPERATION

Procedure / Condition	
Finish Grooming	
DG550 Front Renovator	DR540 Rear Groomer
Fully raised.	Roller is engaged with the 3-point hitch in the float position. Spike bar disengaged. Leveling bar engaged if desired. Optional brush engaged if not using drag mat. Drag engaged. Use steel drag in moderate moisture conditions and coco mat drag for dry conditions.

Finish grooming can be done in either high or low range. Do not operate at high speeds when turning in tight circles to prevent unintentional compaction and tire ruts.

Operating in circles with the drag mat will create a nice infield finish, while distributing material evenly. Change the way you finish the field so that you are not always working material the same direction (i.e. if you start at the pitcher's mound and work toward the outside every time, you will work more and more material to the edge and will require leveling more frequently).

SERVICE

⚠ WARNING

Always set the parking brake, shut off power unit engine, remove the ignition key, and ensure all moving parts have come to a complete stop before inspecting components or attempting any repair or adjustment.



Attention

If any component requires replacement, use only original Ventrac replacement parts.

Cleaning and General Maintenance

For best results, and to maintain the finish of the ballpark renovator, clean or wash the ballpark renovator to remove dust, dirt, and debris. Apply a thin layer of environmentally friendly vegetable or corn oil to the renovator blades to prevent rusting.

Tire Pressure

The ballpark renovator is equipped with flat-free, cushioning tires for maintenance free performance.

Scarifier Spring Tine Replacement

If a scarifier spring tine requires replacement:

1. Determine whether the spring tine is secured with the left or the right scarifier tine retainer shaft.
2. Remove the nut and bolt (A) securing the retainer shaft (B) to the scarifier tine mount.

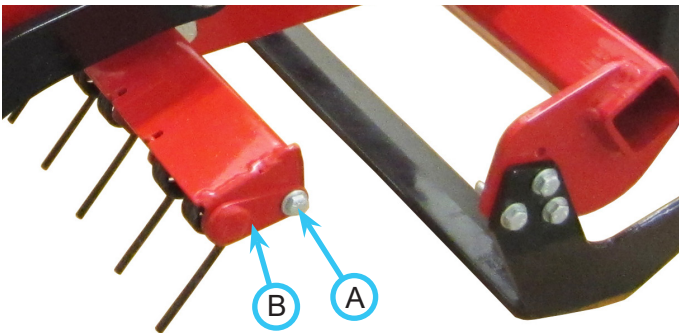

3. Slide the shaft out until you reach the scarifier spring tine that needs replaced.
4. Remove the old scarifier spring tine and position the new tine in place, matching the orientation of the other scarifier spring tines.
5. Slide the scarifier tine retainer shaft back into the scarifier tine mount, reinstalling the scarifier spring tines as you go.
6. Reinstall the nut and bolt to secure the scarifier tine retainer shaft to the scarifier tine mount and torque to 100 in-lbs (11 Nm).

Renovator Blade Replacement

⚠ CAUTION

Renovator blades are sharp. Wear gloves when working on or near the renovator blades.

If the cutting edge of a renovator blade becomes dull or damaged, it will need to be replaced.

1. Park the renovator and power unit on a level surface and lower the renovator to the ground.
2. Hydraulically raise the renovator blades to their highest position.
3. Engage the parking brake, shut off the power unit engine, and remove the key from the ignition.
4. Remove the three bolts that fasten each flange of the renovator blade to the blade mount frame.
5. Remove the old renovator blade and position the new renovator blade in place.
6. Reinstall the three bolts through each flange of the renovator blade, the flange of the adjacent renovator blade(s), and the blade mount frame. Secure with flange nuts and torque to 210 in-lbs (24 Nm).

Lubrication Locations

Lubrication is required at the following locations using a lithium complex NLGI #2 grease. Refer to the maintenance schedule for service intervals and amount of grease.

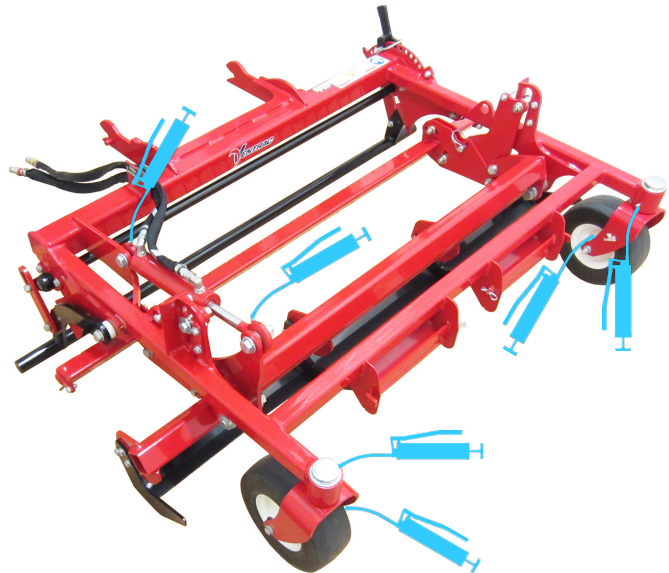

SERVICE

Storage

Preparing the Ballpark Renovator for Storage

1. Clean the ballpark renovator.
2. Inspect for loose or missing hardware, damaged components, or signs of wear. Repair or replace any damaged or worn components.
3. Inspect safety decals. Replace any safety decals that are faded, illegible, or missing.
4. Inspect hydraulic hoses and fittings to ensure tight, leak free connections. Repair or replace any damaged or worn components.
5. Apply grease to all grease points.
6. Wipe off all excess grease or oil.

Removing the Ballpark Renovator from Storage

1. Clean the ballpark renovator to remove any accumulated dust or debris.
2. Inspect the ballpark renovator as instructed in the daily inspection section of this manual.
3. Test the ballpark renovator to ensure all components are working properly.

SERVICE

Maintenance Schedule

Maintenance Schedule	# of Locations	# of Pumps	Daily	At 50 Hours	At 100 Hours	At 150 Hours	At 200 Hours	At 250 Hours	At 300 Hours	At 350 Hours	At 400 Hours	At 450 Hours	At 500 Hours	At 550 Hours	At 600 Hours	At 650 Hours	At 700 Hours	At 750 Hours	At 800 Hours	At 850 Hours	At 900 Hours	At 950 Hours	At 1000 Hours	Yearly
Caster Wheel Pivot	2	1	<input checked="" type="checkbox"/>	<input checked="" type="checkbox"/>	<input checked="" type="checkbox"/>	<input checked="" type="checkbox"/>	<input checked="" type="checkbox"/>	<input checked="" type="checkbox"/>	<input checked="" type="checkbox"/>	<input checked="" type="checkbox"/>	<input checked="" type="checkbox"/>	<input checked="" type="checkbox"/>	<input checked="" type="checkbox"/>	<input checked="" type="checkbox"/>	<input checked="" type="checkbox"/>	<input checked="" type="checkbox"/>	<input checked="" type="checkbox"/>	<input checked="" type="checkbox"/>	<input checked="" type="checkbox"/>	<input checked="" type="checkbox"/>	<input checked="" type="checkbox"/>	<input checked="" type="checkbox"/>	<input checked="" type="checkbox"/>	<input checked="" type="checkbox"/>
Wheel Axle Bearing	2	^	<input checked="" type="checkbox"/>	<input checked="" type="checkbox"/>	<input checked="" type="checkbox"/>	<input checked="" type="checkbox"/>	<input checked="" type="checkbox"/>	<input checked="" type="checkbox"/>	<input checked="" type="checkbox"/>	<input checked="" type="checkbox"/>	<input checked="" type="checkbox"/>	<input checked="" type="checkbox"/>	<input checked="" type="checkbox"/>	<input checked="" type="checkbox"/>	<input checked="" type="checkbox"/>	<input checked="" type="checkbox"/>	<input checked="" type="checkbox"/>	<input checked="" type="checkbox"/>	<input checked="" type="checkbox"/>	<input checked="" type="checkbox"/>	<input checked="" type="checkbox"/>	<input checked="" type="checkbox"/>	<input checked="" type="checkbox"/>	<input checked="" type="checkbox"/>
Cylinder Ends	2	^	<input checked="" type="checkbox"/>	<input checked="" type="checkbox"/>	<input checked="" type="checkbox"/>	<input checked="" type="checkbox"/>	<input checked="" type="checkbox"/>	<input checked="" type="checkbox"/>	<input checked="" type="checkbox"/>	<input checked="" type="checkbox"/>	<input checked="" type="checkbox"/>	<input checked="" type="checkbox"/>	<input checked="" type="checkbox"/>	<input checked="" type="checkbox"/>	<input checked="" type="checkbox"/>	<input checked="" type="checkbox"/>	<input checked="" type="checkbox"/>	<input checked="" type="checkbox"/>	<input checked="" type="checkbox"/>	<input checked="" type="checkbox"/>	<input checked="" type="checkbox"/>	<input checked="" type="checkbox"/>	<input checked="" type="checkbox"/>	<input checked="" type="checkbox"/>
Inspection																								
Inspect for Loose, Missing, or Worn Components.			<input checked="" type="checkbox"/>																					
Inspect for Bent or Broken Scarifier Spring Tines			<input checked="" type="checkbox"/>																					
Inspect Safety Decals			<input checked="" type="checkbox"/>																					

^Grease until fresh grease is visible.

Maintenance Checklist

Maintenance Checklist	# of Locations	# of Pumps	At 50 Hours	At 100 Hours	At 150 Hours	At 200 Hours	At 250 Hours	At 300 Hours	At 350 Hours	At 400 Hours	At 450 Hours	At 500 Hours	At 550 Hours	At 600 Hours	At 650 Hours	At 700 Hours	At 750 Hours	At 800 Hours	At 850 Hours	At 900 Hours	At 950 Hours	At 1000 Hours	Yearly	
																								Grease & Lubrication: See Lubrication Section
Caster Wheel Pivot	2	1																						
Wheel Axle Bearing	2	^																						
Cylinder Ends	2	^																						
Inspection																								
Inspect for Loose, Missing, or Worn Components.																								
Inspect for Bent or Broken Scarifier Spring Tines																								
Inspect Safety Decals																								

^Grease until fresh grease is visible.

SPECIFICATIONS

Dimensions

Overall Height	19 inches (48 cm)
Overall Length46 inches (117 cm)
Overall Width	56 inches (142 cm)
Weight	255 pounds (116 kg)
Renovator Blades	3) 18-1/2" (47 cm) wide blades
Cutting Depth Adjustment	Hydraulic
Cutting Depth (Maximum)	2-1/4 inches (5.7 cm)
Scarifier Spring Tines	28 Tines
Wheels.	9" flat free

Features

- Three renovator blades for weed removal, cutting and maintaining edge lines, and leveling.
- Scarifier tines for breaking up ground cut by the blades and adding surface mix or drying agent.
- Leveling bar carries and distributes material to fill in low areas.
- Cutting depth of blades is controlled with the power unit's auxiliary hydraulic handle.
- Can add up to six Ventrac weights to help penetrate compacted surfaces.

EC Declaration of Conformity

Ventrac DG550

Manufacturer	Venture Products, Inc. 500 Venture Drive Orrville, OH 44667 USA
Authorized Representative (also authorized to compile the technical file)	Lars Persson LAPAB MASKIN AB Box 46, S-734 22 Hallstahammar Flädervägen 5, 734 38 Hallstahammar SWEDEN
Technical File Keeper	Ryan Steiner Venture Products, Inc. 500 Venture Drive Orrville, OH 44667 USA
Description	Ballpark infield surface renovating attachment
Model Name	DG550 Ballpark Renovator
Model Number	39.55280
Serial Number	DG550-Axxxxxx
This Product Conforms to Directive	2006/42/EC
Ryan Steiner Director of Engineering 	24-July-2015 Orrville, Ohio USA

PARTS

ILLUSTRATED DRAWING Main Frame & Front Wheels

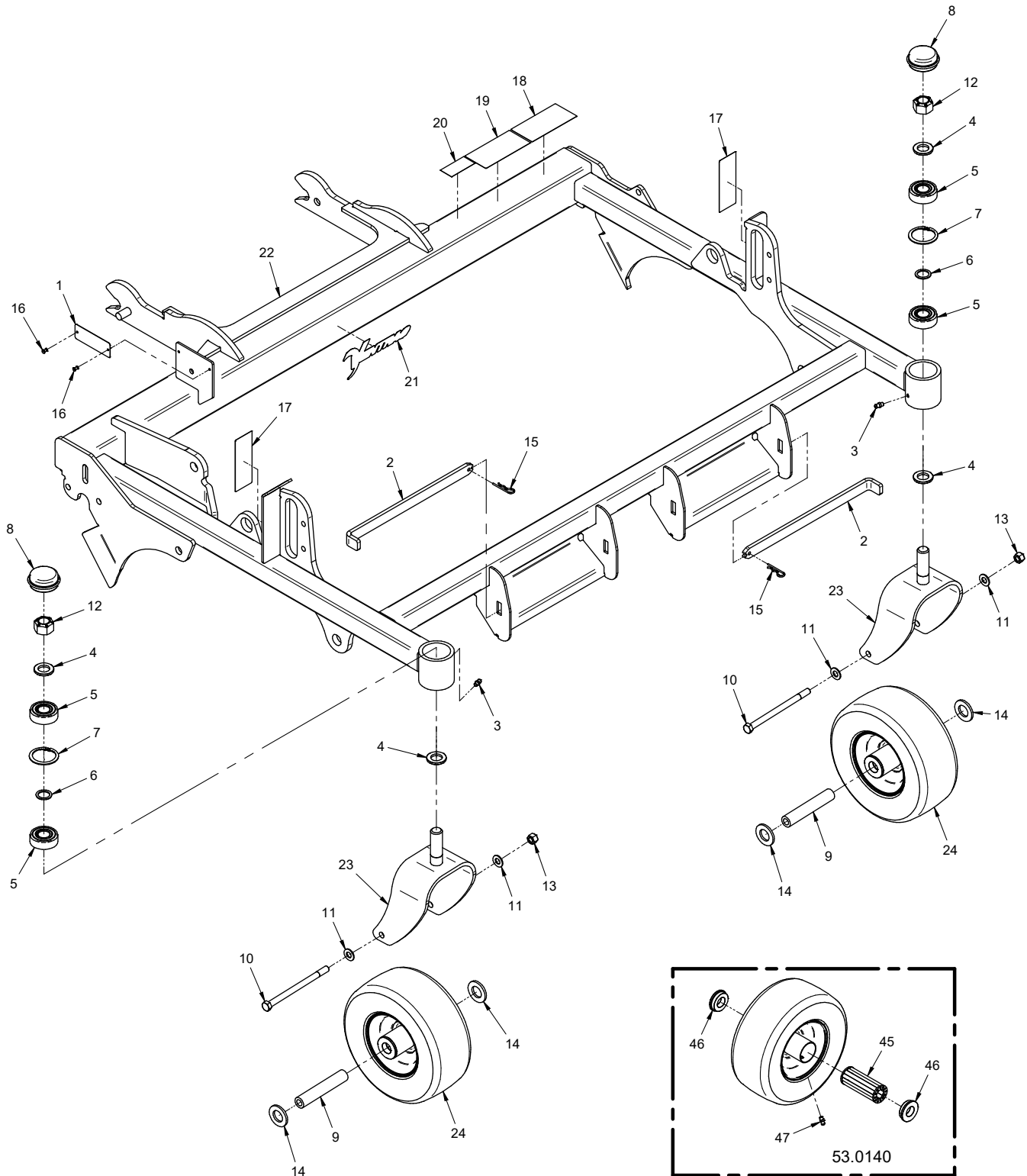

PARTS

Main Frame & Front Wheels

REF.	PART NO.	DESCRIPTION	QTY.
1	N/A	.PLATE, VENTRAC SERIAL NUMBER	1
2	64.1312	.PIN, WEIGHT RETAINER	2
3	29.GF0001	.GREASE FTG, 1/4 SAE ST	2
4	99.B0057-2	.WASHER, MACH 3/4 X 1-1/4 10 GA ZP	4
5	55.0023	.BEARING, BALL .75 ID X 1.78 OD	4
6	99.B0052	.SHIM, STEEL 3/4 X 1 X .062	2
7	04.0013	.SNAP RING, INT .062 X 1.75	2
8	53.0080	.DUST CAP, BEARING MOWER CASTER	2
9	50.0055	.TUBE, AXLE-WHEEL LM	2
10	90.0644	.BOLT, 3/8-16 USS X 5-1/2	2
11	95.06	.WASHER, FLAT 3/8 SAE	4
12	99.A12NF	.LOCKNUT, STOVER 3/4-16 SAE	2
13	99.A06N	.LOCKNUT, NYLON 3/8-16	2
14	95.12	.WASHER, FLAT 3/4 SAE	4
15	02.HP0313	.HAIRPIN, 3/32 X 1-5/8	2
16	04.0003	.RIVET, POP 1/8" X 3/8"	2
17	00.0401	.DECAL, CUTTING HEIGHT	2
18	00.0217	.DECAL, WARNING READ OWNERS MAN	1
19	00.0220	.DECAL, GENERAL SAFETY	1
20	00.0100	.DECAL, MADE IN USA	1
21	00.0382	.DECAL, VENTRAC	1
22	62.1442	.FRAME, CARRIER - DG550	1
23	50.0185	.SPINDLE, TIRE SWIVEL 9"	2
24	53.0140	.WHEEL, ASM 9 X 3.5 X4 FLATFREE	2
45	55.0071	.BEARING, ROLLER 3.25" LONG	1
46	55.0072	.BEARING, RETAINER 3/4"	2
47	29.GF0001	.GREASE FTG, 1/4 SAE ST	1

PARTS

ILLUSTRATED DRAWING Renovator Blades

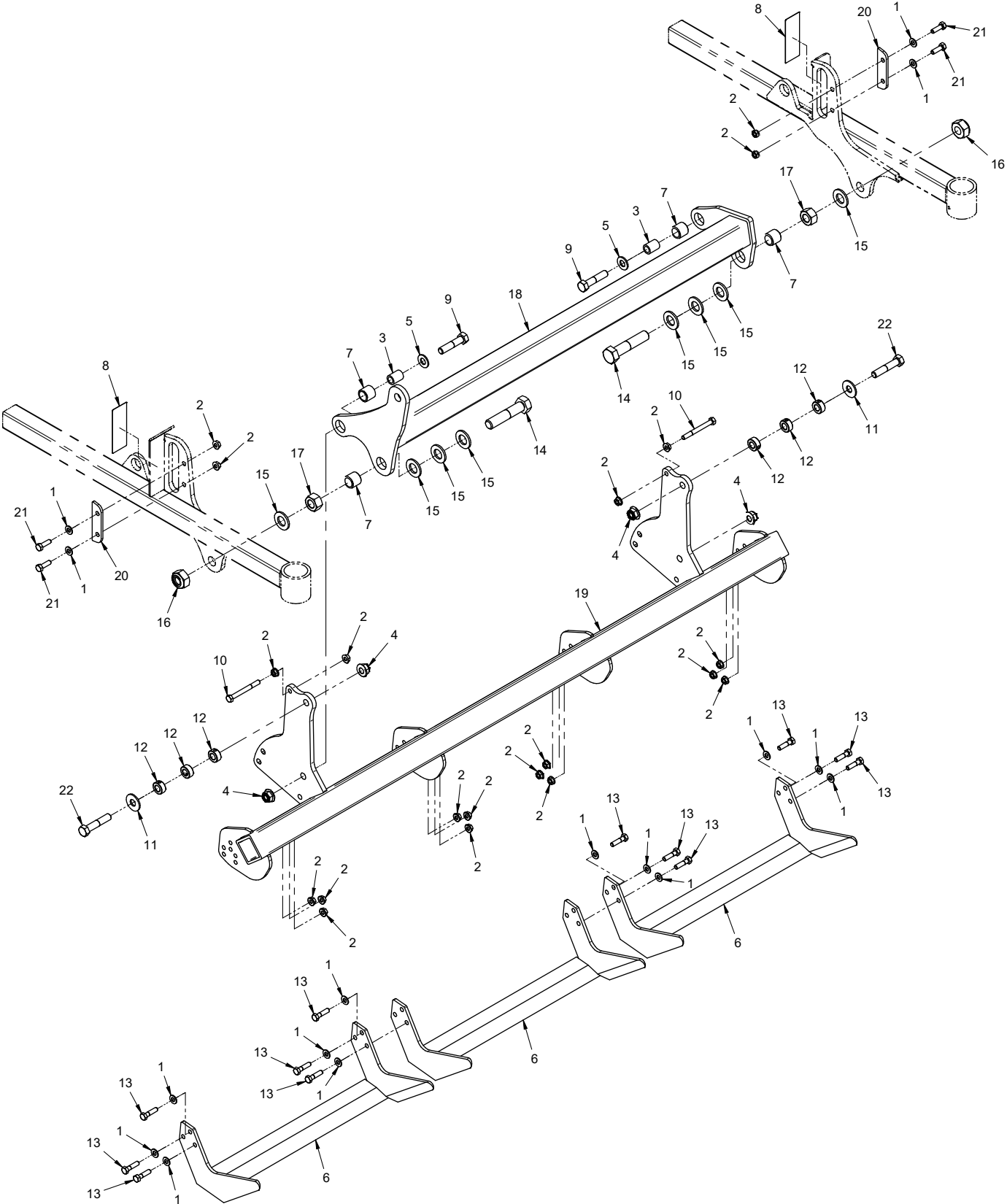

PARTS

Renovator Blades

REF.	PART NO.	DESCRIPTION	QTY.
1	95.05	WASHER, FLAT 5/16 SAE	16
2	99.SF05	NUT, SRF 5/16-18 USS	20
3	64.1889	BUSHING, PIVOT DG550	2
4	99.E0119	LOCKNUT, NYLON - FLANGE 1/2-13	4
5	95.08	WASHER, FLAT 1/2 SAE	2
6	79.0097	BLADE, CUTTING 18.50"	3
7	85.B0093	BUSHING, BRONZE SLEEVE	4
8	00.0401	DECAL, CUTTING HEIGHT	2
9	90.0818	BOLT, 1/2-13 USS X 2-1/4	2
10	90.0524	BOLT, 5/16-18 USS X 3"	2
11	94.08	WASHER, FLAT 1/2 USS	2
12	85.SC08	SET COLLAR, 1/2"	6
13	90.0510	BOLT, 5/16-18 USS X 1-1/4"	12
14	90.1228	BOLT, 3/4-10 USS X 3-1/2	2
15	95.12	WASHER, FLAT 3/4 SAE	8
16	99.E0115	NUT, JAM 3/4-10 NYLON LOCK WID	2
17	92.12	NUT, 3/4-10 USS	2
18	62.1444	FRAME, HEIGHT ADJUSTMENT PIVOT	1
19	62.1445	FRAME, CUTTER MOUNT	1
20	64.1884	PLATE, WEAR BAR	2
21	90.0508	BOLT, 5/16-18 USS X 1"	4
22	90.0820	BOLT, 1/2-13 USS X 2-1/2	2

PARTS

ILLUSTRATED DRAWING Hydraulic Height Adjust

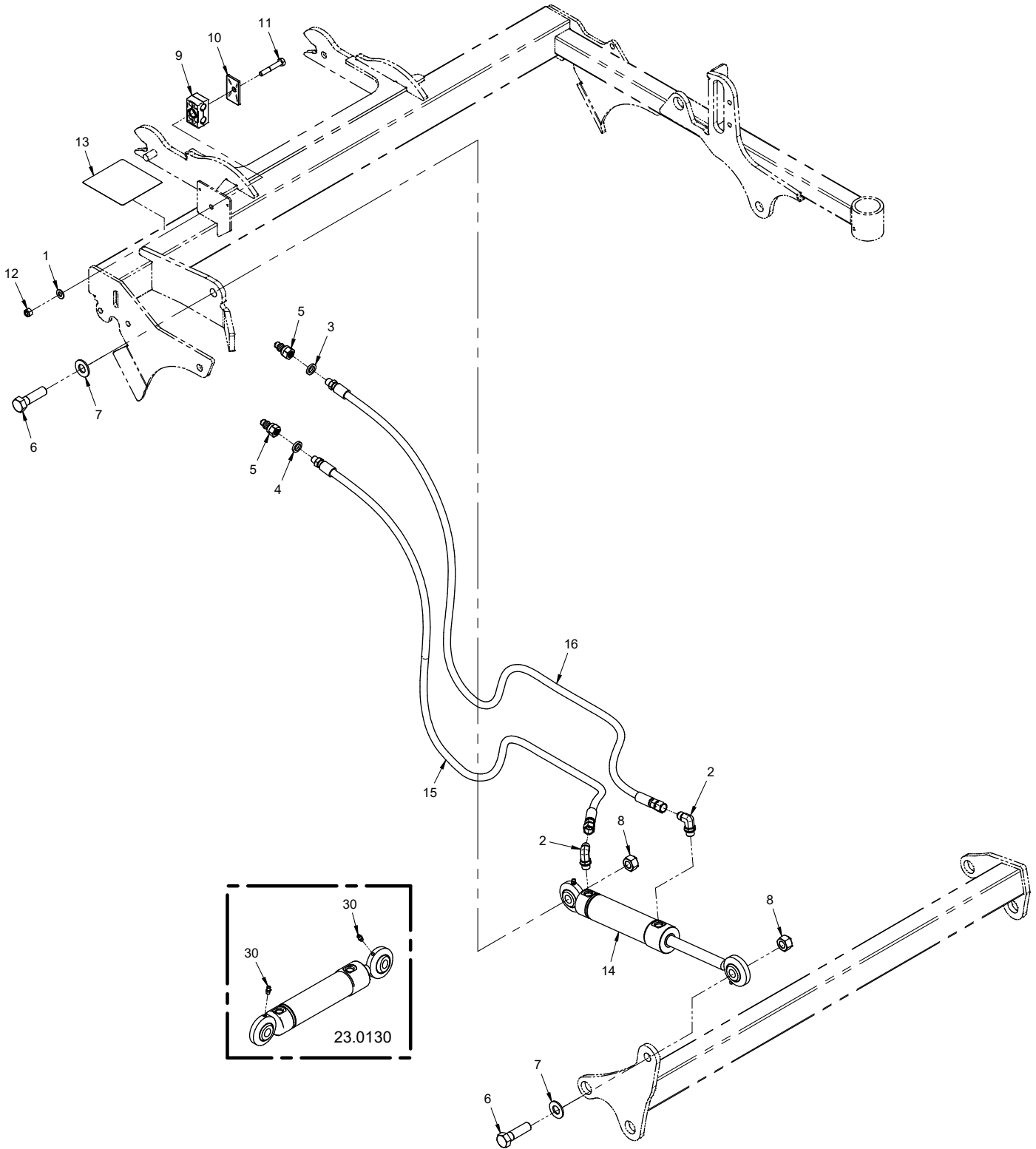

PARTS

Hydraulic Height Adjust

REF.	PART NO.	DESCRIPTION	QTY.
1	95.05	WASHER, FLAT 5/16 SAE	1
2	25.6801-06-06	FITTING, 90 ME 3/8 X 3/8	2
3	05.0117	WASHER, .544 ID X .817 X .14 YEL	1
4	05.0116	WASHER, .544 ID X .817 X .14 RED	1
5	23.0104	COUPLER, QUICK MALE 1/4	2
6	90.1018	BOLT, 5/8-11 USS X 2-1/4	2
7	95.10	WASHER, FLAT 5/8 SAE	2
8	99.A10	LOCKNUT, STOVER 5/8-11 USS	2
9	44.0256	CLAMP, HYD HOSE 12.7MM ID GRN	1
10	44.0229	COVER PLATE, 2D GROUP	1
11	90.0516	BOLT, 5/16-18 USS X 2"	1
12	99.A05N	LOCKNUT, NYLON 5/16-18 USS	1
13	00.0103	DECAL, HAZARD - HIGH PRESS. FLUID	1
14	23.0130	CYLINDER, 1-1/2" X 5"	1
15	20.0169	HOSE, 1/4X38.00 SAE 100R17 AR	1
16	20.0209	HOSE, 1/4X45.00 SAE 100R17 AR	1
30	29.GF0001	GREASE FTG, 1/4 SAE ST	2

PARTS

ILLUSTRATED DRAWING Scarifier Tines

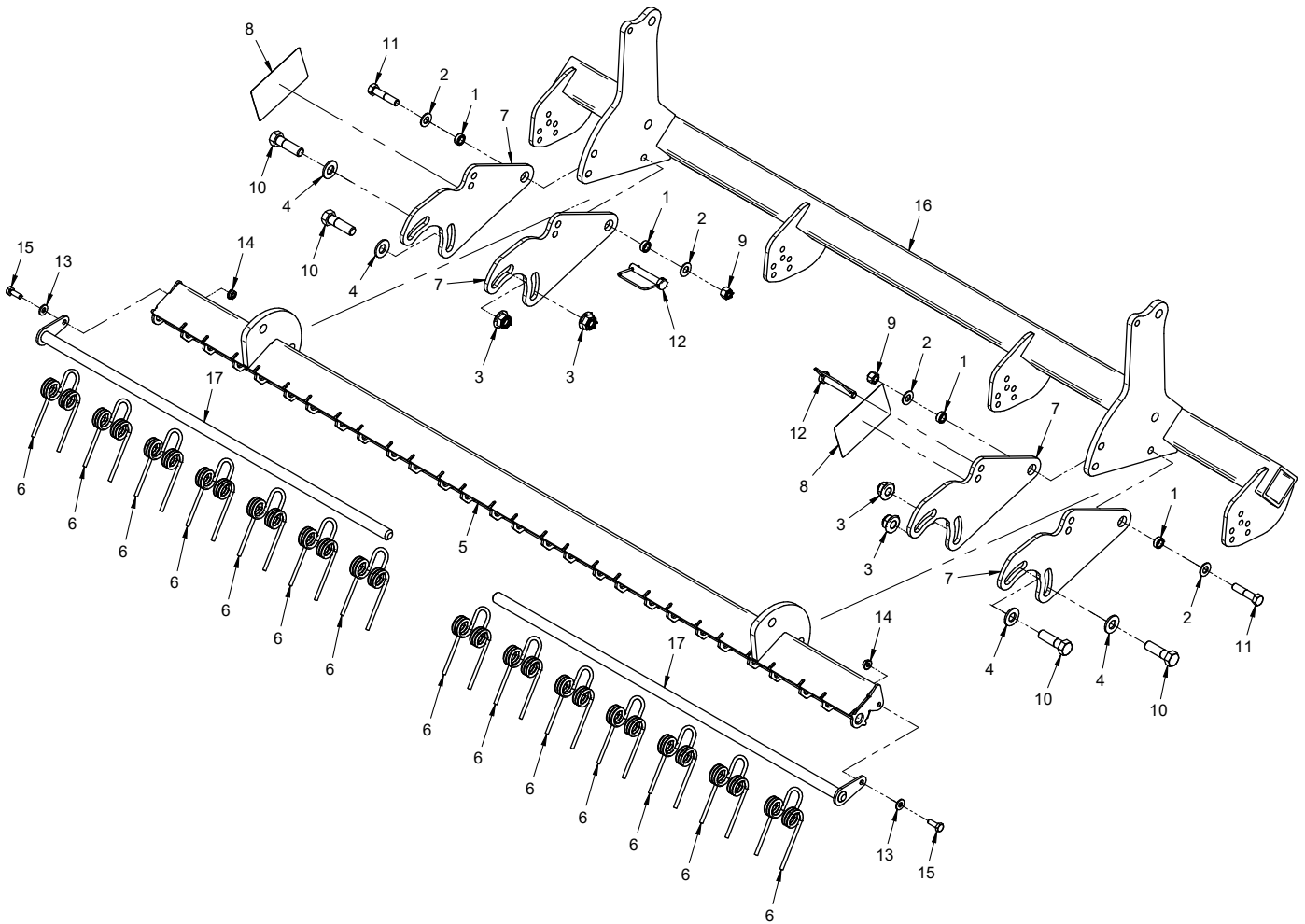

PARTS

Scarifier Tines

REF.	PART NO.	DESCRIPTION	QTY.
1	64.0602	.BUSHING, 3/8 X 5/8 X .265	4
2	95.06	.WASHER, FLAT 3/8 SAE	4
3	99.E0119	.LOCKNUT, NYLON - FLANGE 1/2-13	4
4	95.08	.WASHER, FLAT 1/2 SAE	4
5	62.1443	.FRAME, SCARIFIER TINE MOUNT	1
6	79.0101	.TINE, SCARIFIER SPRING	14
7	64.1887	.PLATE, SCARIFIER ADJUSTMENT	4
8	00.0402	.DECAL, SCARIFIER ADJUSTMENT	2
9	99.A06N	.LOCKNUT, NYLON 3/8-16 USS	2
10	90.0814	.BOLT, 1/2-13 USS X 1-3/4	4
11	90.0614	.BOLT, 3/8-16 USS X 1-3/4	2
12	03.0001	.PIN, SAFETY SNAP 3/8 X 1-3/4"	2
13	95.04	.WASHER, FLAT 1/4 SAE	2
14	99.SF04	.NUT, SRF 1/4-20 USS	2
15	90.0406	.BOLT, 1/4-20 USS X 3/4"	2
16	62.1445	.FRAME, CUTTER MOUNT	1
17	64.1888	.SHAFT, SCARIFIER TINE RETAINER	2

PARTS

Leveling Bar

REF.	PART NO.	DESCRIPTION	QTY.
1	64.1893	.PLATE, LEVELING BAR ADJUSTMENT	1
2	64.1886	.BRACKET, LEVEL SHAFT RETAINER	1
3	42.0577	.LINK, LEVELING BAR LIFT	2
4	64.0602	.BUSHING, 3/8 X 5/8 X .265	8
5	64.1889	.BUSHING, PIVOT DG550	2
6	00.0405	.DECAL, DRAG BAR HEIGHT ADJUST.	1
7	47.0377	.GRIP, HANDLE BLK FOAM 4-3/4 L	1
8	95.06	.WASHER, FLAT 3/8 SAE	10
9	99.SF06	.NUT, SRF 3/8-16 USS	10
10	90.0612	.BOLT, 3/8-16 USS X 1-1/2	4
11	90.0608	.BOLT, 3/8-16 USS X 1	6
12	99.E0119	.LOCKNUT, NYLON - FLANGE 1/2-13	2
13	90.0816	.BOLT, 1/2-13 USS X 2	2
14	95.08	.WASHER, FLAT 1/2 SAE	2
15	05.0159	.WASHER, NYLON .755IDX1.5ODX.5L	2
16	03.0003	.PIN, SAFETY SNAP 3/8 X 2-1/2"	1
17	62.1441	.SHAFT, LEVELING BAR ADJUSTMENT	1
18	62.1440	.FRAME, LEVELING BAR - DG550	1

PARTS

ILLUSTRATED DRAWING 70.4137 Mid Weight Bar 4500 Kit

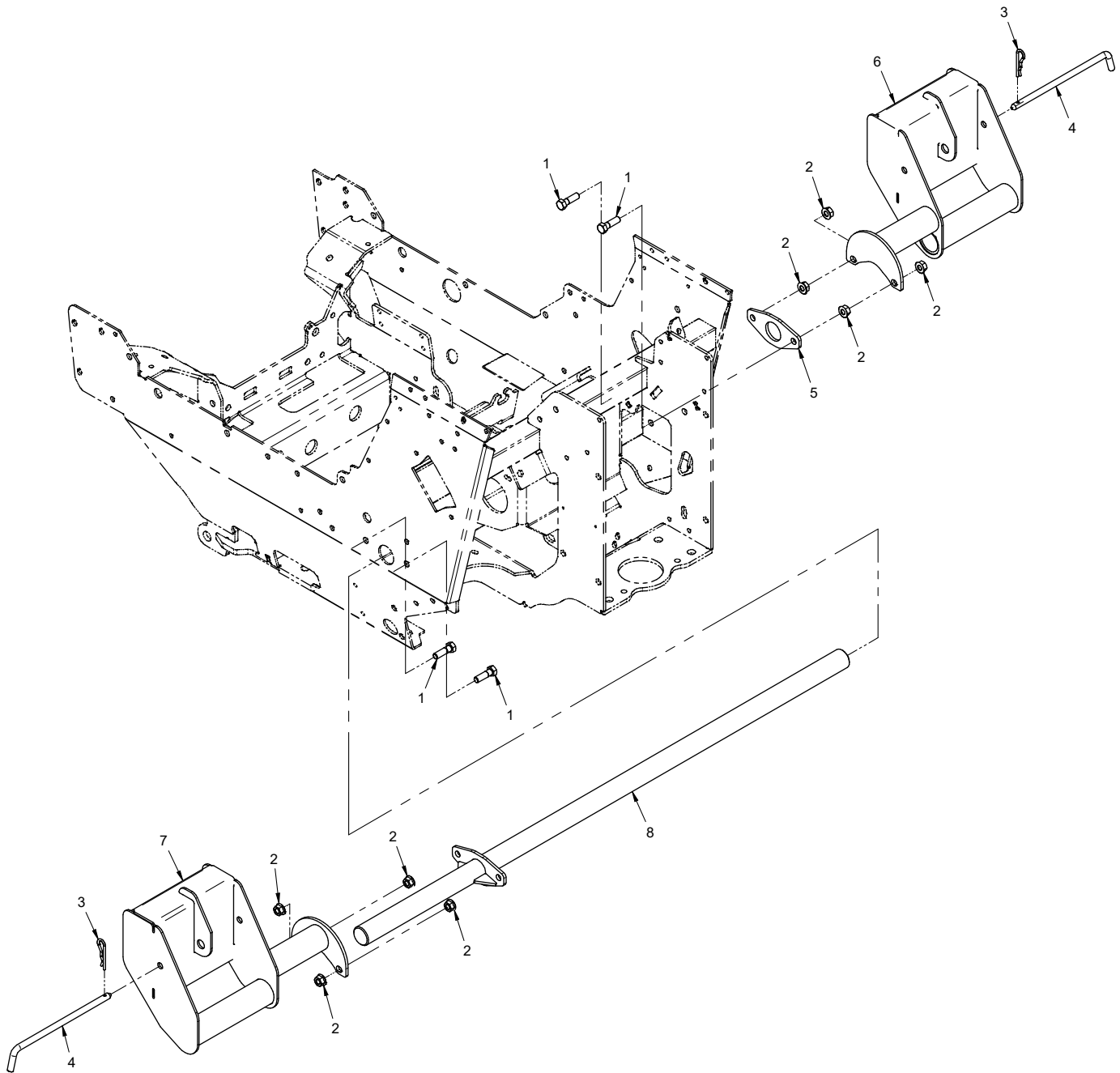

PARTS

70.4137 Mid Weight Bar 4500 Kit

REF.	PART NO.	DESCRIPTION	QTY.
1	90.0610	.BOLT, 3/8-16 USS X 1-1/4	4
2	99.SF06	.NUT, SRF 3/8-16 USS	8
3	02.HP0416	.HAIRPIN, 1/8 X 2	2
4	64.0761	.PIN, WEIGHT SECURE 7.3" USABLE	2
5	64.1029	.PLATE, REAR CLAMP CROSSBAR MT	1
6	62.1449	.FRAME, WEIGHT MID RIGHT	1
7	62.1448	.FRAME, WEIGHT MID LEFT	1
8	42.0455	.SHAFT, REAR ANCHOR MOUNT	1

WARRANTY



LIMITED WARRANTY - VENTRAC COMMERCIAL EQUIPMENT

Venture Products, Inc., (henceforth referred to as V.P.I.) warrants on the terms and conditions herein, that it will repair, replace, or adjust any part manufactured by Venture Products Inc., and found by Venture Products, Inc., to be defective in material and/or workmanship during the applicable warranty term.

All Ventrac commercial equipment purchased and registered on or after January 1, 2019 will carry a 2-year commercial warranty. The warranty period begins on the date of original customer purchase:

Ventrac Commercial Equipment	Warranty Term
2100 SSV & Attachments	2-year
3000 Series Tractors & Attachments	2-year
4000 Series Tractors & Attachments	2-year

All Ventrac add-on kits and accessories such as: 3-point hitch, 12V front & rear power outlets, foot pedal, dual wheel kit, etc., will be covered under the above warranty periods provided they are installed by an Authorized Ventrac Dealer. This warranty may be transferred and will carry the remainder of the warranty starting from the original purchase/registration date with the dealership and/or V.P.I.

The engine warranty is covered by its respective engine manufacturer. Please refer to the engine manufacturer's warranty statement that is included in the owner's manual.

For warranty consideration on Ventrac commercial equipment, including any defective part, must be returned to an Authorized Ventrac Dealer within the warranty period. The warranty shall extend to the cost to repair or replace (as determined by V.P.I.) the defective part. The expense of pickup and delivery of equipment, service call drive time or any transportation expense incurred for warranty repair is the sole responsibility of the owner and is not covered under warranty by Ventrac and/or V.P.I. Ventrac and V.P.I.'s responsibility in respect to claims is limited to making the required repairs or replacements, and no claim of breach of warranty shall be cause for cancellation or rescission of the contract of sale of any Ventrac equipment. Proof of purchase may be required by the dealer to substantiate any warranty claim. Only warranty work performed and submitted by an Authorized Ventrac Dealer may be eligible for warranty credit.

This warranty extends only to Ventrac commercial equipment operated under normal conditions and properly serviced and maintained. The warranty expressly does NOT cover: (a) any defects, damage or deterioration due to normal use, wear and tear, or exposure; (b) normal maintenance services, such as cleaning, lubrication, oil change; (c) replacement of service items, such as oil, lubricants, spark plugs, belts, rubber hoses, bearings or other items subject to normal service replacement; (d) damage or defects arising out of, or relating to abuse, misuse, neglect, alteration, negligence or accident; (e) repair or replacement arising from operation of, or use of the equipment which is not in accordance with operating instructions as specified in the operator's manual or other operational instructions provided by V.P.I.; (f) repair or replacement arising as a result of any operation from Ventrac equipment that has been altered or modified so as to, in the determination of V.P.I., adversely affect the operation, performance or durability of the equipment or that has altered, modified or affected the equipment so as to change the intended use of the product; (g) repair or replacement necessitated by the use of parts, accessories or supplies, including gasoline, oil or lubricants, incompatible with the equipment or other than as recommended in the operator's manual or other operational instructions provided by V.P.I.; (h) repairs or replacements resulting from parts or accessories which have adversely affected the operation, performance or durability of the equipment; or (i) damage or defects due to or arising out of repair of Ventrac equipment by person or persons other than an authorized Ventrac service dealer or the installation of parts other than genuine Ventrac parts or Ventrac recommended parts.

WARRANTY



LIMITED WARRANTY - VENTRAC COMMERCIAL EQUIPMENT

The sole liability of V.P.I. with respect to this warranty shall be the repair and replacement as set forth herein. V.P.I. shall have no liability for any other cost, loss, or damage. In particular V.P.I shall have no liability or responsibility for: (i) expenses relating to gasoline, oil, lubricants; (ii) loss, cost or expense relating to transportation or delivery of turf equipment from the location of owner or location where used by owner to or from any Authorized Ventrac Dealer; (iii) travel time, overtime, after hours' time or other extraordinary repair charges or charge relating to repairs or replacements outside of normal business hours at the place of business of an Authorized Ventrac Dealer; (iv) rental of like or similar replacement equipment during the period of any warranty repair or replacement work; (v) any telephone or telegram charges; (vi) loss or damage to person or property other than that covered by the terms of this warranty; (vii) any claims for lost revenue, lost profit or additional cost or expense incurred as a result of a claim of breach of warranty; or (viii) attorney's fees.

The remedies of buyer set forth herein are exclusive and are in lieu of all other remedies. The liability of V.P.I., whether in contract, tort, under any warranty, or otherwise, shall not extend beyond its obligation as set forth herein. V.P.I. shall not be liable for cost of removal or installation nor shall V.P.I. be responsible for any direct, indirect, special or consequential damages of any nature. In no event shall V.P.I. be liable for any sum in excess of the price received for the goods for which liability is claimed.

There are no representations or warranties which have been authorized to the buyer of the Ventrac commercial equipment other than set forth in this warranty. Any and all statements or representations made by any seller of this equipment, including those set forth in any sales literature or made orally by any sales representative, are superseded by the terms of this warranty. Any affirmation of fact or promise made by V.P.I. or any of its representatives to the buyer which relates to the goods that are the subject to this warranty shall not be regarded as part of the basis of the bargain and shall not be deemed to create any express warranty that such goods shall conform to the affirmation or promise.

No employee, distributor, or representative is authorized to change the foregoing warranties in any way or grant any other warranty on behalf of V.P.I.

Some states do not allow limitations on how long an implied warranty lasts or allow the exclusion on limitation of incidental or consequential damages, so the above limitation or exclusion may not apply to you.

This warranty gives you specific legal rights, and you may also have other rights which vary from state to state.

This warranty applies to all Ventrac commercial equipment sold by Venture Products Inc.